



Solar BOT Scope Book

REVISION RECORD			
Revision No.	Approval Date	Section / Page Revised	Reason / Description of Change
0	9/14/2023	All	<ul style="list-style-type: none"> • Original Publication
1	6/6/2024		<ul style="list-style-type: none"> • Added firebreak requirements • Added Fixed Tilt Racking, revised climatic conditions language • Revised risk section • Revised storm drainage requirements • Added class 8 truck requirements • Revised Fencing & Gates requirements, • Edits to Building on the Project Site, • Edits to Cable Management, • Edits to Grounding, • Edit to Lightning Protection, • Electrical Grounding will be captured in the design basis document • Edits to SCADA • Edits to Physical Security Installations, • Edit to Signage • Edit to Documentation to be Submitted at Substantial Completion Payment Date
25-1	7/28/2025	All	<ul style="list-style-type: none"> • Revised firebreak to not allow public roads • Editorial formatting throughout.
26-1	3/2/2026	All	<ul style="list-style-type: none"> • Reduced Wind Speed Risk Category to II • Editorial formatting throughout. • Added road inundation requirements to section 3.2.6 • Removed near access roads from bollard requirement in section 2.4.1
26-2	4/13/2026	All	<ul style="list-style-type: none"> • Reverted Wind Speed Risk Category to III for RFP submittal until change is approved

Solar BOT Scope Book Main Body

Solar BOT Scope Book

--	--	--	--

Solar BOT Scope Book

TABLE OF CONTENTS

1	General Data	7
1.1	Project Description	7
1.1.1	Access	8
1.2	Site Description	10
1.2.1	Climatic Conditions	10
1.3	Codes and Standards	10
1.4	Project Controls	12
1.5	Units and Language	12
1.5.1	Units for Calculations	12
2	Scope of Work	12
2.1	General	12
2.2	Design and Engineering	13
2.3	Property Protection	14
2.3.1	Risk Identification Process	14
2.3.2	Design Basis Document	15
2.4	Civil and Structural	15
2.4.1	Infrastructure and Outdoor Works	15
2.4.2	Electrical and I&C Systems	16
2.4.3	Storage	16
2.5	Mechanical	17
2.6	Electrical	17
2.6.1	PV System Circuits	17
2.6.2	Power Conversion System and PV Collection System	17
2.7	Environmental Requirements	17
2.8	Site Security – Construction	18
2.9	Temporary Site Installations and Laydown Areas (Including Buyer's Dedicated Office Trailer)	18
2.10	Tools, Spare Parts, and Consumables	19
3	Technical requirements	19
3.1	General System Requirements	19
3.2	Civil and Structural Requirements	19
3.2.1	General	19
3.2.2	Accessibility	20
3.2.3	Geotechnical Investigation	20
3.2.4	Site Clearing, Grading, Soil Improvement, and Revegetation	20
3.2.5	Construction Materials	21
3.2.6	Drainage and Stormwater Management	21
3.2.7	Erosion Control	22
3.2.8	Foundations	22
3.2.9	Corrosion Protection	23
3.2.10	Roads	24
3.2.11	Fencing and Gates	26
3.2.12	Parking and Access at the Project Site	27

Solar BOT Scope Book

3.2.13	Buildings on the Project Site	27
3.3	Electrical Requirements of the Project Site	28
3.3.1	General Requirements	28
3.3.2	Cables	28
3.3.3	Lighting	30
3.3.4	Grounding	31
3.3.5	Lightning Protection	32
3.3.6	Interconnection Requirements	32
3.4	Main Equipment Requirements	32
3.4.1	PV Modules	32
3.4.2	Single Axis Trackers	33
3.4.3	PCS	36
3.4.4	Auxiliary Equipment and Systems	37
3.4.5	SCADA	37
3.5	Control System and Communication Requirements	42
3.5.1	Control System Security	42
3.6	Met Station	43
3.7	Metering Requirements	44
3.8	Interconnection of Utilities	44
3.8.1	Data Network Engineering and Data Network Operations (DNE/DNO)	44
3.8.2	Desktop Equipment	45
3.9	Physical Security Installations	45
3.10	Locks	46
3.11	High Security Chain	47
3.12	Lock Forms	47
4	Energy Model and Energy Yield Verification	47
5	Commissioning and Testing	49
5.1	Commissioning Documentation and NERC Compliance	50
5.2	Factory Acceptance Tests	51
5.3	Project Performance Tests	52
5.3.1	PV Plant Capacity Test	52
5.3.2	PV Plant Availability Test	52
5.4	Equipment Warranties	52
6	Training	53
7	Health and safety requirements	54
7.1	General Requirements	54
7.1.1	Safety Rules and Procedures	55
7.2	Arc Flash Hazard Analysis Study and Calculation	55
7.3	Signage	55
8	Submittals	56
8.1	Documentation to be Submitted During Project Design (Documents IFC)	56
8.2	Documentation to be Submitted During Project Construction	59
8.3	Documentation to be Submitted at Substantial Completion Payment Date	60

Solar BOT Scope Book Main Body

Solar BOT Scope Book

8.4	Documentation to be Submitted after Substantial Completion Payment Date	61
-----	---	----

Solar BOT Scope Book

LIST OF APPENDICES

- Appendix 1: Collector Substation
- Appendix 2: High Voltage Overhead Transmission
- Appendix 3: Performance Guarantees
- Appendix 4: Energy Model
- Appendix 5: Design Basis and Operational Data
- Appendix 6: Key Equipment Datasheets
- Appendix 7: Project Performance Test Procedures
- Appendix 8: Project Site Map
- Appendix 9: Approved Vendors List
- Appendix 10: NERC Requirements
- Appendix 11: Project Controls
- Appendix 12: O&M Structure Requirements
- Appendix 13: Environmental Guidelines

Solar BOT Scope Book

1 General Data¹

This Appendix, including its attachments, is the Scope Book. This Scope Book is part of Acquisition Agreement between Seller and Buyer and subject to the rules of interpretation set forth therein. Terms with initial capital letters used but not defined in this Scope Book shall have the meanings ascribed to such terms in the Agreement unless the context otherwise requires. For the avoidance of doubt, the rules of interpretation set forth in the Main Body of the Agreement shall apply to this Scope Book.

This Scope Book describes certain requirements with respect to the Work. In performing the Work, Seller shall comply with the requirements specified in this Scope Book, all laws, and applicable permits.

This Scope Book provides the Minimum Functional Specification (**MFS**) for the Project, including scope and design requirements. In addition to the requirements set forth in the Agreement (including this Scope Book), all requirements specified in the Generator Interconnection Agreement (**GIA**) or any other Required Deliverability Arrangement shall be met.

This Scope Book includes elements that apply to the work contemplated by and the provisions set forth in Appendix 1- Collector Substation and Appendix 2- High Voltage Overhead Transmission Line. These elements include, among others, project controls; cybersecurity; environmental requirements; site fire protection; site security; temporary site installation and laydown areas; tools, spare part, and consumables; project utilities and redundancy; and control system and communication requirements.

1.1 Project Description

The Project will include the following main systems and equipment:

- Photovoltaic (**PV**) modules
- Trackers or Fixed Tilt Racking
- Direct Current (**DC**) collection system
- Inverters
- Foundations
- Meteorological (**met**) stations including all sensors, data collection, and Supervisory Control and Data Acquisition (**SCADA**)
- Transformers
- Switchgear
- Balance of System (**BOS**) and auxiliary equipment
- Backup power supply and emergency generator, if required for equipment protection or personnel safety (i.e., container and enclosure for Heating, Ventilation, and Air Conditioning (**HVAC**) and emergency lighting)
- Access and internal roads
- Water, fuel, power, and all other utilities

Seller shall provide all other ancillary equipment, systems, materials, and components necessary to deliver to Buyer a fully functional and operational Project. Among other things, the Project will be designed to comply with at least the following principles:

¹ NTD: The Scope Book remains subject in all respects to Buyer's continued due diligence and internal review (including by Buyer's subject matter experts). This draft may need to be revised to reflect certain matters included or not addressed in the Agreement or the request for proposal (RFP) or that have been reconsidered. Entergy reserves the right to issue an updated version of the Scope Book at a later date.

Solar BOT Scope Book

- Allow safe, reliable, and long-term operations.
- Provide maintenance access for all equipment (including Occupational Safety and Health Administration (**OSHA**) requirements).
- Achieve at least a 30-year life for structural components.
- Minimize operator surveillance intending the Project be designed to operate autonomously with minimal interaction by operators so limited Operations and Maintenance (**O&M**) staff is required.
- Provide reliable power to the interconnected electric grid.
- Minimize adverse local community impacts.
- Minimize impact of fire and natural hazards on site.

1.1.1 Access

1.1.1.1 General Spacing Requirements

Table 1 and correlating Figure 1 are to indicate spacing requirements within the site for various pieces of equipment, roads, and fencing.

Table 1: Row spacing and clearance requirements

Code	Description	Dimension	Comment
A	Edge of Module to E/W fence	25 ft	Maintain appropriate distance for access/maintenance.
B	N/S edge to N/S fence	25 ft	Maintain appropriate distance for access/maintenance.
C	Edge to edge spacing	10 ft	Spacing between module edges for maintenance access – when modules are in horizontal position.
D	N/S edge to N/S edge	15 ft	Vehicle access requirements must be considered.
E	Drive pile to road	7 ½ ft	To row end pile and edge of modules (when horizontal).
F	Fence to property line	5 ft	Or otherwise mandated by the local jurisdiction.

Solar BOT Scope Book

Figure 1: Clearances required for solar project construction

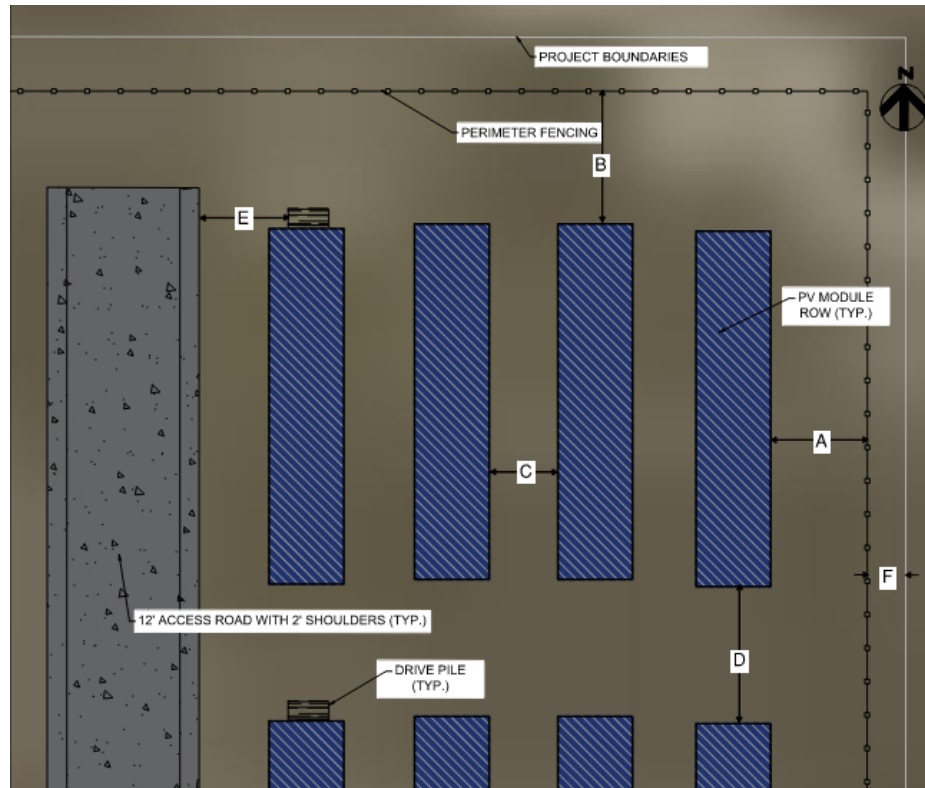

1.1.1.2 Site Perimeter Fire Break

A minimum 10-foot-wide, continuous, noncombustible fire break surface shall be provided at the site boundary. A minimum 9-foot clear space for vegetation management shall be maintained between the array and the fire break. The width of the fire break and vegetation management area are included in Code A or B of Figure 1 and Table 1 above.

In general, the fire break shall consist of a gravel surface at least 4-inch depth with woven geofabric base provided between the modules and perimeter fencing.

Terrain slope perpendicular the credited fire break shall be less than 10% within 50-feet of the noncombustible surface edge.

Based on the specific site conditions, Seller may propose an alternate fire break to Buyer for approval. The alternate fire break must meet all the following conditions and be approved by the Buyer prior to installation:

- The perimeter fire break must be a continuous noncombustible surface.
- The credited property shall be under control of the Project.

1.1.1.3 Access Gates

One motor operated sliding gate is required at every entrance to any fenced section of the PV Yard which contains, either on a DC or AC ratio, greater than or equal to 30% of the total site's respective DC or AC. One non-motor operated sliding gate which can be easily converted to a motor operated sliding gate is

Solar BOT Scope Book

required at every entrance to any fenced section of the PV Yard which contains, either on a DC or AC ratio, less than 30% and greater than or equal to 15% of the total site's respective DC or AC. Either sliding gates or swing style gates shall be used to access all other areas of the PV yard (i.e., those which contain, either on a DC or AC ratio, less than 15% of the total site's respective DC or AC.) Refer to section 3.9 for keypad access details and section 3.2.11 for fencing and gate requirements.

1.2 Site Description

1.2.1 Climatic Conditions

The Project shall be designed considering the climatic conditions set forth in Appendix 5 and any other climatic or environmental conditions that would be expected to be encountered or occur at the Project Site during the expected Project life. The Project equipment, materials, and components incorporated into the Project shall be suitable and rated for such climatic conditions. The Project shall be capable of sustaining minimal damage and operating properly at such conditions.

The site shall be designed in accordance with the following:

- Minimum Design Temperature is the lowest 0.2% percentile of the hourly temperatures measured in the months of December, January, and February from 01/01/2000 through the date the measurement is calculated. The hourly data set shall be mutually agreed upon but is expected to come from sources such as the National Weather Service/National Oceanic and Atmospheric Administration and is expected to be the closest available reporting station to the project site.
- Maximum Design Operating Temperature is the greater of 104°F (40°C) OR 0.4% Cooling Dry Bulb temperature as determined by the latest ASHRAE dataset using the closest reporting station to the project site.
- Maximum Design Analyzed Temperature is the 50-year Maximum Extreme Annual Dry Bulb temperature as determined by the latest ASHRAE dataset using the closest reporting station to the project site.
- The site shall be designed to operate at full contractual capacity from the Minimum Design Temperature to the Maximum Design Operating Temperature.
- The site is allowed to derate at no more than 10% nameplate power / 39°F (1°C) from Maximum Design Operating Temperature to Maximum Design Analyzed Temperature.
- The site shall be designed and analyzed to operate between the Minimum Design Temperature and the Maximum Design Analyzed Temperature without causing any short- or long-term damage to any equipment.

Performance modeling for the Project shall utilize a bankable weather data file such as Solar GIS, 3Tier, or Clean Power Research. This data shall be included as Appendix 4, which is based on the solar resource assessment report provided to Buyer by Seller.

Design wind speed for the Project and all components shall be per American Society of Civil Engineers (ASCE) 7, Risk Category III.

1.3 Codes and Standards

Seller shall design, procure, construct, commission, and test the Project, including all equipment, materials, components, and auxiliary facilities and systems, in accordance with the most recently established codes and standards, or the code agreed upon at the time of the agreement.

Seller shall perform the Work and otherwise cause the Project to comply with the applicable standards set forth in Table 2 below.

Seller shall design the Project in accordance with all applicable federal, state, and local laws and codes, regulations and standards provided by the organizations listed below. Where these codes do not govern

Solar BOT Scope Book

specific features of the equipment or system, Seller, and Original Equipment Manufacturer (**OEM**) standards shall be applied. Where local codes or ordinances will have an impact on the design (e.g., building height restrictions) or equipment selection, Seller shall jointly address these with the local Authorities Having Jurisdiction (**AHJ**). Seller shall review all applicable laws, codes, and standards throughout the project duration. Any change in requirements which become applicable to the Work prior to final turnover shall be identified and presented to Buyer with recommended implementation options for Buyer’s consideration and final approval.

Table 2: Applicable Standards and Organizations

Applicable Standards and Organizations	
AASHTO	American Association of State Highway and Transportation Officials
ACI	American Concrete Institute
AISC	American Institute of Steel Construction
AISI	American Iron and Steel Institute
ANSI	American National Standards Institute
ASCE	American Society of Civil Engineers
ASHRAE	American Society of Heating Refrigerating and Air Conditioning Engineers
ASME	American Society of Mechanical Engineers
ASTM	American Society for Testing Materials
AWS	American Welding Society
IBC	International Building Code
ICE	Institution of Civil Engineers
ICEA	Insulated Cable Engineers Association
IEC	International Electrotechnical Commission
IEEE	Institute of Electrical and Electronics Engineers
IESNA	Illuminating Engineering Society of North America
ISO	International Standardization Organization
NEC	National Electrical Code
NEMA	National Electrical Manufacturers Association
NERC	North America Electric Reliability Corporation
NESC	National Electrical Safety Code
NFPA	National Fire Protection Association
OSHA	Occupational Health & Safety Administration
SSPC	Steel Structures Painting Council
UL	Underwriters Laboratories

Solar BOT Scope Book

1.4 Project Controls

Refer to Appendix 11 for requirements related to Project Controls.

1.5 Units and Language

1.5.1 Units for Calculations

Unless otherwise indicated, English units will be used in all calculations, as specified in Table 3 below.

Table 3: Units for Calculations

Measurement	Units
Area	Acre
Dimensions	Feet (Ft) or Mile (Mi)
Electrical Energy	Kilowatt per hour (kWh) or megawatt per hour (MWh)
Electrical Power	Kilowatt (kW) or megawatt (MW)
Mass	Pound (lb) or ton
Temperature	Fahrenheit (°F)
Velocity	Miles per hour (mph)
Voltage	Volt (V) or kilovolt (kV)
Volume	Feet cubed (ft ³)

2 Scope of Work

2.1 General

The Work shall include:

- Survey and assessment of the Project Site
- Development, design, engineering, permitting, procurement, manufacturing, and Factory Acceptance Testing (**FAT**) of major engineered equipment
- Equipment and materials delivery, unloading, handling, and storage at the Project Site
- Erection, construction, equipment and system integration, onsite Quality Assurance / Quality Control (**QA/QC**), commissioning, and testing of the Project
- Onsite QC system, description, and execution program
- Works and services related to preparation, civil, mechanical, electrical, Instrumentation and Control (**I&C**), and communication
- Security of Project Site
- Utilities and interconnections needed for construction, commissioning, and testing such as potable and non-potable water, temporary power, telecommunications and internet, and fuel
- Site specific safety plan and implementation
- Project hand-off and training
- Environmental compliance and implementation
- Site restoration as required

Solar BOT Scope Book

2.2 Design and Engineering

Seller shall be responsible for all design and engineering of the Project and Project Site in accordance with this Scope Book. Seller shall perform all design and engineering Work in accordance with all Laws (including codes and standards) and applicable permits. The design shall meet the interface requirements of the [Entity] Transmission System, and the Independent System Operator (**ISO**) if applicable, including communications and battery limits.

The energy and other products delivered to the grid shall comply with the requirements of the GIA.

All equipment incorporated into the Project or otherwise sold to Buyer under the Agreement shall be of proven design for the intended use of such equipment.

The Project shall include a well-established classification and identification “tagging” system consistently in all phases of the Project. Seller shall obtain Buyer approval prior to implementation of the tagging system.

Appendix 9 sets forth the list of approved vendors for the equipment specified therein. Seller may only procure equipment specified in Appendix 9 from an approved vendor. Alternative vendors must be approved in writing by Buyer.

Seller shall provide documentation as further detailed in Section 8.1 of this Scope Book to Buyer for Buyer’s design review of the Project at the following milestones:

- 30% detailed design completion
- 60% detailed design completion
- 90% detailed design completion
- 100% detailed design completion prior to issuance for construction
- As-built drawings after project completion

Seller may deliver documents for a given system as it reaches a design milestone instead of delivering all documents in a single package. Buyer shall have 10-business days to review and provide comments to each set of design documents provided by Seller. Seller shall consider in good faith comments from Buyer on each set of documents and any subsequent input from Buyer regarding such comments or Seller’s response thereto.

For Buyer comments provided to Seller following delivery of the proposed Issued For Construction (**IFC**) design documents, Seller shall promptly notify Buyer in writing of, document (for Buyer’s review), and describe any changes made thereto, as a result of Buyer’s comments or otherwise, and provide Buyer no less than five business days to review and comment on the modified design documents. This process shall continue until Seller proposes no additional changes to Buyer or Buyer provides no additional comments to Seller. Buyer and seller shall follow RFI procedure and guidelines to achieve change management completion and acceptance.

The preliminary Project Site layout in Appendix 8 sets forth the preliminary layout of the Project, including certain Project design parameters:

- Ground cover ratio as used in the performance guarantee
- Selected Direct Current: Alternating Current (**DC:AC**) ratio as used in the performance guarantee
- Major equipment used (solar module, tracker/racking, Power Conversion System (**PCS**))
- Electrical interconnection facilities voltage and substation location
- Access road specifications, including width, internal turning radii, and surfacing cross section
- Flood inundation analysis
- Project Site ingress and egress
- Confirmation of temperature-corrected maximum voltage calculation (1,500 Vdc)
- Project generation tie lines and the electrical interconnection point in accordance with the GIA.

Solar BOT Scope Book Main Body

Solar BOT Scope Book

The detailed design of the Project shall be finalized in accordance with the Project Schedule.

2.3 Property Protection

2.3.1 Risk Identification Process

2.3.1.1 General Inputs

Seller shall design and build the project to meet all laws, codes, and practices applicable to life preservation, property preservation, and limiting liability to the public. Seller shall conduct studies and necessary evaluations to support any proposed deviation from requirements or industry standards.

The property protection methodology places emphasis on passive design that requires little to no external actions. Material selection, design considerations, and site layout should prevent a single event from propagating damages to the extent possible.

The standards shall be utilized as applicable for the design basis considerations:

- International Building code (**IBC**) of the edition adopted by the state and local jurisdiction.
- International Fire code (**IFC**) of the edition adopted by the state and local jurisdiction.
- NFPA 850 “Recommended Practice for Fire Protection for Electric Generating Plants and High Voltage Direct Current Converter Stations”, (Performance-Based Criteria in Chapter 4)
- ASTM E2908-12 “Standard Guide for Fire Prevention for Photovoltaic Panels, Modules, and Systems”
- National Wildfire Coordinating Group (**NWCG**), PMS 437-1 “NWCG Guide to Fire Behavior Assessment”
- Best Practices: EEI, EPRI, IEEE
- NFPA Fire Protection Handbook

2.3.1.2 Project Specific requirements

The project-specific design process shall include but not limited to the following considerations:

- Assumed onsite staffing levels for operation
- An all-weather fire break that parallels the entire perimeter fence shall be designed and kept clear of vegetation suitable for a fire break.
- Prior to Substantial Completion, Seller to maintain site vegetation in accordance with ASTM E-2908-12 section 8.5.5 or equivalent standard considering dormant 1 hour fuels with 20 percent or less fuel moisture content as described in PMS 437-1 “NWCG Guide to Fire Behavior Assessment”
- Discussion of plant layout and geographic location in relation to natural or manmade hazards that could physically impact operation or damage onsite property
- Equipment design and redundancy when credited to actively mitigate damage. (E.g. automatic stow features, emergency equipment isolations)
- Proximity fire services and suitable water supply as agreed by local AHJ
- Proximity of medical emergency services responding to the site
- Fences shall discourage trespass or inadvertent human access to the facility. Perimeter fence postings interval shall be legible from all perimeter vantage points.
- Publicly recognized discrete physical address at each point of entry with normal and emergency contacts posted on the gate.
- Methodology of providing prompt emergency responder access to the facility from Buyers remote and continually staffed operations center.
- Historical geographic loss information / industry operational experience
- Use of structure / equipment smoke detection and relay to control center.

Solar BOT Scope Book

2.3.2 Design Basis Document

The Seller shall prepare a site-specific Design Basis Document (**DBD**) in accordance with the Scope Book and Appendices to establish the design summary for the facility. This document will be maintained and revised for the life of the facility as it is key to the management of change process. This document outlines the design basis for achieving the objectives agreed upon by the stakeholders (for example, Seller, Buyer, AHJ, and any local jurisdictions) and the subsequent decision-making process, including:

- Identification of source documents and assumptions,
- Identification of hazards
- Fire protection/prevention features are to be provided or omitted, and
- Operational and administrative controls are assumed to be in place to mitigate operational or natural hazards.

This DBD has been developed specifically for the project description, design parameters, and hazards identified within this document. As each project has unique conditions, parameters, and hazards, this document and the analysis contained within shall not be applied to other projects.

The development of this document is an iterative process and will be revised as the design progresses based on dialogue among the stakeholders. Seller shall create the document at 30% design completion and maintain the document through Closing. Stakeholders establish goals and objectives and evaluate whether the design is adequate to meet those goals and objectives.

Appendix 5 of this document serves as the minimum considerations for the Property protection elements of the DBD. Seller shall input the requested information into the tables in Appendix 5 and should provide any additional information relevant to the parameters of this DBD.

2.3.2.1 Risk Considerations

Hazards associated with PV generating plants to be addressed in the design shall include but not limited to the following considerations:

- Damage assumptions associated with failed PV module connections or string cabling and station equipment response
- Assumptions or failure consequences associated with tracker positioning of the PV modules
- Assumptions for Inverter, switchgear, and cable protection (Flood, Fire, vandalism, etc.)
- Oil filled transformer failures and response for fires and oil confinement
- Safe vegetation height for power production and fires under and around arrays of PV modules
- Flood frequency and maximum depth of water inundation
- Hail maximum survivable diameter and tracker storm safe position assumptions
- Wind design operation and safe position assumptions Seismic activity if applicable

2.4 Civil and Structural

The civil and structural Work is described in the following sections.

2.4.1 Infrastructure and Outdoor Works

Seller shall provide civil works, structures, and foundations for the Project Site, such as:

- Rerouting of existing underground services, such as piping, cabling, and ducts, if appropriate.
- Civil works for discharging rainwater (grading provides positive drainage to rainwater to avoid ponding).
- General site clearing/grubbing, filling, leveling, and grading to the necessary lines and levels and all other earthworks where required including access areas.

Solar BOT Scope Book Main Body

Solar BOT Scope Book

- Construction of new roads, parking areas, and pavement as part of the required infrastructure. The following shall be included as a minimum:
- Main access road(s)
 - Internal roads
 - Collector substation access road(s)
 - Transmission line maintenance road(s)
- Security fence, surveillance system and lighting system
- Access gate(s)
- All civil works for the solar arrays, including:
 - Complete civil works for the solar field, including foundations for the tracker or racking structure and equipment
 - Bollards for sectionalizing cabinets or similar field-placed equipment
 - Crossings (swales, blisters, and culverts)
 - Duct banks
 - Trenches
 - Service roads
 - Onsite infrastructure
 - Permanent erosion control
 - SWPPP compliance
 - Restoration as required
 - Retainage and overflow as required
- All civil works for the collector substation
- All civil works for routing and installation of the transmission line
- Any other outdoor civil works required

2.4.2 Electrical and I&C Systems

Civil works, structures, and foundations for the electrical and I&C systems, including:

- Construction of ducts, culverts, underground cable ducts, trenches, manholes, and other routing methods and access points for medium voltage (**MV**) and low voltage (**LV**) system cables, perimeter lighting, surveillance, I&C system, etc.
- Civil works for equipment such as Power Conversion Systems (**PCSs**), transformers, switchgear, and enclosures, including their corresponding foundations
- Civil works for power evacuation lines from the Project's solar arrays to the collector substation
- Civil works within the collector substation area for power evacuation
- Civil works for the power transmission line from the collector substation to the electrical interconnection point, including tower foundations if required
- Civil works for the electrical interconnection point, if required
- Underground cable for MV and data connections inside of the PV array
- Connecting MV and I&C cables to the agreed demarcation points
- Metering (operational meters, see Section 3.7 below)
- Any other outdoor civil works related to the electrical and I&C systems

2.4.3 Storage

A storage area at the Project Site will be located, sized, and secured for the unloading, storing, accessing, handling, removal, and delivering of supplies, equipment, materials, consumables, and spare parts during all phases of the Project. This includes construction, commissioning, testing, restoration, and

Solar BOT Scope Book

operation and maintenance. Material storage shall be at an elevation above the maximum floodplain for the selected area.

2.5 Mechanical

Racking shall include the following systems and components:

- Supply and assembly of a suitable main tracking structure or fixed-tilt rack and anchor to structure foundations for the specified site conditions
- Supply and assembly of suitable substructure (racking system and/or tracking system) and attachment to PV modules for the specified conditions
- Corrosion protection
- PV module mounting clamps

2.6 Electrical

2.6.1 PV System Circuits

The Work includes the supply, assembly, and installation of, but is not limited to the following components:

- PV modules
- PV string harness
- PV module string connectors
- DC wiring
- Grounding system
- Fused DC combiner boxes or load break disconnects
- DC disconnect switches
- Surge arrestors and lightning protection

2.6.2 Power Conversion System and PV Collection System

The Work includes the supply, assembly, and installation of the following components:

- PCS(s)
 - PV DC to AC power inverter(s)
 - AC disconnect switches
 - Inverter step up transformers
 - Convenience transformer(s)
 - Switchgear (if required)
 - Auxiliary equipment and systems (including HVAC or other cooling systems)
- Backup power supply and Uninterruptible Power Supply (**UPS**) for SCADA and MET stations, tracker stow (if applicable), and other systems if applicable
- Grounding
- Lightning protection system, if applicable
- DC conductors
- Cables
- Relay protection and fuses

2.7 Environmental Requirements

Seller shall design, build, operate, and maintain the Project to meet all applicable /environmental laws and permits, as outlined in the Environmental Guidelines in Appendix 13. Seller shall demonstrate during

Solar BOT Scope Book

the design and construction phase and performance tests that the Project is able to (design) or does (construction) comply with all applicable environmental laws and permits. Applicable standards for environmental protection must be fulfilled without any restriction.

Seller shall conduct studies and necessary evaluations for activities commonly associated with new construction, including but not limited to:

- Conduct Environmental Assessments (**EA**) in compliance with Good Industry Practices and current requirements and Laws
- Conduct Wetlands Delineation and Threatened and Endangered Species Survey
- Conduct a site flood assessment
- Develop National Pollutant Discharge Elimination System (**NPDES**) Construction Stormwater Permit
- Develop Stormwater Pollution Prevention Plan (**SWPPP**)
- Develop Spill Prevention, Control, and Countermeasures (**SPCC**) Plan for project construction activities
- Hazard communication and chemical storage requirements found in 29 CFR 1910.1200
- Waste Management for non-hazardous, hazardous, and universal wastes.
- Waste management for broken, damaged, or waste solar panel modules
- Above ground storage tanks
- On-site sewage facilities (Septic Systems)
- Develop environmental considerations report as required by State Public Utility Commissions
- Develop site emergency response guide

2.8 Site Security – Construction

The Site Security Plan developed in accordance with the Agreement shall include the following:

- Project Site access gate with interface for manual key entry
- Locks on any building or enclosure on the Project Site that contains microprocessor-based relays

Seller shall ensure the security systems comply with all requirements of law and applicable permits.

Seller shall be responsible and maintain care and custody of all project equipment, tools, and material after delivery and acceptance and until project turnover.

2.9 Temporary Site Installations and Laydown Areas (Including Buyer's Dedicated Office Trailer)

Seller shall obtain all necessary approvals and/or permits for the installation of the temporary site installations and laydown areas.

Seller shall maintain site cleanliness and perform housekeeping in accordance with good industry practices.

Seller is responsible for the mobilization of field forces and all necessary construction facilities at the Project Site, including temporary office trailers as necessary or advisable for completion of the Work.

Seller shall provide dedicated temporary office trailer for Buyer's use from mobilization to substantial completion, complete with reliable 24/7 power, potable water, sewer, restroom facilities with flushing toilets, and broadband internet. Janitorial service shall be provided for Buyer's trailer weekly. After substantial completion, Buyer shall have an option to assume contractual obligations for this temporary office trailer.

Promptly after the substantial completion payment date and as a condition to final completion, Seller shall remove all temporary installations and demobilize, leaving the Project Site clean and orderly, and clear of debris or pollution. Any laydown, construction parking, and/or work areas constructed on a temporary basis shall remain for future use.

Solar BOT Scope Book

2.10 Tools, Spare Parts, and Consumables

Seller shall provide all equipment and tools, including cranes, lifting equipment, and special tools, necessary for operation and maintenance of the plant through the substantial completion payment date.

In addition to the transferred closing inventory and any transferred post-closing inventory outlined in the Agreement, Seller shall provide a list of recommended spare parts and consumables, including the list price of each item. The recommended spare parts and consumables should be classified in a list as follows:

- Maintenance spares and consumables: Items Seller reasonably anticipates may be required or appropriate for Buyer to have in stock during the first two years of normal operation of the Project.
- Overhaul spares and consumables: Items Seller reasonably anticipates may be required or appropriate for Buyer to have in stock during the programmed minor and major overhauls.
- Strategic and breakdown spares: Items Seller reasonably anticipates may be required or appropriate for Buyer to have in stock after commissioning and before extensive testing to refurbish the equipment.

Seller shall be responsible for supplying and fitting any spare parts required during construction, commissioning, and testing without charge to Buyer.

For all categories of spare parts and consumables, Seller shall recommend in accordance with good industry practices proper storage procedures for all items.

Following receipt of such list, Buyer shall inform Seller of the spare parts and consumables for operations that it is electing to maintain (whether that is the full list provided by Seller or a modified list). Seller will support Buyer's review and finalization of such list. Following finalization of the list of such spare parts and consumables for operations that Buyer is electing to maintain, Seller shall, for Buyer's account and at Buyer's direction and cost, manage the procurement and delivery to the site designated by Buyer of such spare parts and consumables.

3 Technical requirements

3.1 General System Requirements

Seller shall perform and complete the Work in a thorough, professional manner utilizing personnel skilled, competent, and appropriately licensed in their various trades. The Project design shall comply with the requirements stated herein. All equipment, materials, and components shall comply with the requirements of this Scope Book.

No aspect of Project operation shall produce Electromagnetic Interference (**EMI**) that will cause faulty operation of instrumentation, communication, or similar electronic equipment within the Project or elsewhere on the [Entity]Transmission System. The Project shall be designed to suppress EMI effects and must meet the specifications of the latest revision of IEEE 519.

3.2 Civil and Structural Requirements

3.2.1 General

PCS and other high-profile electrical equipment shall be placed at the Project Site in a manner to prevent or, if not possible, minimize shading on the PV modules. Adjacent property use and future tree line shading should be considered in the site layout.

Solar BOT Scope Book

3.2.2 Accessibility

3.2.2.1 Access at the Project Site

The Project shall be designed, constructed, and installed with sufficient access aisles, equipment separation, and clearance to ensure the safe operation, maintenance, inspection, repair, removal, and replacement of equipment and systems including pull space.

The design shall give priority to the economic management of vegetation and long-term operation and maintenance cost and safety.

The Project design shall include and allow for appropriate walkways, forklift and vehicle runs, access routes, means of access, and related safety protections, including doors, stairs, landings, ladders, and other access means.

Reasonable access shall be provided for systems components and equipment that require regular or anticipated maintenance activities or operator access for normal operations or repair of the Project. All platforms shall provide space for maintenance of equipment and pull-space.

3.2.3 Geotechnical Investigation

Seller shall conduct geotechnical investigations on the Project Site. The results of the investigations shall serve as a basis for the Project's civil, structural, and architectural design, including identifying the required foundations and earthworks, selection of materials and corrosion protection methods, trench and cable sizes, erosion potential, or any other aspect in which soil characteristics are relevant.

Geotechnical investigation shall include specific guidance for site road construction, steel corrosion, and driven piles.

A geotechnical analysis shall be provided by Seller and performed by a qualified geotechnical engineering firm. The required number of boreholes and location shall be determined by the engineer to meet project design requirement. An engineering firm shall prepare a hydrology report.

In addition to the above minimum requirements, local jurisdictional regulations may require site specific hydrologic and infiltration testing. Seller should determine specific requirements and coordinate with geotechnical engineering firm to obtain any required testing information, related to proposed stormwater management facility designs.

A detailed geotechnical report shall be provided outlining the tasks performed and the results of the testing. Included in the report should be any recommendations for the foundation designs, structural support designs, corrosion protection for both underground steel and concrete, pile drive frequency, minimum pile size, and any geologic conditions that may prevent the development of the Project. Geotechnical report shall include recommendation of type of cement to be used based off the sulfate content to meet concrete durability and design life of foundations.

The procedure shall include performing onsite resistivity testing and conducting laboratory analyses on soil samples collected from the site. Seller shall ensure the number and type of soil samples is representative of the overall project site and accounts for the areas with most aggressive exposure. Perform laboratory testing to determine saturated electrical resistivity, pH, and chloride and sulfate concentrations.

3.2.4 Site Clearing, Grading, Soil Improvement, and Revegetation

Seller shall design the general grading of the Project Site considering the requirements of the selected trackers or racking system and the needs of the general drainage system. Seller shall ensure all Project

Solar BOT Scope Book

grading and drainage, and access roads are designed to the requirements of all laws and applicable permits.

Earthwork (excavation, fill, backfill, slopes, etc.) associated with grading and drainage, including materials, installation, and testing, shall be conducted in accordance with the final geotechnical data and as reasonably determined by Seller's geotechnical engineer(s) for the Project. Construction damage to earthwork shall be remediated prior to Substantial Completion.

Seller shall provide for the inspection and testing of all load-bearing surfaces (foundations, slabs, roadways, trench bottom, etc.) by qualified, experienced, properly licensed independent inspectors.

Backfill for trenches shall be selected to prevent physical damage to raceways or cables. The backfill of trenches shall be tested for design compaction requirements and shall meet the requirements of the Geotechnical Report.

Refer to Appendix 13 for further requirements regarding waste management, soil stabilization, and seed mix amongst other pertinent topics.

Seller shall obtain all required Project work permits and Project operational permits from applicable governmental authorities. Seller shall locate the Work from horizontal and vertical control monuments. If the removal or relocation of utilities is required, Seller shall notify utility companies.

Seller shall protect structures, utilities, sidewalks, pavements, and other facilities from damage caused by earthwork operations, soil conditions, or environmental conditions.

Seller shall provide erosion-control measures in accordance with the approved Project Stormwater Pollution Prevention Plan (**SWPPP**) for the Project to prevent or mitigate erosion or displacement of soils and discharge of soil-bearing water runoff or airborne dust to adjacent properties, including roads, walkways, waterways, and wetlands.

3.2.5 Construction Materials

All materials shall be of good quality and capable of withstanding the environmental and subsoil conditions they will be exposed to during the life span of the asset without any significant decrease in serviceability or strength.

3.2.6 Drainage and Stormwater Management

The Seller shall be responsible for developing, constructing, and maintaining through the substantial completion date a Project Site stormwater management plan that meets all laws and applicable permits. Seller shall conduct a topographical survey to define the general drainage for the Project Site and use the survey as a basis for the design of the Project Site stormwater management plan. Seller shall complete and submit all necessary permitting applications, including stormwater discharge National Pollutant Discharge Elimination System permit applications, to the appropriate governmental authorities. The stormwater management plan, the Work, and the Project shall comply with all such permits as outlined in Appendix 13.

Seller shall develop, design, engineer, and construct an adequate drainage system, including any necessary inlets, pipes, channels, manholes, stormwater swales, surface flow, outlets, or other components for collecting, directing, and disposing of stormwater from the Project Site. Site drainage during construction shall be designed so inundation due to a 100-year 24-hour storm event subsides within 48 hours. A clear path for the collected stormwater out of the Project Site shall be provided, without flooding, while complying with all laws (including codes and standards) and permits.

Within 96 hours after 25 year 24 hour rainfall event, 90% of roadways must be clear of standing water and no more than 10% of roadways shall have more than 3" of standing water.

Solar BOT Scope Book

Stormwater runoff shall replicate existing pre-development stormwater runoff to the greatest extent possible. Modification of existing hydrologic conditions due to construction/development shall not result in an increased potential for flooding (upstream or downstream) or adverse drainage, negatively impact water quality or unnecessarily impact other uses in the vicinity. There should be no net increase in quantity, frequency, and / or duration of storm water runoff pre and post construction/development. Any contaminated runoff shall be segregated and detained separately in strict accordance with all laws and applicable permits. Permanent stormwater drainage systems shall be designed to carry the storm return period as required by all.

Underground piping and culverts shall be Reinforced Concrete Pipe (**RCP**), aluminized corrugated metal pipe, or corrugated, dual-wall, High Density Polyethylene Pipe (**HDPE**). The hydraulic grade line for the stormwater pipeline system shall be as required by all laws and applicable permits. Ditches shall be lined with vegetation, rip-rap, and/or concrete, as applicable, based on the water velocity.

All areas not drained via a stormwater drainage system shall be drained via an open-ditch system consisting of trapezoidal ditches with culverts or grating at road crossings or, where slope can be achieved, sheet flow.

When culverts are utilized, the culvert inlets and outlets shall be provided with end sections and permanent erosion protection.

Project Site areas not included in or affected by the Project shall be left in their existing conditions.

3.2.7 Erosion Control

An erosion and sediment control plan shall be developed by Seller's professional engineer licensed in conjunction with the SWPPP for the construction phase of the Project. During Project construction, erosion and sediment control measures shall be implemented to prevent sediment-laden runoff from leaving the Project Site. Construction runoff shall be directed to the erosion and sediment control systems prior to leaving the Project Site. The plan shall include, at minimum, the incorporation of silt fencing, silt bags, straw bale dikes, storm inlet protection, sediment basins, swales, piping, stream crossings, and other measures as required or appropriate to promote sediment and erosion control as prescribed in the approved plan and/or by periodic inspection by the local soil conservation district. Silt bags or reasonable equivalent shall be included as necessary when dewatering excavations to prevent sediment from collecting in the stormwater system (e.g., Seller shall not pump silt-laden water through the stormwater system without proper filtration).

3.2.8 Foundations

Foundations shall be designed, constructed, and completed to consider the site climatic conditions (heat, cold, rain, earthquake, ice, and wind), soil conditions, and thermal loads caused by expected fluctuations of materials and ambient temperatures.

Foundations for outdoor electrical equipment shall be elevated above ground to prevent any equipment, parts, systems, or other items (excluding the foundation) from coming in contact with surface water or runoff. The minimum height of the above ground portion of any such foundation (measured from the top of ground level to top of concrete) shall be the greater of:

- The height required based on the results of the 100-year maximum flood hydrological study for the Project and Project Site plus an additional 6 inches of freeboard
- 12 inches

Solar BOT Scope Book

3.2.9 Corrosion Protection

Seller shall account for the corrosion of steel components on structures and pile foundations that are expected to be encountered on the Project Site. Seller shall galvanize all steel structures, steel foundations, and their components. No bare steel structures or components are allowed.

Seller shall use ASTM A123 (From ASTM A123 Table 1: W6x9 – grade 75: 3 mils, W6x9 grade 85: 3.3 mils) for the minimum coating thickness on all hot dipped steel sections including steel piles. A minimum of 3.0 mils of galvanizing shall be used on all piles. All fasteners and bolts shall be galvanized using an ASTM approved methodology such as Hot-Dip Galvanization or Zinc-Flake Coating.

Galvanization thickness greater than 3.9 mils up to 5.0 mils are acceptable on steel sections and components if the Corrosion Engineer and the pile Engineer of Record provide written confirmation from the galvanizer that they will be able to achieve such a nonstandard coating thickness on the steel components and that the quality and adhesion strength will be in accordance with ASTM A123.

3.2.9.1 Corrosion Rate Estimation Methodology and Requirements

Estimate the corrosion rates of buried ferrous structures in the soil using a similitude analysis.

Foundation design life is the same as the Project design life as defined in Appendix 5.

Use the corrosion database compiled by Melvin Romanoff in the National Institute of Standards and Technology (formerly National Bureau of Standards (**NBS**)) Circular 579 entitled Underground Corrosion². This procedure requires some corrosion knowledge and experience and shall only be performed by a Corrosion Engineer³.

The procedure shall include performing onsite resistivity testing and conducting laboratory analyses on soil samples collected from the site. Seller shall ensure the number and type of soil samples is representative of the overall project site and accounts for the areas with most aggressive exposure. A minimum of 1 resistivity test shall be performed on site per 25 acres. Perform laboratory testing per the following standards: saturated electrical resistivity values per American Water Works Association (**AWWA**) G187, pH per AWWA G51, and chloride and sulfate concentrations per ASTM D4327. Report the results.

A soil in the corrosion database shall be selected that most closely matches the worst-case onsite parameters in the soil samples. It may be necessary to select two or more soil samples based on site heterogeneity. Select the sample(s) with special emphasis on the following parameters:

- Lowest electrical resistivity
- Lowest pH
- Highest concentration of chloride ions
- Highest concentration of sulfate ions
- Geographic location
- Site drainage conditions

² Romanoff, Melvin. (1989). Underground Corrosion, NBS Circular 579. Houston, TX, United States of America: Reprinted by NACE.

³ The Corrosion Engineer is herein defined as a licensed Professional Engineer with certification or licensing that includes education and experience in corrosion of buried or submerged metal structures, or a person certified by NACE International at the level of Corrosion Specialist or Cathodic Protection Specialist (i.e. NACE International CP4). The Corrosion Engineer shall have not less than five years' experience with corrosion control at solar facilities.

Solar BOT Scope Book

Use the corrosion database to estimate the uniform corrosion rates after selecting the soil sample(s). If multiple soil samples are selected report the highest corrosion rate amongst the soil samples.

- Report the steel corrosion rate in Mills Per Year (*mpy*)
- For galvanized steel, estimate the corrosion rate of zinc and steel separately and report in mpy; and
- Utilize a safety factor of 1.5 on the calculated corrosion rate when reporting the corrosion rates.
- Calculate the anticipated section loss of the steel substrate based on the corrosion rate and desired service life. Include this value in the design as the corrosion allowance.
- On galvanized piles subtract the consumption life of the zinc layer from the structure design life and calculate the steel corrosion rate on the remaining years.
- Consider the structure geometry to determine if the corrosion progresses from one side or both sides. For example, for an H-beam section, multiply the corrosion rates by 2 to account for corrosion progression occurring from both sides of steel surfaces exposed to soil (referred to as “two-sided” corrosion rates). The corrosion rate for hermetically sealed pipe piling where only the outer steel surfaces are exposed to soil is “single-sided” and do not need to be multiplied by 2.
- The localized corrosion rates listed in the corrosion database can be disregarded unless pitting and localized corrosion penetration could either compromise the structure integrity during the service life of the structure or alter the estimated corrosion rate. For example, a through-wall pit in a pipe pile would cease to be hermetically sealed and a single-sided corrosion rate would not be appropriate.
- There are other corrosion mechanisms such as galvanic coupling between steel piles and copper grounding, and pH concentration cells between steel piles and concrete pile caps. Either include corrosion allowances for these mechanisms or ensure the design prevents these mechanisms from occurring.

An alternative method for determining the corrosion rates is to perform Linear Polarization Resistance (**LPR**) laboratory testing per ASTM G59 or with suitable proprietary instrumentation that integrates the Stern-Geary equation. This method also requires representative soil samples from the project site.

- Ensure that the LPR testing is conducted by a qualified laboratory with a minimum of 5 years of experience performing such tests. Submit documented experience along with proof of up-to-date device calibrations along with the results.
- Report corrosion rates for both steel and zinc in mpy
- Report initial and steady state corrosion rates.
- If utilizing proprietary instruments additionally report the imbalance, which is a measure of pitting tendency.

Calculate the anticipated section loss as detailed above.

Seller shall provide calculations for galvanization thickness and corrosion allowance steel structures in contact with soil for the stated design life of the plant. The depletion rate for galvanization and steel loss after depletion of galvanization shall be considered constant over the life of the plant using the values developed by Romanoff in “Corrosion of Galvanized Steel in Soils.”

3.2.10 Roads

Roads shall be constructed using minimum construction requirements as shown in Table 4.

The Project design shall provide for, and the completed Project shall allow a 35-foot class 8 truck access with the ability to turn around at intersections for all roads. Road Design shall also allow for Delivery truck/trailer and 100-ton crane for the non-standard event of a PCS skid or PCS major component replacement to those equipment areas. An AutoTURN feature shall be used in AutoCAD to show final design accommodations.

Solar BOT Scope Book

Figure 2: AutoTURN example of a fire truck turn-around pad using a three-point turn

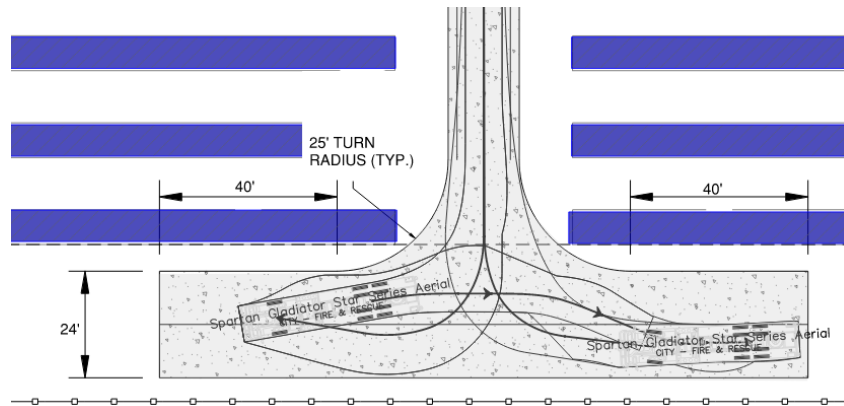

The road conditions must meet IFC Section 503 as well as all the requirements detailed below. Figure 2 above depicts the completed AutoTURN with the mentioned turn and turnaround requirements given the listed minimums.

- Road width: minimum 12 ft (with 2 ft shoulders)
- Turn radius: minimum 25 ft inside diameter
- Turnaround requirements: Required, through road available preferred
- Turn around pad dimensions: 24 ft x 40 ft

Roads and bridges shall be designed in accordance with the requirements of codes, including the International Fire Code, law, and applicable permits. A geotechnical engineering report shall include recommendations for site roads to accommodate planned vehicle access for construction and operations, including a class 8 vehicle. Adjustments to road width from minimum detailed below will further update the turn radius to ensure drive path can meet vehicle requirements.

Solar BOT Scope Book

Table 4: Road construction requirements

Road Description	Lane Width Requirements	Turn Requirements	Construction details
Main Entrance Road to Project Site	Road Width – 20 ft Shoulders – 2 ft Total Width – 24 ft	Must support largest vehicle accessing the site through this entrance.	<ul style="list-style-type: none"> • Road base must be stabilized and compacted • Must meet recommendations from geotechnical engineering report; however, at a minimum, two lifts of four inches each of aggregate with compaction on each lift (for a total of eight inches of aggregate) shall be used
Road to Collector Substation	Road Width – 20 ft Shoulders – 2 ft Total Width – 24 ft	Must support a minimum inside turn radius of 50 ft or required minimum of largest vehicle accessing the substation.	
Access Roads to Each PCS	Road Width – 12 ft Shoulders – 2 ft Total Width – 14 ft	Tractor trailer and/or crane to enter and exit (backing up acceptable) once project is constructed.	<ul style="list-style-type: none"> • Must meet recommendations from geotechnical engineering report; however, at a minimum, road base must be stabilized and compacted and two lifts of three inches each of aggregate with compaction on each lift (for a total of six inches of aggregate) shall be used

Where a new road meets an existing road, the width of the new road shall smoothly transition back to the width of the existing road.

Vertical clearances above roadways for transmission lines shall be at least 20 feet unless additional clearances are required for special equipment access or other design requirements.

The existing grade of any road shall be compacted to a level specified by the engineer of record or replaced and compacted with suitable material, if necessary, and the sub-base, base, and pavement layers selected to provide sufficient bearing capacity to withstand the intended traffic and use. Roads shall comply with American Association of State Highway and Transportation Officials (**AASHTO**) requirements. Road surfaces for the Project Site shall be designed based on the recommendations from the final geotechnical report and the engineer of record.

Seller shall be responsible for checking any possible limitations on the transportation of sensitive material, heavy equipment, or other items to be delivered to the Project Site or use of vehicles or other modes of transportation due to the loading capacities and clearances of existing bridges and roads linking the roads, waterways, or other places to the Project Site.

3.2.11 Fencing and Gates

Seller shall ensure the perimeter of the Project Site is completely fenced by utilizing either a seven-foot-tall “farm style”, “wildlife style”, or “deer style” fence or a six-foot-tall chain link fence topped with a three-strand barbed wire (creating a total fence height of seven feet). The Seller shall ensure there are no ground gaps greater than two inches and the fence is secure. Signs in accordance with Section 7.3. If permits require specialty fencing for wildlife or species concerns, fencing shall comply with recommendations and/or requirements from permitting. All posts, rails, fabric, wire, and gates shall be

Solar BOT Scope Book

galvanized. Steel fence posts shall have wall thickness suitable for pile driving and shall meet corrosion requirements for the project as outlined in section 3.2.9.

Features of the motor operated sliding gates shall include the following:

- Sliding gate shall be four (4) feet greater than entrance road
- An electric gate operator (Lift Master Elite or better), including associated items
- A hard-wired continuous power connection (if available)
- A hard-wired keypad gate opener (not wireless) located at the gated entrance (exterior side of the PV Project Site fence)
- A pedestal mount, conduits, and wiring at the gated entrance and exit
- A hard-wired push-button gate opener located at the gated exit t (interior side of the PV Project Site fence exit ground loop not required)
- Sliding gate shall be grounded in accordance with the following:

Swing gates shall be four (4) inch greater than entrance road.

All other gates shall be secured with a high security chain and a high security padlock.

Fencepost for gates and transitions/pull fencepost shall be concrete poured. Fence posts may be pile driven.

3.2.12 Parking and Access at the Project Site

Seller shall be responsible for assuring parking areas are included next to all buildings and enclosures required for the Project based on Seller's final design. The quantity of parking spaces shall be sufficient for six vehicles. Surfacing requirements for parking areas shall conform to the general requirements for roads.

Seller shall be responsible for ensuring adequate parking is available for Project construction and commissioning staff, and parking and access areas are sufficient for all construction and commissioning activities, including lifting of heavy loads.

3.2.13 Buildings on the Project Site

Buildings at the Project Site shall be designed in accordance with the requirements of all laws and applicable permits. Construction materials used in Project buildings and enclosures shall meet the definition of non-combustible or limited combustible, except roof coverings, which shall be Class A in accordance with standard methods of fire tests of roof coverings. Metal roof deck construction, where used, shall be "Class 1" or "fire classified." The local fire protection and National Fire Protection Association (**NFPA**) rules and recommendations shall be followed for the fire safety design and fire protection systems. The collector substation control house is specified in Appendix 11.

Minimum separation of permanent site equipment and support structures shall be in accordance with NFPA 80A assuming no fire response.

Particular attention shall be focused on sloping floors and roofs and adding drains around equipment to preclude any pooling of water and flashing to preclude water penetration inside the building.

If used, seller shall ensure fire-rated barriers and appropriate fire seals are installed in openings per the design.

Seller shall provide and incorporate noncombustible or fire-rated raceway sealing materials for all cable penetrations entering or exiting electrical enclosures or structure at the Project Site consistent with NEC (Power Distribution Center, new or existing offices, transformers, control structures, other installed equipment, etc.).

Solar BOT Scope Book

An adequately designed HVAC system that considers the specific needs of every room and the climatic conditions set forth in Section 1.2.1 shall be installed.

3.3 Electrical Requirements of the Project Site

3.3.1 General Requirements

Protective relaying, metering, and controls for all electrical equipment shall be according to industry standard metering and relaying, including North America Electric Reliability Corporation (**NERC**) compliance, applicable codes and standards, and other requirements of the performance standard. Capacitor banks may be used to meet the power factor at the Point-of-Interconnect (**POI**) according to the GIA.

3.3.2 Cables

All cables shall be fire-retardant, and self-extinguishing, with Cross Linked Polyethylene (**XLPE**) isolation where required. For buried cable, anti-rodent additives shall be included for cable protection. In lieu of anti-rodent cabling, other rodent mitigations may be allowed pending Buyer approval.

All cable (regardless of voltage level and use) shall have a fire-retardant jacket and shall have successfully passed the appropriate (IEEE, American Society for Testing Materials (**ASTM**), or Underwriters Laboratories (**UL**)) flame-spread and smoke-generated test for the class, voltage rating, and size of the specific cable.

3.3.2.1 DC Cables

PV DC wiring shall be UL listed as PV wire and meet UL 4703 requirements.

Conductors shall be rated for 2,000 V_{dc}, 90°C, wet rated, sunlight-resistant and rated for direct-burial.

PV source circuit conductors shall be multi-strand copper, minimum 12 American Wire Gauge (**AWG**).

DC wiring conductors shall be copper for #8AWG or smaller, and either Aluminum or Copper for larger than #8 AWG.

Conductors shall be sized to ensure peak losses of the DC system are below 2% (on average) and to avoid excessive voltage drop.

3.3.2.2 Low Voltage AC Cables

AC cables shall be rated for the correct maximum voltage and sized according to the operating and short-circuit currents. All low voltage 600 V cables are copper and XHHW-2 insulated.

Conductors shall be sized to ensure peak losses are below 2% (on average) and to avoid excessive voltage drop.

Insulation shall be adequate for the climactic and environmental conditions of the Project as listed in Section 1.2.

AC cables shall adhere to local authorities having jurisdiction and applicable standards, including IEEE and UL, for the voltage class. Dual class rating is prohibited.

3.3.2.3 Medium Voltage AC Cables

AC cables shall be rated for the correct maximum voltage and sized according to the operating and short-circuit currents. MV Cables are MV-90 or MV105, TR-XLPE or EPR, 100% or 133% insulation, with

Solar BOT Scope Book

concentric neutral to be sized for maximum ground fault. MV cables are UL listed and according to the standards in Section 3.3.2.4 as a minimum.

3.3.2.4 Medium Voltage AC Cable Specifications

- ASTM B231 Standard Specification for Concentric-Lay-Stranded Aluminum 1350 Conductors
- ASTM B609 Standard Specification for Aluminum 1350 Round Wire, Annealed and Intermediate Tempers, for Electrical Purposes
- ICEA S-94-649 Standard for Concentric Neutral Cables Rated 5 through 46 kV
- AEIC CS-8 Specification for extruded dielectric shielded power cables rated for 5 through 46 kV

3.3.2.5 Medium Voltage AC Cable Construction

- Conductor: Moisture-blocked class B compressed aluminum ASTM B231 1350 .75 hard H16/H26
- Conductor shield: Conventional semi-conducting, cross-linked copolymer; supersmooth conductor shield optional; a conductor tape is used for cable size larger than or equal to 1500 kcmil
- Insulation: 345 mils tree-retardant, cross-linked polyethylene (TRXLPE), 100% insulation level
- Insulation shield: Strippable semi-conducting, cross-linked copolymer
- Concentric neutral: Helically applied soft-drawn, bare copper one-third concentric neutral
- Overall jacket: Linear Low-Density Polyethylene (**LLDPE**) jacket, black with red extruded stripes

3.3.2.6 Cable Management

MV AC cable shall be direct buried and in conduits where required under access road or under equipment foundation. DC cable may be either direct buried or a CAB system may be used and in conduits under the pad foundation. All above grade cables (e.g., CAB system) shall be 18 inches above grade at maximum sag, to allow clearance for maintenance. All 600 V cables are to be installed in conduits. All conduits to be Schedule 40 PVC underground and Schedule 80 PVC UV-resistant above ground. All sections of conduit shall have an inside chamfer at both ends and shall be closed to be watertight and prevent animal entry.

All direct-buried cables must be installed:

- In compliance with National Electrical Code (**NEC**) 300 requirements and guidelines, including NEC 300.5.
- Buried at a minimum depth of 36 inches below the ground surface for MV with 3 inches min of filtered native soil underlayment. PV cables and 600 V cable circuits can be installed at shallower depth the NEC if installed at a distance of at least four inches from rocks or stones that are ¾ inch or more in size.
- At a distance of at least four inches from rocks or stones ¾ inch or more in size.
- Where direct bury cables transition above grade, protect by conduit to a height of 18 inches above grade

DC cables running the length of the torque tube above ground, such as module cables and string cables, shall be routed and secured to the tracker torque tube, racking, or PV modules AL frames either using dedicated cable trays, torque tube ratchet clips, or stainless-steel clips to the underside of the applicable racking structure and to the applicable torque tube. Cables shall be protected from direct sun exposure, standing or dripping water, and abrasion by any edges of the tracker or racking. Seller to perform a golden row for Buyer to review and approve. All wiring under a tracker row shall be installed in neatly arrangement and be accommodated for PV module rotations. . Cables shall be suspended in a manner which prevents mating connectors from being submerged or contacted with standing water. Mating connectors shall be elevated to the greater of:

- The height required based on the results of the 100-year maximum flood hydrological study for the Project and Project Site plus an additional 6 inches of freeboard

Solar BOT Scope Book Main Body

Solar BOT Scope Book

- 12 inches

Where mating connectors are not of the identical type and brand, they shall be listed, identified, and type certified for intermateability. Field installed connectors will not be allowed. Field to fit jumpers will not be allowed. Jumpers shall be prefabricated in a controlled manufacturing environment based on design drawings.

3.3.2.7 DC and AC Circuit Conduit

All aboveground DC circuit conduit within the array shall be rigid PVC conduit, schedule 80, with threaded adapters. Add expansion joints for all risers and fixed terminations as required by code. All terminations at the bottom of cabinets to include appropriate sealing material.

All terminations shall occur at the bottom of cabinets and include appropriate sealing material.

The cable runs between rows and to the combiner boxes or load break disconnects may be direct buried or hung using a CAB system, as provided in Section 3.3.2, including Section 3.3.2.6, and transition directly from the row to the combiner box or load break disconnect at the end of the row.

The combiner box or load break disconnect at the end of a row shall be no more than three feet from the end of the row and must be directly in line with the row.

Combiner boxes or load break disconnects shall be above the greater of:

- The height required based on the results of the 100-year maximum flood hydrological study for the Project and Project Site plus an additional 6 inches of freeboard
- 12 inches

Plastic bushings with locking nuts shall be used for all exposed threads.

All sweeps and transitions from below ground to above ground shall be rigid Polyvinyl Chloride (**PVC**) conduit, schedule 80 to a height of 18 inches above grade. All sections of conduit shall have an inside chamfer at both ends.

Low Voltage AC conduit shall be rigid galvanized steel conforming to the American National Standards Institute (**ANSI**) C80.1 and UL 6.

All below grade and concrete encased conduit (DC or AC) shall be rigid schedule 40 PVC or SDR 11 HDPE.

Seller shall provide pull boxes and conduit bodies to facilitate wire pulls and maintain compliance with NFPA 70.

3.3.3 Lighting

At a minimum, lighting shall be provided in the following areas:

- Entrance gate
- Seller's control house (if in scope of work)

Emergency lighting shall be provided by integral battery packs and automatically energize on loss of AC power to provide for safe egress and light occupied control rooms and other critical areas. Illumination levels shall satisfy OSHA standards for their given service and location. Luminaires shall be standardized as much as practicable to reduce the number of components the Project must stock.

Solar BOT Scope Book

3.3.4 Grounding

A comprehensive soil resistivity measurement shall be performed in accordance with IEEE Standard 81. All exposed equipment shall be fully grounded and bonded in accordance with law, applicable permits, the requirements of any governmental authority, and the applicable standards listed in Section 1.3.

Solar arrays shall be installed in accordance with the original equipment manufacturer's recommendations for grounding and bonding.

All LV and MV electrical equipment bonding will be bonded to the grounding ring or mat and be designed in accordance with the applicable standards listed in Section 1.3.

PV trackers shall be UL 2703 and UL 3703 compliant. Racking systems shall be UL 2703 compliant. Seller to provide Buyer UL certificate. The trackers shall incorporate integrated NEC and UL required grounding.

Safe step and touch potential of the perimeter fence shall be verified by an IEEE 80 compliant grounding study. Appropriate grounding and isolation shall be installed per drawings and applicable standards

3.3.4.1 Fence Grounding

Fencing around the perimeter of the overall Project Site shall be grounded in accordance with IEEE 80, NEC, and local codes.

A perimeter ground shall be located 3 feet outside of the project fence. Every fourth fence post shall be bonded to the ground grid. Fence fabric and barbwire strands do not require grounding. Fence posts shall be tied to the grid using a welded or bolted ground clamp attached to the inside web. Corner posts shall be bonded to the ground grid using a welded or bolted connection.

Fences may be grounded using one of the below approved methods:

- Tie the fence to the project ground grid
- Place horizontal ground wires for gradient control inside, under, or outside the fence.

If the fence is not tied to the project ground grid, it shall be tightly bonded to its own grounding system, (i.e., loop conductor and ground rods). Fence shall be completely metallically isolated. The following factors shall be considered:

- Accidental energizing through a fallen conductor.
- Induced potentials during other types of faults (coupling through the soil).

3.3.4.2 Swing Gate Grounding

All swing gates, including vehicle drive through and personnel walk through gates, shall be bonded to the gate post using an insulated 4/0 AWG flexible cable such as CADWELD FJ2G24 or FJ2Q24. If the gate post and gate frame is schedule 40 or larger steel pipe, direct exothermic connections to the steel shall be used.

All gate posts shall be bonded to the grid using an exothermic connection per the ground grid design.

Solar BOT Scope Book

All gate areas shall contain 4/0 AWG copper ground mesh that extends 3 feet past the maximum gate swing area.

3.3.4.3 Horizontal Slide Gates Grounding

Sliding gate panels shall be grounded. Vanquish Sliding Gate kit or Festoon Systems are acceptable, for Festoon Systems, rail system shall be installed to prevent rotation. V-track for the sliding gate shall be grounded to the grid.

3.3.4.4 Private Fences

Project fences shall not be closer than 10 feet to any metallic component of a privately owned fence. Where not possible to maintain 10 ft of distance Seller shall propose methodology for isolation of fence.

3.3.5 Lightning Protection

Lightning protection for buildings shall be provided in accordance with NFPA 780, IEEE Std. 998-2012, and UL 96A. Lightning protection shall also be provided for major electrical equipment where applicable. Master Labels shall be provided for structures that require lightning protection.

3.3.6 Interconnection Requirements

Project to comply with the interconnection requirements set forth in the GIA. Notable requirements include reactive power requirements of +/- 0.95 per FERC 827.

3.4 Main Equipment Requirements

All equipment described in this Section shall be supplied by one of the approved vendors listed in Appendix 9, subject to the other terms of the Agreement. Appendix 6 of this Scope Book sets forth the complete datasheets for the Project's key equipment. The design, materials, manufacturing, construction, testing, cleaning, coating, and packaging of all equipment and components shall comply with the applicable standards listed in Section 1.3.

3.4.1 PV Modules

PV modules shall be handled and installed in accordance with the manufacturer's installation guidelines.

Seller shall take necessary precautions to ensure that the modules are installed at the Project (or included in inventory/storage) do not degrade or experience diminished performance as a result of microcracking, micro fracturing, or similar damage.

The PV modules incorporated into the Project shall have a proven track-record in terms of technology performance, durability, and resistance to similar climatic conditions to the Project Site.

PV modules shall be suitable for climatic conditions described in Appendix 5.

The PV modules included in the Project must be certified to International Electrotechnical Commission (**IEC**) 61215, and IEC 61730 by a Nationally Recognized Testing Laboratory (**NRTL**).

PV modules included in the Project must be certified to UL 1703, including without limitation, the Class C Fire Rating pursuant to UL 790 and UL 1703 by a recognized NRTL (listing by other nationally recognized test laboratories such as ETL or CSA will not be accepted).

Module shall be UL listed for the planned voltage (1,500 Vdc).

Solar BOT Scope Book Main Body

Solar BOT Scope Book

Modules shall meet minimum efficiency of at least 20.5%.

PV modules shall be UL 1703 Type 1, Type 2, Type 3, Type 10, or Type 13. Use of any other UL 1703 type will require the prior written approval of an authorized representative of Buyer prior to use.

Seller shall provide a recommended procedure for disposal of the PV Modules at the end of their useful life.

PV Modules shall have a power tolerance of +5 W and -0 W or better.

Seller shall provide factory flash test results including serial number, model number, manufacturer date, ISC, VOC, IMP, VMP, PMP, and fill factor. Factory flash test results to be provided upon commissioning.

PV modules may be rejected for visible damage including but not limited to bubbles, delamination, yellowing, browning, bending, breakage, burning, oxidation, broken or cracked cells or glass, corrosion, discoloration, anti-reflection, water damage evidenced by a water line, and misalignment.

3.4.2 Single Axis Trackers

Seller shall utilize a single axis tracking⁴ system for the trackers.⁵ The tracking system shall be designed, built, and maintained to minimize interference with the free movement of equipment, including vegetation management equipment, or personnel between any rows of the Project. Each tracker shall be designed to resist all imposed loads in all possible working conditions as per the applicable standards and the conditions listed in Section 1.3.

Trackers shall be designed to ASCE 7, risk category III

3.4.2.1 Single Axis Tracker Systems

The leading front edge of the PV module when the tracker is in full tilt shall be elevated at a minimum to the greater of:

- The height required based on the results of the hydrological study for the Project and Project Site plus an additional twelve inches of freeboard
- 18 inches

If AHJ has more stringent requirements, then AHJ requirements shall prevail.

Tracking systems (including trackers, PV modules, panel loading devices, and attachments) must be designed to withstand the Project Site climatic conditions described in Appendix 5.

Tracking system shall be installed per the manufacturer's instructions.

Tracking system shall be installed so all rows are properly aligned in accordance with manufacturer's requirements and alignment tolerances. Seller shall identify methodology being utilized to ensure alignment and document verifying compliance.

⁴ The defined term "tracker" contemplates a single axis tracking system.

⁵ NTD: Any limitation on the normal operation of the PV plant arising out of wind speed, snow load, or other climatic or environmental condition being above a certain threshold value applicable to the tracker must be properly incorporated into the inputs to and reflected in the outputs of the energy model. The loss of power generation or performance arising out of such limitation shall be based on the meteorological data provided in Appendix 5.

Solar BOT Scope Book

If applicable, power for the tracking system can be self-supplied or from solar PV array auxiliary power. Seller shall state the source of tracking power. For systems with onboard batteries, replacement frequency and associated O&M requirements shall be identified.

If applicable, Seller shall provide a controls narrative describing all active control functions and setpoints programmed into the tracking control system.

Dynamic modeling or wind tunnel tests can be used to determine the design lateral, vertical and dynamic loads. Any reduction in the loads stipulated in the codes due to such approach shall be kept within the limits established in the applicable standards. A written report describing the test(s), including the relevant conditions under which the test(s) were performed, and the test results shall be provided to Buyer promptly after the performance of the test(s). The conditions under which the test(s) were performed must be representative of the ones encountered at the Project Site. If wind tunnel tests are not performed as part of the Project, Seller shall provide Buyer recent wind tunnel test results previously conducted for the proposed trackers. Such review shall not alleviate or diminish Seller's responsibility to provide trackers that are suitable for the Project Site climatic conditions provided in Appendix 5.

Seller shall perform a load analysis and design the foundation type and embedment depth for the Trackers based upon, without limitation, the geotechnical and climatic conditions specific to the Project Site. If bored or rammed pile foundations are selected for the structure, Seller shall carry out a sufficient number of load tests in order to refine and/or validate the preliminary design before the Construction Commencement Date.

Seller shall confirm that the PV Module attachment methods are approved by the PV module manufacturer and are designed for the design loads expected to occur on the modules. The trackers shall incorporate integrated NEC/ and UL required grounding. The integrated grounding method shall be approved for use by the PV module manufacturer.

3.4.2.2 Structural Systems

All structural systems shall be in accordance with Appendix 5. Factors of safety for steel design shall be in accordance with AISC 360 and for foundation soil-structure interaction allowable strengths shall be per the local building code and IBC.

Structural steel – AISC 360. Torque tubes, Torque tube connection to foundations, and foundation piles shall be fabricated from steel designed per the AISC 360.

Black steel shall not be used for major structural elements of the tracking system. Refer to Section 3.2.9 for pile requirements and corrosion calculation requirements.

The trackers shall resist the wind loading without resulting in damage due to resonance or fatigue of the tracker proper and the modules. The tracking system shall be designed to address wind-induced dynamic resonance and torsional galloping. The Seller shall provide calculations from the tracker manufacturer showing the system is designed to avoid or accommodate the magnified loads due to the dynamic loads. This shall include specifically providing the following: mode shape frequencies of the tracker system (longitudinal, lateral, and torsionally along the torque tube), the damping characteristics of the system, and how the wind tunnel study provided recommendations on the magnitude of the dynamic loads that have been addressed. If the lowest natural torsional frequency of the tracker is less than 4 Hz, then the Seller shall provide additional analysis and calculations to the Buyer that demonstrates how the dynamic effects of the wind are mitigated and the risk for damage due to dynamic wind events are negligible.

The capacity of the bolts or clips used to attach the modules to the top of the tracker shall also be shown to withstand localized increased wind pressure effects due to wind on corners and edges of the tracker system as identified in the wind tunnel study.

Solar BOT Scope Book

3.4.2.3 Piles and Foundations

Black steel shall not be used for piles. Black steel shall not be used for major structural elements of the tracking system. Refer to Section 3.2.9 for pile requirements and corrosion calculation requirements.

Seller shall perform a load analysis and design the foundation type and embedment depth for the trackers based upon, without limitation, the geotechnical and climatic conditions specific to the Project Site. Seller shall conduct a pile pull test program, quantity of piles tested shall be selected in compliance with ANSI/ASQ Z1.4-2008 General Inspection Level II, AQL of .1 Pull Test results shall refine the foundation design recommendations by the Geotechnical Engineer of Record and incorporate these recommendations into the foundation design before the construction commencement date.

3.4.2.4 Clips and Module Attachment

Seller shall confirm the PV module attachment methods are approved by the PV module manufacturer.

The capacity of the bolts or clips used to attach the modules to the top of the tracker shall also be shown to withstand localized increased wind pressure effects due to wind on corners and edges of the tracker system as identified in the wind tunnel study.

PV module clips shall be designed to minimize the loosening of fasteners over time. Self-tapping screws shall not be used unless designed and documented for the Plant design life. Factory applied threadlocker or better (in terms of resistance to loosening from vibration) shall be used to prevent loosening.

PV module frames shall be bolted and secured in accordance with the module manufacturer installation guidelines. PV module frames shall be bolted in accordance with design windspeed using clamps that hold the modules individually or independently. Module "T" clamps or similar binders that depend on adjacent panels for tightness are permitted within a given module string only to minimize successive failure and each string must begin and end with an independent clamp design that isolates each string from the next. If such "T" clamps design is implemented, all strings must be capable of withstanding the Project Site climatic conditions as specified in Appendix 5 with an adjacent string or any string from a neighboring tracker and rack missing to ensure failure of a given string will not cause successive failures.

3.4.2.5 System Tracking and Stowing

The tracking system shall be able to track to a minimum +/- 52 degrees and accept alternative tracking limitations to accommodate weather conditions such as snow level, flood conditions, hail impact force reduction, and high winds. The tracker system shall have a backtracking (shade avoidance) feature to eliminate shading and maximize energy production.

The PV plant must include tracking systems that have the functionality to move the PV plant's solar arrays expeditiously to a stow or safe position in preparation for, or during unexpected, extreme weather events (for purpose of illustration only, hail, high wind, snow, and ice) to mitigate the potential adverse effects of such events on the PV plant. This functionality must be able to be provided:

- With power generated from a generating resource located on the Project Site
- Without causing Project components, systems, equipment, or items to become damaged or impaired during the transition to or from, or while in, a stow or safe position.

For a tracking system that relies on active measures to resist design basis wind loads, the system shall have a stow strategy that takes appropriate action in advance of the critical wind speed and be provided with a backup power supply to implement the stow strategy upon loss of primary power and/or communication of meteorological input data. Active stow system shall be designed to handle sustained critical wind speeds and have the ability to actively reposition throughout full range of travel during these sustained critical wind speeds, as required by the active stow system design and approach.

Solar BOT Scope Book

For a tracking system that utilizes passive stow system, the system shall be installed and tested per manufacturer's recommendations to ensure full functionality of system.

3.4.3 PCS

The PCS will be the integration of inverters, LV (auxiliary) and MV transformers, MV switchgear (if applicable), and auxiliary components such as the LV auxiliary panel, the communication system, and Local Control System (**LCS**) panel.

PCS shall be capable of complying with local utility ride-through settings as required.

PCS design shall verify equipment coordination to handle step-up/step down operation, static shield requirement between high side and low side, handling over-voltages up to 10% continuously, required winding impedance, suitability for operation with pulsed inverter and maximum voltage to ground as required, and efficiency meets or exceeds Department of Energy (**DOE**) targets. PCS output current harmonics shall contain <5% total harmonic distortion at rated power output.

PCS shall have the capability to accommodate the final installed DC capacity.

PCS shall be pad lockable.

3.4.3.1 Inverter step up transformer

Transformer shall be dead-front pad-mount, loop-fed and designed for inverter-based generation applications with continuous step-up operation. Transformer shall meet all requirements of the connected inverter including grounded electrostatic shield and pulse withstand if required by manufacturers.

Transformer shall be provided with primary overcurrent protection with partial range current limiting and Bayonet fuses at a minimum, under-oil surge arresters and equipped with under-oil, visible load break rated gang-operated disconnect switch, capable of keeping the loop closed while the transformer is de-energized.

Spill containment for Project transformers shall be as addressed in the Spill Prevention Control and Countermeasure (SPCC) Plan.

If oil cooled, transformers shall employ an environmentally friendly oil that has a higher flash point than regular oil (e.g., Cargill Envirotemp 360 fluid).

Step-up transformer shall have:

- High-side De-Energized Tap Changer (**DETC**) with 5 positions, nominal + two 2.5% adjustments +/-
- Specific test and ground points for commissioning and operations
- Visible NEMA rated ground connections

3.4.3.2 Inverters

Seller shall select a suitable technology to achieve the guaranteed PV plant capacity (and associated energy) level for the Project. The inverters selected by Seller shall have proven track records for performance, durability, and quality.

Inverters shall be selected and equipped to operate at rated capacity with respect to the local climatic and environmental conditions in Appendix 5. The inverters shall be designed, among other things, for reliability and to avoid significant power loss in case of failure.

Each inverter shall meet the following requirements:

- Designed in accordance with UL 1741 SA
- Includes an output AC circuit breaker or load interrupting disconnect switch

Solar BOT Scope Book

- DC inputs rated for continuous duty, including overcurrent protection devices
- DC inputs with ground fault protection, isolation monitoring, and instrumentation to measure current to an accuracy of 1% or lower
- Efficiency minimum of 97%
- Trip limits set per interconnecting utility, SCADA, and calculated system alarms and trips per design and inverter manufacturer recommended protection settings
- Capable of providing nighttime VAR support
- Equipped with communication capabilities and able to control the main parameters (DC power, AC power, and auxiliary consumptions at a minimum) from the LCS
- Allow remote operation utilizing read and write commands from the LCS and includes interface protocol support, an alarm and command points list, remote connection, operation, and linkage

3.4.3.3 AC Disconnect Switches

An AC disconnect switch shall be located within the inverter transformer. If installed externally and in addition to the AC disconnect switch associated with the inverter, AC disconnect switches shall be designed to provide a manual means of electronically isolating inverters allowing for disconnection of all three phases of output wiring from the inverter(s). AC switches shall be capable of breaking under full load.

3.4.3.4 Auxiliary transformers

Attributes of Project LV(Aux) Transformers shall include:

- Dry type transformers with minimum 7.5 kVA rating and 10 kVA 208/120 VAC rating
- Larger 3 winding transformers with minimum (25 kVA (or higher as needed) 480/277 VAC if needed for tracker)

3.4.4 Auxiliary Equipment and Systems

3.4.4.1 AC Auxiliary System

The LV electrical panel for indoor applications shall be a fixed, mounted design in accordance with NEC standards. For outdoor applications, the panel shall be NEMA 3R or greater.

3.4.5 SCADA

- Seller/Developer to design, supply, and install a redundant fiber-based network connecting all of the inverters, meteorological (**met**) stations, trackers, and step-up transformers
- Seller to design, supply, and install SCADA enclosures to integrate the inverters, met stations, and trackers
- Seller to develop communication system single line and network block diagram
- Seller to design, supply, and install Collector Substation Control House communication rack layout, including BOM and elevation drawings. All projects to have redundant SCADA system with primary and secondary switches and connections on both PV and collector substation.
- Seller to design, supply, and install appropriate SCADA, communications, wiring, fiber, splice details
- Seller to design, supply, and install field installed SCADA communication panels at each inverter with layer 2,3 looped switch and fiber patch panel in a National Electrical Manufacturers Association (**NEMA**) 4X enclosure
- Seller supplies Seller controlled fiber to the site (i.e., ATT fiber which the Seller is the account Buyer of) – this is to support Commissioning activities
- All fiber optic cable shall be 96-strand, single mode, meeting Telecommunications Industry Association (**TIA**) 568.3-E

Solar BOT Scope Book Main Body

Solar BOT Scope Book

- This site will have an additional fiber for the Entergy network from the interconnecting substation to the Collector Substation
 - If the distance from the Entergy substation to the Collector Substation is cost effectively short and Entergy owns the property rights, then: (refer to Figure 3)
 - Underground the fiber
 - Buyer supplied fiberoptic cable shall be underground rated
 - ADSS fiber to be pulled in microduct/conduit
 - Demarcation point between Seller/Developer installed microduct/conduit from Collector Substation and Entergy’s installed innerduct/conduit is a Seller installed pull box or similar at a mutually agreed to point, typically at or the near the property boundary, between the interconnect substation and Collector Substation (often initially marked as a stake in the ground) – refer to Figure 3
 - Innerduct/Conduit shall be conduit or microduct (e.g., 2 inch PEX) with a minimum 2 inch diameter and 36 inch bend radius
 - Seller to install lightbox and 100 ft slack spool and associated innerduct/conduit in the Collector Substation
 - Buyer/Entergy will supply and terminate fiber on both ends

Figure 3: SCADA connection-all underground

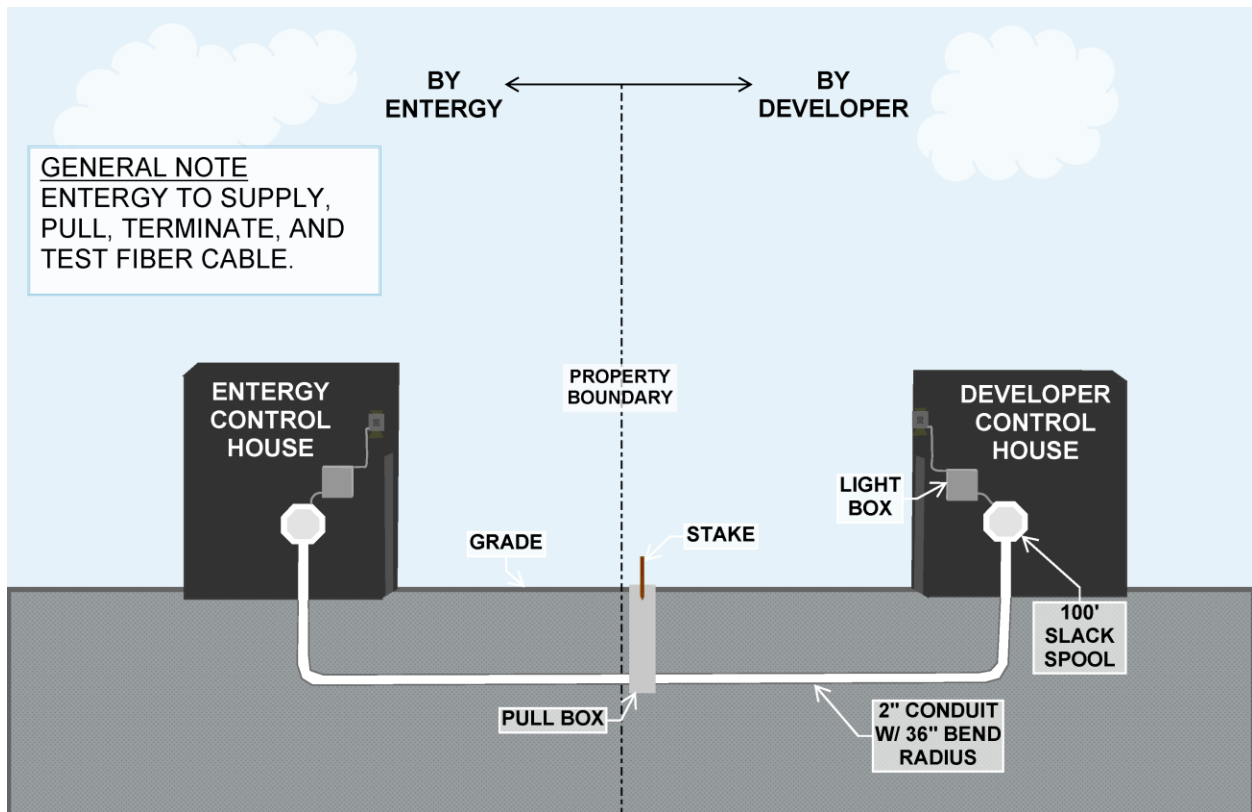

- If the distance from the Buyer/Entergy substation to the Collector Substation is not cost effective for underground fiber or if Entergy does not own property rights, then (refer to Figure 4):

Solar BOT Scope Book

- Seller/Developer to install 96-strand OPGW fiber and associated fiber splice box on pole to transition to underground to the collector substation, including all fiber fusions in the splice box as required
- Seller furnished fiberoptic cable shall be underground rated (from existing control house to dead end pole)
- Seller fiber shall OTDR reel test at 1550 nm and results provided to Entergy in “.SOR” format
- OPGW fiber shall be installed at a height >15 foot on structures
- At all splice locations, a 100 foot plus height above ground level reel of fiber shall be installed on a Seller supplied and installed coil bracket
- Between the final structure and the Collector Substation Control House lightbox, Seller to supply and install innerduct/conduit and associated ADSS fiber
- Seller to terminate ADSS fiber with Collector Substation Control House
- Seller to leave 100 foot of fiber and slack spool on a Developer supplied and installed coil bracket within the Control House
- Microduct/Schedule 40 PVC conduit with a minimum 2 inch diameter with 36 inch bend radius
- For purpose of developing a project, the Seller can assume the following:
 - Demarcation point between Developer/Seller installed Innerduct/conduit from the first structure and Buyer’s installed innerduct/conduit is a Seller installed pull box or similar at a mutually agreed to point, typically at or the near the property boundary, between the interconnect substation and first structure Collector Substation (often initially marked as a stake in the ground)
 - Seller to supply and install a splice box on the first structure
 - Entergy will supply and terminate fiber on both ends
 - Entergy to perform OTDR on all splices with no losses greater than 0.10 dB allowed

Solar BOT Scope Book

Figure 4: SCADA connection-some aboveground

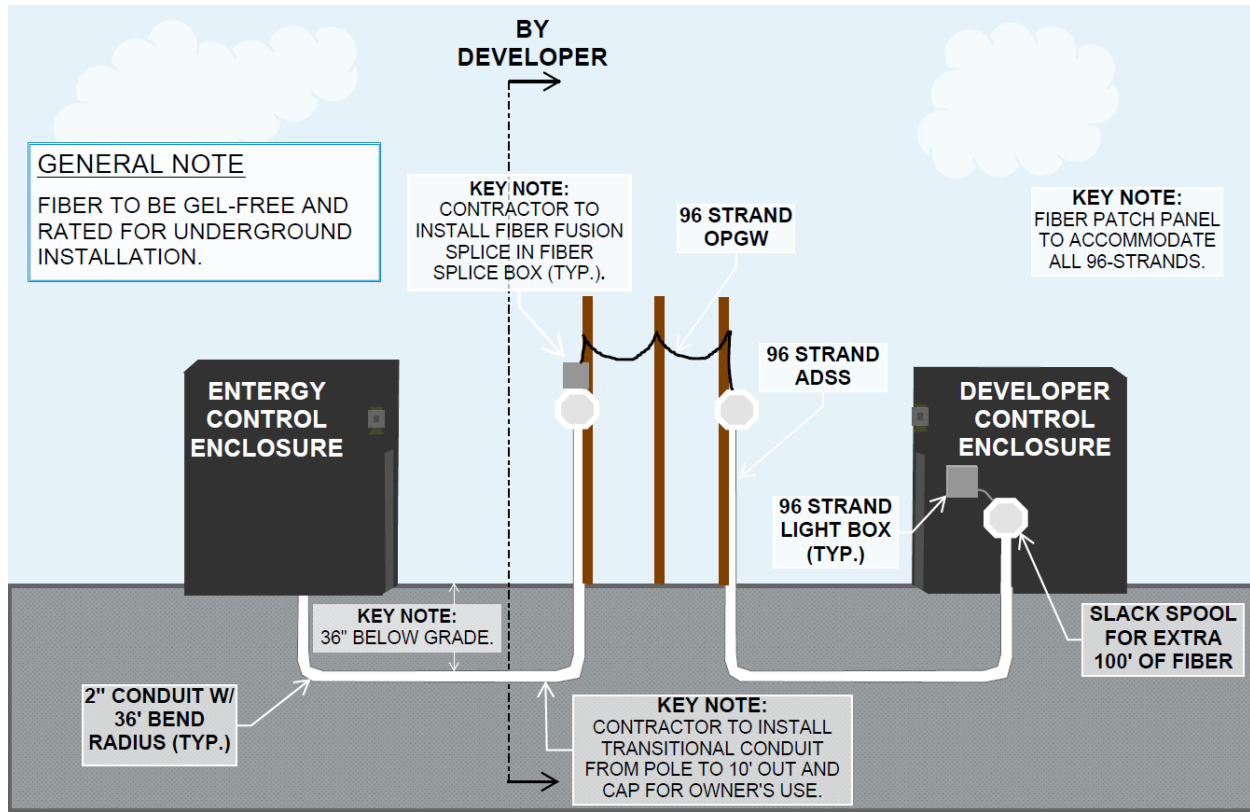

- Seller to land the Seller controlled fiber (i.e., ATT) on a Seller supplied and installed firewall (Palo Alto or CheckPoint are acceptable firewalls)
 - Seller to supply and install a firewall managed Level II switch with 3 VLANs configured (Seller to supply subnet information)
 - The 3 VLANs consist of the following
 - Collector Substation
 - PV Yard
 - Control
 - Seller to work with Entergy's Information Technology group in configuring the firewall using allow by exemption principle and opening only ports and protocols necessary for required functionality
 - Configure VLAN Access Control Lists to manage routing for only necessary functions
- Seller to supply and install redundant core switches (IE4010 switch or similar) and connect to upstream SM SFPs
- Seller to supply and install fiber patch panels
- Seller to supply and install 42U server rack
- Seller to supply and install 8hr UPS
- Seller to supply and install miscellaneous fiber, ethernet jumpers, and cable management
- For purposes of design, assume that the site will be a CIP Low site
- Seller shall configure the SCADA system for access credentials including Admin, Operator, and View Only credentials; SCADA shall be View Only upon launch with credentials required for operational changes

Solar BOT Scope Book

- Seller supplies and configures a Power Plant Controller
 - The Power Plant Controller can be two SEL 3555 – RTACs in redundant configuration or similar
 - Power Plant Controller shall be configured with the with the following Control Aspects
 - Control Modes
 - Voltage
 - VAR
 - Power Factor
 - Setpoint Control
 - Local
 - Remote – Automatic Generation Control
 - A narrative of the control configuration shall be supplied
- Seller shall supply and configure Ignition as the plant's SCADA system
 - Seller to supply and install redundant Type I virtualized servers hosting the Ignition (DEL PowerEdge Rackmount server or equivalent)
 - Each Type I server shall be sized (hard drive, memory, etc.) to allow both Ignition servers to be running in either location if needed.
 - Seller to supply and install one KVM switch with 19-inch display, keyboard, mouse
 - Ignition shall be supplied with Historian and unlimited tag licenses
 - Historian shall be sized for 2 weeks of 1 second data
 - Seller shall supply and install one Inductive Automation Ignition HMI package
 - Seller shall supply and install one SQL server license (or equivalent)
 - Seller to configure web portal access
 - Within Ignition, the Seller shall buildout the Graphical interface to include the following screens at a minimum:
 - Site overview
 - Control
 - Alarm management
 - Trending management
 - Inverters details
 - Tracker details
 - MET details
 - SCADA health (i.e., communication detail)
 - One-Line (to include Meter details and all other high level RTU-RTU datapoints)
 - Reporting Functions
 - Install Ignition utilizing least functionality privilege and operating system utilizing CIS Benchmark
 - Seller to work with Buyer to define Ignition security user groups credentials including Admin, Operator, and View Only credentials; Ignition shall be View Only upon launch with credentials required for operational changes
 - Within Ignition, seller to configure the object alarm configuration based on the I/O List
- Seller to configure Major Interfaces including the following
 - PI
 - RTU-RTU (Collector Substation to interconnecting Entergy Substation) - Seller to provide Entergy the following Point List
 - Overall Point List
 - Abbreviated Point List focused on Seller's typical importance list
- Seller supplies and installs an IT rack for Entergy's exclusive use in the Collector Substation
 - 19-inch rack with 24-inch x 36 inch footprint
 - Front and back lockable mesh doors and cable entry slots in roof
 - 36-inch front clearance and 24" rear clearance

Solar BOT Scope Book

- Dual 120 V_{ac} UPS backed power strip with UPS ethernet monitoring capability, with UPS capable of 12 hours of backup run-time
- At Substantial Completion
 - Seller to transfer all licenses procured on Entergy's behalf to Entergy
 - During license procurement, Seller shall work with Entergy in establishing Terms and Conditions which will allow for seamless transfer
 - Seller and its subsidiaries shall surrender all rights to software development work for this project to Entergy for use within this site at a minimum.
 - Seller transfers Seller owned fiber account ownership to ETR (we take over ATT account)
 - ETR installs and interconnects Firewall (between ETR network fiber and the site's Seller supplied Palo Alto/CheckPoint firewall)
 - Seller to develop and supply system documentation consisting of the following
 - Hardware/software manuals
 - Server setup and configuration details
 - All username and passwords
 - Drawings list and specifications
 - Testing and commission documentation
 - Tag list with tag name, units, description, and range as a minimum

3.5 Control System and Communication Requirements

3.5.1 Control System Security

3.5.1.1 Cyber Security

Seller shall design, build, and deliver a cyber security system and plan for the Project that conforms to applicable NERC CIP rules, regulations, standards, and Laws. Buyer shall provide Security controls that will be required to be tested prior to site acceptance. If Seller becomes the site operator, there will be shared responsibility between the construction and operator divisions agreed to by all parties. Seller shall develop and provide to Buyer a cybersecurity plan that includes accommodations to test the defined security controls. (Buyer may elect in its discretion to provide a sample plan for Seller to consider and possibly utilize.) The plan must include and cover:

- Steps taken in software development to detect and correct security flaws, including plans for code scanning
- Methods used to protect system user identities and logins, including methods of encryptions and use of certificates
- Methods to assure reliable and confidential communications of inbound commands and outbound data.
- A description of software maintenance processes, including the process to patch security vulnerabilities in the vendor's product
- Test planning to assure compliance with the cybersecurity plan

Seller shall implement cybersecurity controls for low impact and non-CIP solar sites testing NERC CIP in development of cyber security plan. Buyer expects to provide additional guidance or input in the development of the plan to ensure the Project's cyber systems are compatible with and provide the protection required or appropriate for Buyer's cyber systems. The plan is subject to Buyer's review and approval in advance of the FNTF date.

Buyer will contract for a third-party vulnerability assessment and penetration test during Project testing. Such testing shall be done, at Seller's expense, as a "type" test for the initial unit, with testing not required for subsequent units. Seller shall correct vulnerabilities identified in this testing and the completion of such corrections shall be a condition to substantial completion.

Solar BOT Scope Book

Seller shall:

- Undertake periodic reviews of emerging vulnerabilities that will potentially impact the Project.
- Provide notice to Buyer of new vulnerabilities within a specified time frame from a new vulnerability becomes known.
- Develop corrections (patches) to address identified vulnerabilities.

Seller shall assure the above software support, including operations and maintenance, is provided through Substantial Completion. Buyer reserves the right to perform periodically independent, recurring security audits to assure compliance with the security maintenance requirements of this Scope Book during the performance of the Work.

Once the Project's cyber security system is in operation, Seller shall not provide communications directly to the system and must access the system via Buyer security controls. If Seller reasonably requires monitoring (read-only) information to perform the Work, Buyer will use commercially reasonable efforts to provide such information via internet solutions to Seller or the applicable vendor after Seller's request therefor. Any remote access to the cyber security system shall be covered in the cyber security plan, and Buyer agrees to use commercially reasonable efforts to cooperate with Seller to provide mutually agreeable solutions for gaining access to the system once in operation.

3.6 Met Station

Subject to other terms hereof, Seller shall provide a minimum of two met stations for the Project and a Soiling Measurement Station (**SMS**). One main met station shall be located near the Project Site control building. The stations shall be arranged to allow for the determination of and provide an accurate weather profile for the overall solar field and the Project.

Met stations shall be compliant with the International Electrotechnical Commission (**IEC**) 61724-1:2021 (Photovoltaic System Performance – Part 1: Monitoring). Class A table requirements shall be used.

The number of met stations shall be compliant with IEC 61724 – Part 1, Table 3.

Met stations shall be provided with NEMA 3R or greater enclosures. Instruments and sensors associated with the met stations shall be calibrated by a reputable, certified laboratory. Refer to Table 2 and 3 of IEC 61724 for the number of stations required.

The main met station shall contain or meet, among other things, the following requirements as a minimum:

- Two (2) module backed Resistance Temperature Detectors (**RTDs**) (per met station) to be mounted on production racking within 150 feet (45 meters) of met station and at least 50 feet (15 meters) from each other
- Three (3) platinum resistance temperature detector (RTD) sensors with a range of -40 °C to +70 °C and an accuracy of +/-0.5 °C, installed as per IEC 61724 and manufacturer recommendations
- One (1) SMS (strategically located to capture any expected differences in soiling rates across the site) per 100 MWac
- One (1) barometer

Flood sensors shall be provided for all areas of solar array installed within a floodplain or where site drainage characteristics may introduce localized ponding to depths that reduce the lower module edge clearance above flood inundation and drainage ponding levels to less than 12 inches (30 centimeters) [Note: quantity of flood sensors shall be determined by Seller but shall be sufficient to protect affected modules within independent flood and ponding zones independently of strings outside of these zones and allowed by tracker or rack grouping]

Solar BOT Scope Book

A data logger for local data saving and for remote data transfer through available telecommunication infrastructure; the data logger shall be capable of accommodating all sensors and be protected against direct sunlight; irradiation data should be collected every second and stored as ten (10) min averages (in W/m²) and as the sum total for any defined time period (in Wh/m²)

Minimum twelve (12) hour backup battery.

The additional met stations, as prescribed by the standard, shall meet the following requirements:

Similar equipment manufacturers as in the primary met station

Compliance with IEC 61724-1:2021

The met stations shall be powered either by:

- PV modules and batteries (sizing of the system shall ensure complete autonomy throughout the year and avoidance of power shortage)
- Direct LV connection to the nearest building or inverter and transformer block. Seller shall design a backup system to ensure a minimum of three (3) days of autonomy to the Project in case of a grid failure.

Data can be directly transferred to the unit or block equipped with communication capacities and available in the monitoring system.

Batteries and all electronics shall be installed in a protected area away from direct heat and protected against the elements by a sunshade.

See Appendix 1- Collector Substation.

3.7 Metering Requirements

Project shall include a revenue grade meter(s) for performance and capacity testing.

See Appendix 1- Collector Substation.

3.8 Interconnection of Utilities

Seller shall provide all utility interconnections needed for construction, commissioning, and testing of the Project or performance of the Work in each case or any portion thereof (e.g., potable and non-potable water, wastewater, sanitation (including sewage), temporary power, telecommunications, broadband internet, and fuel).

3.8.1 Data Network Engineering and Data Network Operations (DNE/DNO)

3.8.1.1 DNE Design

Buyer will provide to Seller the DNE design including address space of the affected zones. Zones to include the collector substation, PV yard, physical security (CCTV and ACCESS control), and Entergy corporate network. The DNE design will provide flexibility for future of division of responsibility for operations.

Allocation of devices in defined address space will be left up to respective party's network address space of networks will be provided by Entergy DNE and filtered by Entergy onsite firewall to ensure separation of separately managed network and in compliance with applicable Buyer and regulatory requirements.

Seller is responsible for ensuring address space provided by Buyer is adequate to support devices being installed and configured by Seller. Seller shall install Cisco network devices unless otherwise approved by Buyer.

Solar BOT Scope Book Main Body

Solar BOT Scope Book

Seller's design shall be subject to Buyer approval at Buyer's sole discretion.

Seller shall provide redundant Layer 2 network switches. Network segmentation of Seller-provided network shall meet the following requirements:

- Collector substation equipment (RTU, breaker relays, etc.) shall be on its own VLAN segment
- PV yard equipment (Inverters, Metrology, PPC, etc.) shall be on its own VLAN segment
- PV access control and camera system shall be on its own VLAN segment
- Prior to substantial completion, segments shall be filtered by a Seller-provided firewall. Logical segments shall be filtered by a Buyer onsite firewall after substantial completion Seller shall provide to Buyer reasonable and necessary requirements for firewall configuration between segments
- Prior to substantial completion, network connectivity shall be provided by Seller. After substantial completion, network connectivity shall be provided by Buyer
- Seller to use defined cable and connectors. User-defined color codes for low CIP sites are as follows: primary ethernet shall be blue, secondary ethernet shall be gray, back-up ethernet shall be green, iLO/KVM shall be yellow, and serial consoles shall be black

3.8.1.2 Procurement and Ownership

Seller shall procure equipment with a minimum five-year manufacturing and support warranty with service level agreement of next day replacement.

Any items that will reside on the Buyer's network (e.g., CCTV, firewall, access control), Buyer will be responsible for procuring, installing, operating, maintaining, and managing. Special cases may be considered but are subject to strict review of cyber asset protection and monitoring. As such a third-party operation of a facility may be allowed to purchase, configure, install, and maintain network equipment if the equipment will be protected or isolated from the Entergy network via firewall apparatus or diode and the third party will be establishing means to replace failed equipment through a five-year period of operation.

3.8.2 Desktop Equipment

As required by Buyer for the functionality of the site and in support of Entergy associates or vendors onsite, Buyer will specify desktop equipment to be utilized. Seller shall install fixtures and wiring terminated on appropriate breaker or patch panels to allow Entergy field services to install and configure equipment. Desktop equipment includes laptops, desktop computing boxes, printers, and peripheral devices.

3.9 Physical Security Installations

The physical security of the site shall comply with Buyer and regulatory requirements. Seller is responsible to implement as described in Table 5 below and the following sections.

Solar BOT Scope Book

Table 5: Physical security installation requirements

Location	Description	Equipment by Seller	Equipment by Buyer
Motor Operated Sliding Gates	Electrically operated slide gate with keycard reader	Keypad, slide gate, gate operator, wiring (power and communications), grounding loop, exit button and hardware for mounting keycard reader	Keycard reader

3.9.1.1 CCTV Installations

Seller shall supply the Network Video Recorder (**NVR**), Genetec Streamvault SVR-500A or approved equal, and pan, tilt, zoom cameras for the project site.

Seller-supplied cabling for all cameras at the Project Site will be copper or fiber traveling and connect to identified network switches supplied by Buyer. A Seller-supplied uplink cable will connect the NVR to the Buyer's network switch.

The location of NVR equipment shall be monitored by an installed camera.

Seller shall design the system so all cameras to be mounted at the Project Site will be mounted within a physically secure area within or enclosed by fencing installed and will have an unobstructed line of sight and the ability to obtain and record reasonably clear images, at minimum, at and around each location to be covered by the camera. The design and installation of the system will include proper conduit, ethernet, and fiber and will have appropriately placed and connected power outlets and power supply for Buyer to contract and install. Wireless equipment is not allowed.

Seller shall use the following camera design criteria for camera mounting locations:

- Exterior open space cameras shall support panoramic with pan, tilt, and zoom attachment below
- Interior cameras focused on doors shall be fixed dome providing a double-ganged, ceiling-mounted junction box
- Exterior cameras focused on doors shall support panoramic, fixed dome, or fixed bullet style providing a double-ganged, ceiling-mounted junction box

Locations to be recorded:

- CCTV installation site
- All gates and any other point of ingress and/or egress at the Project Site with coverage and clarity sufficient to identify any representative of the parties and their respective contractors and subcontractors and any other person and markings and license plates of any vehicle entering the Project Site through the gates.
- Either side of any human passable door into or inside any building that includes such doors, including the control house

3.10 Locks

The site will be a mix of Buyers access control system for control houses and battery storage. All equipment shall be lockable per NERC/CIP requirements. Seller responsible for project until COD. Buyer will supply its own locks at COD.

Solar BOT Scope Book

All egress and ingress doors on building not on access control system shall utilize keyed high security puck lock or a high security cylinder lock that will not delay occupant egress.

All NEMA equipment enclosures shall utilize a high security padlock or a clasp lock for the following use equipment types:

- IT
- Telecom
- Inverter
- Met stations

Seller shall coordinate with Entergy Security to intake and begin management of CyberLock equipment using the CyberLock system managed by Buyer.

3.11 High Security Chain

Seller shall provide high security chains on appropriate gates or other site access points. The chain will be 0.375-inch minimum, heavy-duty construction rated either “high security” or grade 100 or higher with a through-tempered alloy and square-sided construction to minimize cutting ability.

3.12 Lock Forms

The acceptable types of locks Seller shall provide at the Project Site are:

- High Security Padlock – A padlock that meets certain levels, a minimum grade of F5/S6/K5/C4 per ASTM F883-13 in each of the areas of concern is desired
- High Security Puck Lock – A padlock in the form of a hockey puck with the shackle hidden in a recess on the back side. This type of lock provides its high security by protecting the shackle itself from access, uses the same high security key as the padlock, and includes a special hasp that has a surround shield protecting the hasp tab and hole from cutting where the shackle enters the padlock
- Clasp Lock or Cam lock that fits NEMA cabinets as required

4 Energy Model and Energy Yield Verification

Any Energy Model for the Project provided to Buyer after the effective date shall be compliant and function in accordance with the terms of this Agreement.

The Energy Model requires a PVsyst software program and PVsyst input files to run the PVsyst simulation in the Energy Model. The version of the PVsyst software program for the Energy Model shall be as specified in item 3.5 of Appendix 4 to this Scope Book. The PVsyst input files for the Energy Model shall consist of .PAN, .OND, .PRJ, .VC#, and .MET files.⁶

The Energy Model also requires inputs and assumptions to generate projections of PV plant output. These inputs and assumptions are based on or include discrete design parameters, physical characteristics, equipment capabilities, and similar attributes of the Project, Project layout and location, relevant meteorological and environmental conditions, and other factors. The inputs and assumptions shall be developed and mutually agreed to between parties for the effective date Energy Model and shall

⁶ NTD: Depending on the Energy Model used and accepted as the Effective Date Energy Model, .SIT, .SHD, and/or .HOR files could also be included.

Solar BOT Scope Book

be reflected in the in the Final Agreement. Appendix 4 and, to the extent applicable, Appendix 3 to this Scope Book set forth certain inputs for the PV plant used in the effective date Energy Model. The inputs to the effective date Energy Model are based on or derived from the proposal submitted in the RFP that led to the Agreement.

In addition, the Energy Model requires the application of losses (post-process losses) not captured by the underlying PVsyst model. Such losses shall be presented and modeled as a singular loss value shown in Appendix 4. The inputs and assumptions for such losses in the effective date Energy Model are based on assumed values and reflected in the documentation included in the Agreement.

The effective date Energy Model shall establish and be considered the final form of the Energy Model. The effective date Energy Model version of the PVsyst program, the types and versions of the PVsyst program files, the types of inputs and assumptions used in the PVsyst program input files, the types of post-process loss adjustments, and the form of the Energy Model report created after a run of the PVsyst program shall not be changed after the effective date without Buyer's prior approval, which may be provided in Buyer's sole and absolute discretion. Subject to the remainder of this paragraph, the inputs and assumptions to the Energy Model shall be updated after the effective date to cause the Energy Model to correctly reflect the Project design and/or physical attributes or characteristics of the Project as of 100% Project design completion or substantial completion. Appendix 4 and, to the extent applicable, Appendices 3 and 4 identify which of the characteristics listed therein are subject to limitations that restrict Seller's ability when designing, procuring items for, or building the Project to deviate from the value or data entry for a particular characteristic specified for the Project in the applicable Appendix. Other provisions of the Scope Book or the Agreement may include similar restrictions. Seller is not authorized to update any input or assumption used in the effective date Energy Model to the extent the updated input or assumption fails to comply with the limitations or requirements of this Scope Book or the Agreement applicable to such input or assumption. Permitted updates to the inputs or assumptions used in the Energy Model could include, for example, changes reflecting certain supplier data obtained after final equipment selection and overall refinements to the physical PV plant during the design phase that do not deviate from the basic design of the Project and that Seller is permitted to make under the terms of the Agreement. For the avoidance of doubt, the inputs and assumptions used in the .MET input file for the Energy Model shall be final as of the effective date and may not be updated or otherwise changed.

The Energy Model shall be rerun on each of the following dates (each, an Energy Model Delivery Date):

- On or before 10 days after the delivery by Seller to Buyer of written notice that the IFC design package prepared following 100% completion of the detailed design of the Project (see Section 2.2 above) (the Design Completion Energy Model)
- On or before the delivery by Seller to Buyer of the substantial completion certificate (reflecting the Project as then built and tested) pursuant to the Agreement (the Substantial Completion Energy Model).

Seller shall maintain an up-to-date, accurate log recording the date and basis for and a reasonable description of each change, if any, to the Energy Model from the effective date through the substantial completion payment date, including changes to any input or assumption used in the Energy Model. Seller also shall provide the then-current log of all such changes (and associated documentation reasonably requested by Buyer) to Buyer upon Buyer's request or at intervals or times as the Parties may otherwise agree. Such log may include versions of Appendices 2, 3, and 4 that have been updated in accordance with, and subject to the limitations set forth, herein and therein. Seller shall notify Buyer in writing reasonably in advance of any running of the Energy Model and consider in good faith any Buyer comments made to Seller regarding the Energy Model, including any objections to inputs or assumptions proposed to be used in the Energy Model.

The Energy Model shall be prepared and run by (the Project Performance Test Contractor), and the Energy Model report (along with the associated Energy Model files, inputs, assumptions, and documentation, including any supporting calculations prepared by the Project Performance Test Contractor) shall be provided to Buyer within one day after completion of each required model run

Solar BOT Scope Book Main Body

Solar BOT Scope Book

specified above. For an Energy Model to be final and the results thereof given effect, the associated test report (including the contents thereof) must be completed in accordance with the requirements of this Scope Book and be free from any errors, omissions, or other defects.

The parties agree the effective date Energy Model establishes the expected energy yield for the PV portion of the Project as of the effective date (specified in Appendix 3) as the Project's "Base Case Expected Energy Yield." Seller guarantees the expected energy yield in each subsequent Energy Model delivered to Buyer under this Scope Book will equal or exceed the Base Case Expected Energy Yield or the "Energy Yield Guaranty". If the design completion Energy Model does not demonstrate the Energy Yield Guaranty has been satisfied, Seller shall undertake to diagnose and cure the cause(s) of the Energy Yield Guaranty deficiency, which cure could include Seller making permitted modifications to the Project design to ensure the Energy Yield Guaranty will be satisfied at substantial completion. Seller shall update the inputs and assumptions to and re-run the Energy Model, in accordance with and subject to the terms of this Scope Book, after completion of such cure until the Energy Yield Guaranty has been satisfied. If the substantial completion Energy Model does not demonstrate the Energy Yield Guaranty has been satisfied, Seller has two options:

- Cure the cause(s) of the Energy Yield Guaranty deficiency. The cure could include Seller making permitted modifications to the Project, updating the inputs and assumptions to, and re-running the Energy Model in accordance with and subject to the terms of this Scope Book until the Energy Yield Guaranty has been satisfied.
- Pay Energy Yield Liquidated Damages in accordance with the Agreement.

5 Commissioning and Testing

Seller shall develop a commissioning plan and process (Commissioning Plan) that ensures all Project components meet the requirements of the Agreement, this Scope Book. The Commissioning Plan shall conform to and include, without limitation, the components set out in Appendix 7, Project Performance Test Procedures. The Commissioning Plan shall outline the tasks, processes, procedures, and deliverables required to commission the Project, conduct the performance tests, and prove the function and performance of the Project, including its components. The Commissioning Plan shall designate the tests and processes required to be completed and performed prior to mechanical completion and substantial completion in accordance with the Agreement, including completion of all QA/QC tests prior to mechanical completion and completion of all project performance tests prior to substantial completion. Seller shall perform a random pile and pull testing campaign in accordance with ISO-2859-1, subject to general inspection level II, and an acceptance quality limit of 0.10.

Seller shall provide the Commissioning Plan to Buyer reasonably prior to the commencement of Seller's commissioning activities. Buyer shall provide comments, if any, in good faith on such Commissioning Plan to Seller within 10 business days after Buyer's receipt of such Commissioning Plan. If Buyer provides such comments, Seller, within five business days after Seller's receipt of Buyer's comments, shall revise the Commissioning Plan to address Buyer's comments and resubmit the revised Commissioning Plan to Buyer for review and approval. This procedure shall be repeated until the Commissioning Plan as modified is approved by Buyer. Buyer shall promptly notify Seller in writing if and when it has approved the Commissioning Plan.

Buyer shall be given reasonable advance notice of and a reasonable opportunity to review, monitor, and witness all commissioning and testing activities performed as part of the Work. Seller shall provide Buyer a schedule of all factory and Project Site tests, inspections, and performance tests within thirty (30) days after the FNTF date and any update to such schedule promptly after such update is made.

Buyer and its contractors and representatives shall be permitted access to the Project Site at all times and shall be permitted to visit factories during the manufacturing of equipment, materials, and

Solar BOT Scope Book

components for the Project and to witness factory tests and inspections. Buyer may contract with one or more third parties to conduct individual inspections and tests at any time to confirm test results and to verify the Project has been installed and constructed in accordance with the requirements of the Agreement and this Scope Book.

Where manufacturing or finishing is performed at the Project Site, reviews, inspections, studies, and tests shall be conducted as a replacement for an appropriate workshop test. The preliminary check-out and test runs, the reliability test run, and the project performance tests shall be carried out by Seller under the witnessing of and review by Buyer and its contractors and representatives.

These tests shall demonstrate among other things:

- Completeness of the mechanical and electrical construction works
- Correctness of the assembly and installation
- Safety and reliability of the Project under all operating conditions
- Proper functioning of the components and system under all operating conditions.

5.1 Commissioning Documentation and NERC Compliance

The minimum required information for commissioning shall be documented and checked, if appropriate, during the commissioning period, including:

- Basic system information
- Project location and installation date
- Rated system capacity (DC and AC)
- PV modules and inverter – manufacturer, model, and quantity
- Commissioning date
- System designers' information
- System installer and contractor information
- Detailed single-line diagram of the Project
- Array general specifications
- PV module type
- PV module number
- Number of PV modules per string
- Number of strings
- PV string information
- String cable type, size, and length
- Specification (current and voltage rating) of overvoltage protection device
- Array electrical characteristics
- Array junction box location
- Array main cable specification
- Location, type, and rating of over voltage protective devices
- Earthing and over-voltage protections
- Single-line diagram(s) showing the details of all earthing, lightning protection, and surge protection systems
- A single-line diagram showing AC isolator location, type, and rating and similar information for AC over-current protection device
- Technical data sheet for all major components
- Warranty documentations for PV modules and PCSs with the information of starting date of warranty and period of warranty
- Mechanical design information and data sheet of array mounting structure (static report)
- Documentation of all required permits
- Documentation and stock of spare parts and consumables

Solar BOT Scope Book Main Body

Solar BOT Scope Book

- Documentation of PV module flash test data
- Commissioning test reports
- Equipment calibration certificates
- Operation and maintenance information, including:
 - Procedures for verifying correct system operation and minimum guaranteed performance parameters
 - Preventive and corrective maintenance procedures
 - Scheduling of routine maintenance
 - A checklist of what to do in case of system failure
 - Emergency shutdown and isolation procedures

Seller shall be compliant with the applicable NERC reliability standards in effect as of the Effective Date including those set forth in Appendix 10 to the Scope Book. Seller shall be responsible for the Project complying with all Generator Owner (**GO**) and Generator Operator (**GOP**) obligations in Appendix 10 through Substantial Completion.

Seller shall provide to Buyer reasonable evidence of Seller's compliance with the NERC Standards and any other NERC-related documentation reasonably requested by Buyer or required by NERC as requested by the due dates listed in Appendix 10.

5.2 Factory Acceptance Tests

All equipment, materials, and components noted below shall be factory tested to ensure such items are suitable for use at the Project and will be able to satisfy the requirements of the Agreement, including this Scope Book. Quality check lists and test protocols for such equipment, materials, and individual components shall be submitted by Seller prior to and during the factory tests.

Seller should expect Buyer to attend the inspections of at least the following equipment:

- PV modules
- Inverters and PCS
- Trackers
- Step-up transformers
- Inverter power transformers
- HV switchgear, if applicable
- MV switchgear
- LCS
- First install / "golden row"

Other equipment, materials, and components shall be "routine" or "type"-tested in the factory in accordance with the applicable standards set forth in Section 1.3 of this Scope Book. The items to be tested and frequency of testing shall be as agreed between Seller and Buyer prior to the FNTF date. Type tests shall not be repeated if type test certificates of identical equipment designed and fabricated to a specification identical to that of the Project are available. Any proposed type test certificates must be submitted to Buyer for review and approval.

The following sequence shall be included in Seller's QA/QC Plan provided as part of the PEP:

- Seller shall keep a three-month look ahead inspection schedule, which shall be updated on a regular basis as part of the monthly progress report
- Seller shall provide Buyer notice of its intent to inspect prior to any inspection as detailed in the Agreement
- Prior to notifying Buyer of its intent to inspect, Seller shall have issued and obtained Buyer's approval of the relevant inspection test plan and all other technical documentation relevant to the inspection

Solar BOT Scope Book

- Buyer will notify Seller of Buyer's intent to attend the inspection. Buyer may contract with third-party inspectors to attend the inspection with or on behalf of Buyer
- Upon completion of the inspection, Seller shall issue an inspection test report summarizing the results of the inspection, including any reports generated by the manufacturer, for review and approval by Buyer.

5.3 Project Performance Tests

Seller shall conduct all project performance tests after the closing and synchronization of the Project to the interconnected electric grid. Project performance tests may be run simultaneously when possible.

Appendix 7 sets forth certain requirements, standards, and procedures for the performance of the project performance tests, which shall be conducted in accordance with the Commissioning Plan under Section 5 of this Scope Book.

The Project Performance Test Report shall include the following information with respect to the project performance test:

- Summary
- Test Protocols
- Instrument Calibration Certificates
- Test data (manual and data acquisition)
- Field Notes
- Calculations
- Conclusions

5.3.1 PV Plant Capacity Test

Seller shall cause a Project Performance Test to be performed to determine PV Plant Capacity in accordance with the requirements, standards, and procedures set forth in Appendix 7. The PV plant capacity shall be measured at the electrical interconnection point.

The project performance test conducted to determine the PV Plant Capacity may not be interrupted or suspended and then resumed without Buyer's prior written approval. The PV plant must have operated and performed as designed (and must have achieved the minimum PV plant availability) during such project performance test for such project performance test to be considered valid for purposes of determining the PV plant capacity.

5.3.2 PV Plant Availability Test

Seller shall cause a project performance test to be performed to measure PV Plant availability in accordance with the requirements, standards, and procedures set forth in Appendix 7 of this Scope Book.

The project performance test conducted to determine the PV plant availability may not be interrupted or suspended and then resumed without Buyer's prior written approval.

5.4 Equipment Warranties

Seller shall notify Buyer of any procedure, activity, or other Work that may void a manufacturer warranty or violate any law or applicable permit reasonably in advance of the performance of such procedure, activity, or Work. Seller shall provide to Buyer all original equipment manufacturer warranty documents. Refer to Table 6 for warranty requirements.

The original equipment manufacturer's warranty shall cover the equipment is free from defects in material, manufacture, workmanship, and design. In the event of a breach of the warranty, the PV module

Solar BOT Scope Book

manufacturer shall take corrective action at its cost to repair or replace and prevent in subsequent years breaches warranty.

Table 6: Table of Warranties

Equipment	Warranty Type		Comment
	Workmanship	Performance	
Solar Module	10 years	25 years	The original equipment manufacturer warranties for the PV modules shall cover the following that may commence no sooner than the earlier of <ul style="list-style-type: none"> • The date of completion of installation of the PV modules or • 90 days after delivery of the PV modules to the Project Site. The power output warranty shall warrant the power output relative to the labeled nameplate power output (with no additional exclusions or other conditionality on coverage).
Inverter/PCS		5 years	The original equipment manufacturer's warranty shall commence no sooner than delivery of the inverters to the Project Site and continue for a minimum of five years from the warranty commencement date.
Transformer (excluding GSU transformers)	36 months	36 months	The original equipment manufacturer's warranty shall commence no sooner than the earlier of: <ul style="list-style-type: none"> • Energization thereof (in which case it shall continue through at least 18 months thereafter) or • Arrival at the Project Site (in which case it shall continue through at least 36 months thereafter).
Tracker		10 years	The original equipment manufacturer's warranty that the trackers are free from defects in material, manufacture, workmanship, and design for a period of: <ul style="list-style-type: none"> for structural components of the trackers, at least 10 years from the date of completion of the installation thereof and for motor, gear, battery, and controller components of the trackers, at least five years from the date of completion of the installation thereof.
Fixed Tilt Racking		10 years	The original equipment manufacturer's warranty that the racking is free from defects in material, manufacture, workmanship, and design for a period of: <ul style="list-style-type: none"> for structural components of the racking, at least 10 years from the date of completion of the installation.
Balance of Plant	5 years		The original equipment manufacturer's warranty shall cover combiner boxes or load break disconnects for a period of at least five years from the date of completion.

6 Training

Buyer will identify a project team to be trained by Seller during the design, construction, commissioning, and testing of the Project. Seller shall provide the required training to 8 to 12 people and through a 40-hour course. Scheduling of the training program shall be subject to mutual agreement between Seller and Buyer. The objective of the training program shall be to train Buyer's personnel to be qualified and self-sufficient in the overall operation, maintenance, and troubleshooting of each system included, so the Project is operated safely and efficiently.

Seller shall provide for Buyer's operation and maintenance staff a training program that includes training for all components and systems of the Project, including use of all related equipment and software. The training program shall include a training plan, training materials, and presentation schedule designed to

Solar BOT Scope Book Main Body

Solar BOT Scope Book

ensure a successful training program. The training program shall consist of on-the-job training during different stages of the Project and shall be supplemented by classroom instruction and computer-assisted training.

All training shall be conducted at the Project Site prior to initial operation of the Project or the generation of power therefrom. All costs of training shall be borne by Seller. Expenses incurred by Buyer's project team to attend training at the Project Site will be borne by Buyer. Seller shall be responsible for any expenses incurred by Buyer's project team for any training that occurs at any alternative locations. Training shall be held only during normal working days and hours and shall not be held on holidays or weekends or require the need for overtime of Buyer's personnel.

All presented lectures shall be conducted by personnel having extensive experience both in PV solar plant start-up, O&M, and training. All training shall include classroom and hands-on field instruction. Additional hard copies and one electronic equivalent of the training manual shall be provided to Buyer.

Training shall include:

- Plant overview
- Performance modeling basics and software operation, including control algorithms
- Introduction to Project equipment (PV modules, PCSs, trackers, met stations, transformers)
- SCADA
- Collector substation
- Control system basics
- Interconnection basics
- Operations and maintenance

Seller shall ensure the instructors have the knowledge and qualifications to participate in the training program. All instructors must be fluent in both written and spoken English.

7 Health and safety requirements

7.1 General Requirements

Seller shall prepare and implement a comprehensive Project and Project Site-specific HSE policy and associated procedures (HSE Plan) for the performance of the Work. The HSE Plan shall apply at all times during the design, preparation, construction, and operation of the Project and be prepared in accordance with and require compliance with all laws (including codes and standards) and applicable.

Seller shall submit to Buyer at least one hundred twenty (120) days prior to the Construction Commencement Date an initial HSE Plan that demonstrates Seller's commitment to the highest standards of health and occupational hygiene of the construction workforce during the development, construction, operation, maintenance, and repair of the Project. Buyer shall provide its comments to the initial proposed HSE Plan, if any, to Seller within forty-five (45) days after Buyer's receipt of the initial proposed HSE Plan from Seller and within ten (10) Business Days after Buyer's receipt of any modification to a proposed HSE Plan from Seller, and Seller shall, in each case, consider in good faith timely comments from Buyer on the proposed HSE Plan. Seller shall be responsible for implementing, complying with, and enforcing, and performing the Work in accordance with, the approved HSE Plan. Seller shall not commence Work at the Project Site until the HSE Plan has been approved by Buyer. Buyer shall not unreasonably withhold, condition, or delay its approval of an HSE Plan.

The HSE Plan shall address and include pertinent information regarding any known or reasonably anticipated safety issues arising out of the Work on the Project Site, including the equipment to be incorporated into the Project (e.g., how to properly handle generated and stored energy in emergencies)

Solar BOT Scope Book

and operation of the Project prior to substantial completion. The HSE Plan also shall set forth Seller's detailed plan for addressing environmental risks and challenges that may arise during the construction, commissioning, testing, operation, maintenance, and repair phases of the Project.

The Project shall be designed and HSE Plan (and Site Security Plan) developed to minimize the risk of injury to personnel and to the public during performance of the Work, including during the use, operation, maintenance, repair, and replacement of the Project or components thereof.

Seller shall ensure guidelines and policies for maintaining hygienic conditions and appropriate shelter or shading at eating, resting, drinking, washing facilities, and restrooms are established and adhered to by individuals at the Project Site.

The Project shall be designed to cease to energize and trip off in the event of a grid power outage. In such circumstance, the Project shall cease to energize, trip off, and physically isolate from the interconnected grid to prevent interaction with the grid (nominal auxiliary load contactors may continue to serve these loads). This shutdown and isolation mode includes both normal shutdown and system trips requiring reset.

Hazardous areas on or at the Project Site shall be identified and marked as such, and Seller shall select and install suitable equipment for use in such areas.

7.1.1 Safety Rules and Procedures

The Work shall be performed and completed in accordance with the HSE Plan and Site Security Plan. Any safety rules and procedures required for any specific activities of the Work shall be included in the HSE Plan.

7.2 Arc Flash Hazard Analysis Study and Calculation

Seller shall perform in accordance with IEEE Standard 1584 an arc flash hazard analysis study and calculation for all equipment installed pursuant to the Agreement. Arc flash hazard incident energy levels shall be limited to 8 cal/sq.cm. Arc flash hazard reduction maintenance systems may be utilized to achieve the required levels. Where 8 cal/sq.cm levels cannot be achieved, site-specific O&M procedures shall be required to address Project equipment clearance requirements.

Labeling that lists arc flash incident energy exposure levels, including instructions on disconnecting devices required for the replacement of battery modules, shall be provided.

7.3 Signage

All necessary safety signs and warnings described in ANSI Z535-2002 (entire series from Z535.1 through Z535.6) shall be included on Project Site fencing and each enclosure and any other buildings at the Project Site. All necessary signs and warnings for identification of hazardous substances as described in NFPA 704 shall be included on the fencing, each building, and any other enclosure at the Project Site. Warning signs on perimeter fencing shall be placed no further than 50-foot intervals, communicating electrical hazard and NO TRESSPASS. Each entry gate sign shall have a unique identification name and physical 911 address with contact information for emergency access.

Any object within the mowable pathway 24 inches in height or less shall have a warning sign with metal pole at least 48 inches high warning of the obstruction.

Solar BOT Scope Book

8 Submittals

8.1 Documentation to be Submitted During Project Design (Documents IFC)

Seller shall prepare and submit to Buyer the following documents during the design and engineering phase of the Project. Refer to Table 7 for requirements during design.

Table 7: Submittal requirements during project design

Item	Description	Due
8.1.1	Monthly progress reports in accordance Appendix 11 of the Scope Book	Monthly
8.1.2	Project Schedule showing, among other things, design and engineering work, procurement, and delivery of major equipment, FAT of major equipment, site surveys and studies, site preparation, construction activities, commissioning activities, and performance tests	30 days after FNTF, then with each monthly report
8.1.3	Project Execution Plan (<i>PEP</i>) document	As specified in Appendix 11
8.1.4	Drawings and documents provided with permit applications in accordance with Appendix 11 and copies of all correspondence exchanged prior to and after the closing date between or on behalf of Seller and any governmental authority with respect to the Project	As specified in Appendix 11
8.1.5	The initial, baseline Environmental Assessment (subject to the main body of the Agreement)	As specified in Appendix 11
8.1.6	Subject to Appendix 4 below, the final Energy Model, including all PVsyst project files, inputs, parameters, and reports; 30-year estimates; and P50 and P90 estimates	As specified Appendix 11
8.1.7	Project Plot Plan with landscaping notes	Per design milestones in Scope Book Section 2.2
8.1.8	General arrangement drawings	Per design milestones in Scope Book Section 2.2
8.1.9	Plans, sections, and details for each system	Per design milestones in Scope Book Section 2.2
8.1.10	Underground arrangement drawings (mechanical, electrical, and civil)	Per design milestones in Scope Book Section 2.2
8.1.11	Terminal point list	Per design milestones in Scope Book Section 2.2

Solar BOT Scope Book

Item	Description	Due
8.1.12	One-line diagrams	Per design milestones in Scope Book Section 2.2
8.1.13	Three-line diagrams	Per design milestones in Scope Book Section 2.2
8.1.14	Cable layouts	Per design milestones in Scope Book Section 2.2
8.1.15	Electrical load flow studies	Per design milestones in Scope Book Section 2.2
8.1.16	Electrical grounding calculations	Per design milestones in Scope Book Section 2.2
8.1.17	Protective relaying settings and coordination study	Per design milestones in Scope Book Section 2.2
8.1.18	Electrical short circuit analysis	Per design milestones in Scope Book Section 2.2
8.1.19	Grading and drainage drawings, including hydrology report	Per design milestones in Scope Book Section 2.2
8.1.20	Geotechnical Investigation Report	Per design milestones in Scope Book Section 2.2
8.1.21	Foundation and structural steel drawings sealed by a PE licensed in the state where the project is located	Per design milestones in Scope Book Section 2.2
8.1.22	Structural calculations for PV racking and foundations, including: All wind tunnel test reports Load derivations Corrosion calculations Detailed structural steel code checks Soil and structural embedment and deflections calculations using LPILE or equivalent Pile load test data Connection calculations Wind stow strategy plan	Per design milestones in Scope Book Section 2.2
8.1.23	Tracker or racking manufacturer drawings and calculations	Per design milestones in Scope Book Section 2.2
8.1.24	Structural calculations for PCS foundations	Per design milestones in Scope Book Section 2.2
8.1.25	Structural calculations for substation structure and foundation calculations	Per design milestones in Scope Book Section 2.2

Solar BOT Scope Book Main Body

Solar BOT Scope Book

Item	Description	Due
8.1.26	Specifications and datasheets for PV modules, PCS, tracker or racking, combiner box or load break disconnect, cables, wire management, fasteners, PV module clamps, and other equipment datasheets	Per design milestones in Scope Book Section 2.2
8.1.27	Site hydrological study	Per design milestones in Scope Book Section 2.2
8.1.28	Site Environmental Impact Assessment study	Per design milestones in Scope Book Section 2.2
8.1.29	Construction pile installation QA/QC procedure, including: <ul style="list-style-type: none"> • Pile installation tolerances • Out of tolerance remediation plan • Pile rejection criteria for damage to pile, extreme out of tolerance • Pile testing campaign for sampling population and acceptance criteria, pile load test procedure 	30 days prior to commencement of pile installation
8.1.30	System description of the main systems for the Project	Per design milestones in Scope Book Section 2.2
8.1.31	Start-up and shutdown diagrams	Per design milestones in Scope Book Section 2.2
8.1.32	Preliminary Commissioning Program with procedures for respective tests and activities	Per design milestones in Scope Book Section 2.2
8.1.33	Draft project performance test procedures	Per design milestones in Scope Book Section 2.2
8.1.34	Preliminary O&M philosophy	Per design milestones in Scope Book Section 2.2
8.1.35	Property Protection Design Basis Document as described in Section 2.3.2	Per design milestones in Scope Book Section 2.2
8.1.36	Project Site Security Plan	120 days prior to construction commencement date
8.1.37	Initial Point list for SCADA system	Per design milestones in Scope Book Section 2.2
8.1.38	Project design basis (including design criteria)	At 30% design
8.1.39	Equipment receiving, handling, storage, and installation instructions and manuals	120 days prior to construction commencement date
8.1.40	Corrosion engineering report	At 30% design
8.1.41	Field touch-up procedures of painted equipment	120 days prior to construction commencement date

Solar BOT Scope Book

Item	Description	Due
8.1.42	Site finish grade	At 30% design
8.1.43	I&C drawings (instrument list, network diagram, control panel layout, architecture, alarm list))	Per design milestones in Scope Book Section 2.2
8.1.44	MSDS documentation	120 days prior to construction commencement date
8.1.45	Visual weld inspection procedures	120 days prior to construction commencement date
8.1.46	HVAC equipment	Per design milestones in Scope Book Section 2.2
8.1.47	Electrical package including cable schedule	Per design milestones in Scope Book Section 2.2
8.1.48	Transformer recommended assembly and filling procedure	Per design milestones in Scope Book Section 2.2

8.2 Documentation to be Submitted During Project Construction

Seller shall prepare and submit to Buyer the following documents from and after the construction commencement date through substantial completion. Refer to Table 8.

Table 8: Submittal requirements during project construction

Item	Description	Due
8.2.1	Monthly progress reports in accordance with Appendix 11	Monthly
8.2.2	Weekly construction status report in accordance with Scope Book Appendix 11	No later than 5 PM Tuesday
8.2.3	Copy of all Project Work permits and Project operational permits when obtained	As obtained
8.2.4	Final Commissioning Plan	30 days prior to mechanical completion
8.2.5	Final performance test procedure	Prior to mechanical completion
8.2.6	Final O&M philosophy	Prior to mechanical completion
8.2.7	Construction Test Reports, including compaction test results and related documents for roads, substation pads, and at non-pile supported foundations and structures; in situ pile test results and related documents	Prior to mechanical completion
8.2.8	System graphics	Prior to mechanical completion
8.2.9	Certificate of achievement of mechanical completion	Prior to mechanical completion

Solar BOT Scope Book Main Body

Solar BOT Scope Book

Item	Description	Due
8.2.10	Final post-mechanical completion punchlist	Prior to mechanical completion
8.2.11	OEM FAT and shop test reports for equipment listed in Scope Book Section 5.2	Prior to initial energization
8.2.12	Environmental Assessment	No earlier than 180 days prior to closing
8.2.13	Environmental test reports, inspections, and records	Closing
8.2.14	Training manuals	Prior to mechanical completion
8.2.15	Coating specifications	Prior to mechanical completion
8.2.16	Paint color samples	Prior to mechanical completion

8.3 Documentation to be Submitted at Substantial Completion Payment Date

Seller shall prepare and submit to Buyer the following documents as shown in Table 9 prior to Substantial Completion.

Table 9: Submittal requirements prior to Substantial Completion

Item	Description	Due
8.3.1	Punchlist in accordance with the Agreement, including the agreed punchlist holdback amount	Substantial completion
8.3.2	Draft as-builts for all drawings and documents submitted during the engineering and design phase, during project construction and the final site design basis document summary.	Substantial completion
8.3.3	Power production estimates	Substantial completion
8.3.4	OEM performance field test reports	Substantial completion
8.3.5	Software licenses and Project intellectual property rights	Substantial completion
8.3.6	Instrument calibration list and certificates	Substantial completion
8.3.7	Protective relay settings list	Substantial completion
8.3.8	Equipment list	Substantial completion
8.3.9	Equipment O&M manuals	Substantial completion
8.3.10	Construction turnover documentation	Substantial completion
8.3.11	Commissioning turnover documentation	Substantial completion

Solar BOT Scope Book

Item	Description	Due
8.3.12	Input and output list	Substantial completion
8.3.13	SCADA FAT results	Substantial completion
8.3.14	Commissioning test results, bills of material, and drawings to demonstrate compliance with NERC standards	Substantial completion
8.3.15	Project Site specific operating procedures	Substantial completion
8.3.16	Arc flash study	Substantial completion
8.3.17	NERC test reports and calibration records	Substantial completion
8.3.18	Project performance test results	Substantial completion
8.3.19	All permits	Substantial completion
8.3.20	All signed and approved design change requests	Substantial completion
8.3.21	Invoices	Substantial completion
8.3.22	Spare parts and consumables lists	16 weeks prior to substantial completion

8.4 Documentation to be Submitted after Substantial Completion Payment Date

Seller shall prepare and submit to Buyer the following documents as shown in Table 10 after Substantial Completion.

Table 10: Submittal requirements after Substantial Completion

Item	Description	Due
8.4.1	Final as-builts for all drawings and documents submitted during the engineering and design phase and during project construction	Final completion
8.4.2	Red line drawings	Final completion
8.4.3	Operator and maintenance personnel training records	Final completion
8.4.4	Final equipment O&M manuals	Final completion
8.4.5	Final system descriptions of as-built systems	Final completion



Solar BOT Scope Book

Appendix 1

Collector Substation

REVISION RECORD			
Revision No.	Approval Date	Section / Page Revised	Reason / Description of Change
0	9/14/2023	All	Initial Issue
1	6/6/2024	5.3.14	Updated GSU/MPT Transformer Configurations
25-1	5/19/2025	All	Editorial corrections, clarifications, formatting throughout, added additional guidance for Generator Step-up transformers, Updated AVL/AML
26-1	3/3/2026	All	Editorial corrections

Appendix 1: Collector Substation

TABLE OF CONTENTS

1	INTRODUCTION	5
1.1	Purpose	5
1.2	Scope.....	5
1.3	General Data	5
1.4	HV Collector Substation Work	5
1.5	Deviations	6
2	DEFINITIONS, TERMINOLOGY AND ACRONYMS.....	6
3	APPLICABLE CODES AND STANDARDS	7
4	SAFETY.....	9
5	GENERAL REQUIREMENTS	9
5.1	Site Environmental Characteristics.....	9
5.2	Substation Current, Voltages and Clearances	9
5.2.1	Current Ratings	9
5.2.2	Voltage Ratings	9
5.2.3	Clearances and Spacing	10
5.3	Substation Equipment	12
5.3.1	Approved Manufacturers	12
5.3.2	HV Cables	12
5.3.3	Substation Bus/Conductors.....	12
5.3.4	Insulators	12
5.3.5	Insulator Strength	13
5.3.6	Load Combinations:	13
5.3.7	Surge Arresters	13
5.3.8	Disconnect Switches	15
5.3.9	Operating Mechanism	17
5.3.10	EHV Switches (345 kV & 500 kV) Additional Requirements.....	18
5.3.11	Line Tuners	18
5.3.12	Metering Devices.....	18
5.3.13	Coupling Capacitor Voltage Transformers & Potential Transformers.....	19
5.3.14	Circuit Breakers.....	22
5.3.15	Generator Step-Up / Main Power Transformer	24
5.4	Neutral Grounding Reactor.....	44
5.5	Station Service Transformer (Auxiliary Loads).....	44
5.6	Reactive Equipment	45
5.6.1	Circuit Switcher	45
5.6.2	Shunt Reactors.....	46
5.6.3	Shunt Capacitor Banks.....	46
5.7	Control House.....	46
5.7.1	General.....	46
5.7.2	Roof	46
5.7.3	Ceiling	46
5.7.4	Walls.....	46
5.7.5	Doors	47
5.7.6	Paint	47
5.7.7	Cable Tray	47
5.7.8	Lighting.....	47
5.7.9	Air Handling.....	48
5.7.10	Warranty	48
5.8	Substation Civil/Structural Design Criteria	48
5.8.1	Siting and Civil.....	48
5.8.2	Oil Containment.....	51

Solar BOT Scope Book: Appendix 1 Collector Substation

Appendix 1: Collector Substation

6	EQUIPMENT SUPPORT STRUCTURE LOADING	52
6.1	Load Cases.....	52
6.2	Load Combinations.....	59
6.3	Structural Analysis.....	60
6.4	Equipment Support Structure Design	60
6.5	Structure Deflection	60
7	CONTROL HOUSE STRUCTURAL DESIGN	60
7.1	Design Loads.....	61
7.2	Fall Protection.....	61
7.3	Roof	61
7.4	Cable Tray	61
8	FOUNDATIONS.....	61
8.1	Foundation Deflection and Rotation	62
8.2	Materials	62
8.3	Record Documents	63
9	FENCE & SIGNAGE.....	63
9.1	Gates	63
9.2	Signage.....	64
10	SUBSTATION PHYSICAL DESIGN CRITERIA	64
10.1	Substation Bus System	64
10.1.1	Bus Systems	64
10.1.2	Bus Configuration.....	64
10.1.3	Bus Fittings.....	64
10.2	Station Layout.....	65
10.3	Phase Orientation	65
10.4	Grounding System	65
10.5	Grounding Design Criteria	65
10.6	Grounding System Components	65
10.6.1	Soil Structure:.....	65
10.6.2	Ground Grid:.....	66
10.6.3	Grounding Rods	66
10.6.4	Grounding Connections	66
10.6.5	Above Grade Grounding Provisions.....	66
10.6.6	Crushed Rock.....	67
10.6.7	Grounding Drawings.....	67
10.7	Conduit System	67
10.7.1	Conduits	67
10.7.2	Cable Trench.....	67
10.7.3	Pullboxes	68
10.7.4	Cable Entry and Trays.....	68
10.8	Lightning System	68
10.8.1	Lighting System.....	68
10.9	Substation Security/Safety	69
10.10	Animal Deterrents	69
10.11	Substation Protection & Control Design Criteria	70
10.11.1	Protection and Control Requirements	70
10.11.2	Backup and Transfer Trip.....	70
10.11.3	Transmission Line Protection.....	70
10.11.4	Bus Protection	70
10.11.5	Transformer Protection.....	71
10.11.6	Capacitor Bank Protection	71
10.11.7	Shunt Reactor Protection	71

Appendix 1: Collector Substation

10.11.8	HV Breaker Control	71
10.11.9	HV Motor Operated Switch Control	72
10.11.10	MV Collection Feeder Protection	72
10.12	Relay Calculations and Setting Requirements	73
11	CONTROL HOUSE	73
11.1	DC System.....	74
11.2	AC System.....	74
11.3	Metering Requirements	75
11.4	SCADA	75
11.5	Communications	76
11.6	Digital Fault Recorder	76
11.7	Low Voltage Cable (Wiring).....	76
12	PHYSICAL AND ELECTRONIC SECURITY	77
13	DELIVERABLES.....	78

1 INTRODUCTION

1.1 Purpose

This Appendix to the Scope Book provides design requirements and reference material for the design of renewable energy (solar, wind, battery storage) collector substations (the **Collector Substations**) that will be built in or connected to the Project. This Appendix is intended to provide to Seller and others acting at Seller's request requirements, recommendations, and guidance in the planning, design, construction, asset management, use, and operation of the Collector Substations.

1.2 Scope

Appendix applies to all new Collector Substations.

Appendix primarily describes technical requirements, both performance-based and prescriptive for the design and installation of Collector Substations.

Refer to the Scope Book and other parts of the Agreement for information regarding Project sequencing and milestones, the Project Execution Plan, Project Schedule and schedule management, Project controls reporting, health and safety information, factory acceptance tests, training, required submittals, design reviews, equipment records, specified deliverables, Project documentation, and other relevant matters not covered by this Appendix.

Appendix 1 addresses aspects of the Work relating to Collector Substations. It is not intended to be, and shall not be construed to be, a comprehensive list of each and every element or other requirement applicable to the Work and shall in no way limit Seller's obligations under the Agreement or any Ancillary Agreement. Seller shall comply with, and cause its Contractors and Subcontractors to comply with, the terms of this Appendix 1, the Scope Book, all Laws (including codes) and applicable Permits.

1.3 General Data

This Appendix provides the Minimum Functional Specification (**MFS**) for the Collector Substations, including scope and design requirements. In addition to the Requirements set forth in the Agreement (including the Scope Book), the Collector Substations shall comply with all requirements specified in the GIA or any other Required Deliverability Arrangement.

Article, Section, Table, Figure, and Attachment references in this Appendix are to this Appendix 1 unless otherwise provided or the context otherwise requires.

1.4 HV Collector Substation Work

The Work, with respect to the Collector Substations, includes the supply, assembly, and installation of the following components:

- High Voltage (**HV**) switchgear, if applicable
- Medium Voltage (**MV**) switchgear, if applicable
- MV/HV transformer(s)
- Switchyard buses
- Revenue metering
- Circuit breakers
- Disconnect switches

Appendix 1: Collector Substation

- Overhead line
- Normal Alternating Current (**AC**) and Direct Current (**DC**) power distribution
- Backup power supply/emergency generator
- Uninterruptible Power Supply (**UPS**), if applicable
- Heating Ventilation and Air Conditioning (**HVAC**)
- Grounding (grid and conductors)
- Lightning protection system, if applicable
- Conduits and cable trays
- Cables
- Relay protection
- Relay and control panels
- DC control power (including batteries, chargers, and motoring)
- Lighting systems (including emergency lighting)
- Instrumentation and Control (**I&C**) system (including fire alarm system), if applicable
- Earthwork
- Structures
- Control enclosure
- Fencing

1.5 Deviations

Any deviations from the MFS for the Collector Substations or the terms of this Appendix 1 shall require Buyer's prior written approval and will be subject to the terms of the Agreement.

2 DEFINITIONS, TERMINOLOGY AND ACRONYMS

Terms with initial capital letters used but not defined in this document shall have the meanings ascribed to such terms in the Agreement, unless the context manifestly requires otherwise. For the avoidance of doubt, the rules of interpretation set forth in the Main Body of the Agreement shall apply to this document. The following terms, when used in this Appendix 1 have the meanings set forth below:

"Ampacity" means the current-carrying capacity, expressed in amperes, of an electric conductor under stated thermal conditions.

"Base Flood" or **"100-year flood"** means the flood level having a one percent chance of being equaled or exceeded in any given year. Note that a 100 year flood does not mean that such a flood occurs once every 100 years; instead, it means that there is a one in one-hundred (or 1%) chance of such a flood occurring in a given year. There is approximately a 63.4% chance of one or more 100-year floods occurring in any 100 year period.

"Equipment support structures" generally refers to all structures within the Collector Substation other than the control house.

"Extra High Voltage" (EHV) means Nominal System Voltage 345 kV and above.

"Finished Grade" or **"Subgrade"** means design site elevation, after site grading.

"High Voltage" (HV) means Nominal System Voltages 69 kV and higher up to 230 kV. (Note that ANSI C84.1 defines high voltage as nominal system voltage between 100 kV and 230 kV). This term is also used as an adjective to designate the high voltage winding of a power transformer.

Appendix 1: Collector Substation

“**Low Voltage**” (*LV*) means Nominal System Voltage less than 1000 volts. This term is also used as an adjective to designate the low voltage winding of a power transformer.

“**Maximum System Voltage**” means the highest system voltage that occurs under normal operating conditions, and the highest system voltage for which equipment and other components are designed for satisfactory continuous operation without derating of any kind. In defining maximum system voltage, voltage transients and temporary overvoltages caused by abnormal system conditions such as faults, load rejection, and the like are excluded. However, voltage transients and temporary overvoltages may affect equipment operating performance and are considered in equipment application. (ANSI C84.1)

“**Medium Voltage**” (*MV*) means Nominal System Voltage above 1 kV and up to 38 kV. (Note that ANSI C84.1 defines medium voltage as Nominal System Voltage above 1 kV and below 100 kV).

“**Nominal System Voltage**” means the voltage by which a portion of the system is designated, and to which certain operating characteristics of the system are related. Each Nominal System Voltage pertains to a portion of the system bounded by transformers or utilization equipment. (ANSI C84.1)

“**Substation Designer**” means for the purposes of this Appendix 1, any person, regardless of business unit or contractor or employment status, who makes decisions pertaining to the equipment to be used in a substation, or the manner in which it will be used. Generally, the term “Substation Designer” includes substation layout and relay designers.

“**System Voltage**” means the Root-mean-Square (*rms*) phase-to-phase voltage of a portion of an alternating-current electric system. Each System Voltage pertains to a portion of the system that is bounded by transformers or utilization equipment. (All voltages are rms phase to-phase or phase-to-neutral voltages.) (ANSI C84.1)

3 APPLICABLE CODES AND STANDARDS

The Collector Substation shall be designed and constructed in accordance with all applicable and up to date codes, ordinances and standard industry practices including, without limitation, ANSI, IEEE, NEMA, standards and FERC, NERC and OSHA regulations. This includes, without limitation, the standards and guidelines for substation design established by the following sources:

Applicable Standards and Organizations	
AASHTO	American Association of State Highway and Transportation Officials
ACI	American Concrete Institute
AISC	American Institute of Steel Construction
AISI	American Iron and Steel Institute
ANSI	American National Standards Institute
APLIC	Avian Power Line Interaction Committee
ASCE	American Society of Civil Engineers
ASHRAE	American Society of Heating Refrigerating and Air Conditioning Engineers
ASME	American Society of Mechanical Engineers
ASTM	American Society for Testing Materials
AWS	American Welding Society
CRSI	Concrete Reinforcing Steel Institute

Appendix 1: Collector Substation

Applicable Standards and Organizations	
IBC	International Building Code
ICE	Institution of Civil Engineers
ICEA	Insulated Cable Engineers Association
IEC	International Electrotechnical Commission
IEEE	Institute of Electrical and Electronics Engineers
IESNA	Illuminating Engineering Society of North America
ISO	International Standardization Organization
NEC	National Electrical Code
NEMA	National Electrical Manufacturers Association
NERC	North America Electric Reliability Corporation
NESC	National Electrical Safety Code
NFPA	National Fire Protection Association
OSHA	Occupational Health & Safety Administration
SSPC	Steel Structures Painting Council
UL	Underwriters Laboratories
	ACI 318: Building Code Requirements for Structural Concrete
	AISC 360: Specification for Structural Steel Buildings
	ANSI/TIA-568-C.0-2009 Generic Telecommunications Cabling for Customer Premises
	ASCE 113: Design of Substation Structures
	ASCE 48: Design of Steel Transmission Pole Structures
	American Welding Society (AWS) D1.1
	IEEE Std 605-2008: IEEE Guide for Bus Design in Air Insulated Substations
	IEEE Std 693-2018: IEEE Recommended Practice for Seismic Design of Substations
	IEEE Std 1527-2018: IEEE Recommended Practice for the Design of Buswork Located in Seismically Active Areas
	NECA/FOA 301-2009 Installing and Testing Fiber Optics
	RUS Bulletin 1724-200 Rural Utilities Service Design Manual for High Voltage Transmission Lines Electrical System Requirements
	RUS Bulletin 1724-300 Rural Utilities Service Design Guide for Rural Substations

The latest issued Applicable Standards and Codes as of the Effective Date of the Agreement shall be used. Earlier editions are not allowed unless specifically identified in this Appendix 1.

If a revision to a standard or code is issued, it is not required to be implemented unless the authorities having jurisdiction have adopted it, in which case, Seller is obligated to abide by any increased compliance requirements above what was required by the standards and codes as of the Effective Date of the Agreement. This risk is borne by Seller.

4 SAFETY

The Substation Designer shall incorporate safe work practices into the design of the Collector Substation. The Collector Substation's design and construction shall allow safe operation and maintenance under all foreseeable operating conditions. The design shall ensure that maintenance can be carried out without a significant effect on the Collector Substations operation and will allow adequate working space to maintain minimum approach distances as specified in Section 5.2.3 (Clearances and Spacing), *Table 3*.

Other aspects such as fire hazard and fire suppression and environmental aspects, such as site drainage and oil containment, shall be considered and incorporated in the design. The Substation Designer is responsible for ensuring that the Collector Substations are designed in compliance with the NESC, OSHA, and other regulations. See Section 6 (EQUIPMENT SUPPORT STRUCTURE LOADING) for further details.

5 GENERAL REQUIREMENTS

5.1 Site Environmental Characteristics

Seller shall use the criteria and values set out in ATTACHMENT 1: APPROVED MANUFACTURERS LIST FOR COLLECTOR SUBSTATION) and any other criteria and values reasonably determined by Buyer to be necessary or appropriate in the design of the Collector Substation.

5.2 Substation Current, Voltages and Clearances

5.2.1 Current Ratings

The Collector Substation bus systems, jumpers and equipment which is part of the bus shall be designed to serve the maximum equipment ratings. Equipment attached to buses, but not a part of the bus system, shall be designed to service the equipment maximum capabilities.

Any current calculation performed shall take into consideration ambient temperature, temperature rise, conductor maximum operating temperature and coefficient of emissivity. Typical and acceptable ambient temperature value for continuous ampacity shall be 40°C.

Size, variety, and types of conductors used in the Collector Substation shall be kept as minimal as practical.

5.2.2 Voltage Ratings

Equipment and bus systems shall be designed for the voltage ratings in accordance with *Table 1*. Project-specific voltage requirements shall be considered, such as high voltage or contamination, and will dictate Basic Impulse Level (**BIL**) and Basic Switching Level (**BSL**) for a specific design. This shall be coordinated and agreed upon by Seller and Buyer during Project planning phases.

Appendix 1: Collector Substation

Table 1: Equipment Voltage Ratings

Nominal Voltage (kV)	Rated Voltage (kV)	BIL (BSL) (kV)	Remarks
13.8	15.5	110	Bus, and disconnects shall be rated 34.5 kV, 200 kV BIL
24	25.8	150	Bus, and disconnects shall be rated 34.5 kV, 200 kV BIL
34.5	38	200	
69	72.5	350	
115	121	550	Circuit breakers and instrument current transformers shall be rated 145 kV and 650 kV BIL.
138	145	650	
161	169	750	
230	242	900	Instrument current transformers shall be rated 242 kV, and 1050 kV BIL
345	362	1300 (825)	
500	550	1800 (1175)	

5.2.3 Clearances and Spacing

All equipment shall be designed to maintain minimum substation clearances and spacing as outlined in *Table 2, Table 3, Table 4, Table 5, and Table 7*. The below clearances are the minimum allowable clearances for common collector substation HV and MV voltages. Values listed are for altitudes of 1000 meters (3300 feet) or less. See IEEE 1427 for altitude adjustments (if required).

Minimum electrical clearances between the conductors, and conductors to ground, shall be as tabulated below.

Table 2: Substation Minimum Clearances

Nominal Voltage (kV)	BIL (BSL) (kV)	Minimum Clearance to Ground for Rigid Parts (inches)	Minimum Clearance Between Phases (or Live Parts) for Rigid Parts, Metal to Metal (inches)
7.5	95	7	8
15	110	8	9
25	150	11	12
34.5	200	15	16
69	350	26	29
115	550	41	45
138	650	49	54
161	750	56	62
230	900	67	74
345	1300 (975)	97 (100)	105 (140)
500	1800 (1300)	135 (150)	150 (215)

Appendix 1: Collector Substation

Minimum horizontal and vertical clearances to live parts for worker safety shall be as tabulated below. These clearances are intended to prevent unintentional encroachment by a worker into the guard zone.

Table 3: Substation Minimum Safety Clearances

Nominal Voltage (kV)	BIL (BSL) (kV)	Vertical Clearance	Horizontal Clearance
7.5	95	8 ft 10 in	3 ft 4 in
15	110	9 ft	3 ft 6 in
25	150	9 ft 3 in	3 ft 9 in
34.5	200	9 ft 6 in	4 ft
69	350	10 ft 5 in	4 ft 11 in
115	550	11 ft 7 in	6 ft 1 in
138	650	12 ft 2 in	6 ft 8 in
161	750	12 ft 10 in	7 ft 4 in
230	900	13 ft 9 in	8 ft 3 in
345	1300 (828)	18 ft 11 in	13 ft 5 in
500	1800 (1167)	27 ft	21 ft 6 in

Table 4: Substation Minimum Vertical Clearances above Ground

Maximum System Voltage (kV)	Pedestrian Traffic	Roadways
7.5	14 ft 6 in	18 ft 6 in
15	14 ft 6 in	18 ft 6 in
25	14 ft 6 in	18 ft 6 in
38	14 ft 6 in	18 ft 6 in
72.5	15 ft 2 in	19 ft 2 in
121	16 ft 1 in	20 ft 1 in
145	16 ft 7 in	20 ft 7 in
169	17 ft	21 ft
245	18 ft 6 in	22 ft 6 in
362	20 ft 9 in	24 ft 9 in
550	24 ft 4 in	28 ft 4 in

Note: These clearances shall be maintained under the maximum conductor operating temperatures.

Appendix 1: Collector Substation

Table 5: Substation Minimum Horizontal Clearance to Fence

Nominal Voltage (kV)	BIL (kV)	Clearance to Fence
7.5	95	10 ft
15	110	10 ft 1 in
25	150	10 ft 4 in
34.5	200	10 ft 7 in
69	350	11 ft 7 in
115	550	13 ft
138	650	13 ft 8 in
161	750	14 ft 4 in
230	900	15 ft 5 in
345	1300	18 ft 4 in
500	1800	21 ft 6 in

5.3 Substation Equipment

5.3.1 Approved Manufacturers

A list of approved manufacturers is included in 0ATTACHMENT 1: APPROVED MANUFACTURERS LIST FOR COLLECTOR SUBSTATION). Seller shall procure items from manufacturers listed in accordance with the Agreement.

5.3.2 HV Cables

Seller shall comply with the requirements of the Generator Interconnection Agreement (**GIA**) for the design, manufacturing, installation, and testing of all HV cables.

5.3.3 Substation Bus/Conductors

Cable connections between the tube bus and equipment and between equipment shall be Aluminum Conductor Steel Reinforced (**ACSR**), All Aluminum Alloy Cable (**AAAC**) or All Aluminum Cable (**AAC**). Bus connectors shall be aluminum alloy for aluminum-to-aluminum connections and tinned bronze for aluminum-to-copper connections. Hardware connectors shall be welded onto the cable or tube. Aeolian cable shall be installed in the switchyard tubing to limit bus vibration.

5.3.4 Insulators

All insulators for the rigid bus system and disconnect switches shall be porcelain station post and shall be ANSI 70 gray in color. High strength or extra-high strength insulators may be required based on detailed analysis. Polymer station post insulators shall be used for jumper standoff support.

Insulators shall conform to ANSI C29 standards. Insulators shall be specified to satisfy mechanical and electrical requirements including creepage based on the Project contamination criteria. If contamination criteria is not available, medium (35mm/kV) shall be used.

Appendix 1: Collector Substation

5.3.5 Insulator Strength

The determination of the required cantilever strength of the insulator shall be performed in accordance with ANSI/IEEE Standard 605. The determination of the required effective bus span length due to insulator strength shall be determined for the insulator chosen and the external forces applied.

5.3.6 Load Combinations:

Case 1 – Extreme Wind:	2.5 D + 2.5 W IFW + 1.0 SC
Case 2 – Ice with Concurrent Wind:	2.5 D + 2.5 IWIFI + 2.5 WIIFI + 1.0 SC
Case 3 – Seismic:	2.5 D + 2.5 E (or EFS)IFE + 1.0 SC

Refer to ASCE 113 for definitions of the load components within the load cases above. Design values for these load cases shall be as defined in Section 7.1 (Design Loads) herein.

IEEE 605-2008 recommends a safety factor of 0.4 be applied to insulator strengths for loads other than short circuit loading and 1.0 for short circuit loading. As detailed in IEEE 605-2008, Section 12.4.2, when different load types are combined, the loads must be calibrated by the appropriate safety factor. As such, the 2.5 load factors on loads other than short circuit loading shown above are used to account for the safety factor on the insulator strength.

5.3.7 Surge Arresters

The surge arresters shall be station class, metal-oxide type. Surge arresters shall be in accordance with ANSI C62.11. The arrester housing shall be made of polymeric silicone and shall be gray in color. Arresters up to a rated duty cycle voltage of 60 kV shall be of single unit construction, and not more than 2 pieces up through 120 kV.

Arresters shall not be used as rigid bus supports. Arresters shall be installed on all incoming line terminals and at transformer terminals. Arresters shall be installed as close as possible to the equipment being protected. Duty Cycle Ratings and Maximum Continuous Operating Voltage (**MCOV**) for surge arresters shall be as shown in *Table 6* and dimensions shall be as shown in *Table 7*.

Appendix 1: Collector Substation

Table 6: Station Class Surge Arrestor Ratings

Nominal System Voltage (kV)	System Type	Rated Duty-Cycle Voltage (kV)	Rated MCOV (kV)
2.4	Effectively Grounded, wye connected system	3	2.55
	Ungrounded or Impedance Grounded, Delta connected system	3	2.55
	Distribution Networks (Note)	3	2.55
4.16	Effectively Grounded, wye connected system	6	5.1
	Ungrounded or Impedance Grounded, Delta connected system	6	5.1
	Distribution Networks (Note)	9	7.65
12.47-14.4	Effectively Grounded, wye connected system	12	10.2
	Ungrounded or Impedance Grounded, Delta connected system	18	15.3
	Distribution Networks (Note)	21	17
23	Effectively Grounded, wye connected system	21	17
	Ungrounded or Impedance Grounded, Delta connected system	36	29
	Distribution Networks (Note)	36	29
34.5	Effectively Grounded, wye connected system	30	24.4
	Ungrounded or Impedance Grounded, Delta connected system	48	39
	Distribution Networks (Note)	48	39
69	Effectively Grounded, wye connected system	60	48
115	Effectively Grounded, wye connected system	96	76
138	Effectively Grounded, wye connected system	120	98
161	Effectively Grounded, wye connected system	132	106
230	Effectively Grounded, wye connected system	192	152
345	Effectively Grounded, wye connected system	276	220
500	Effectively Grounded, wye connected system	420	335

Note: Ungrounded Distribution Network and Systems where an accidental ground can exist for long periods of time.

Appendix 1: Collector Substation

Table 7: Arrestor Housing Dimensions by Rating

Rated Duty-Cycle Voltage (kV)	Creepage Distance (inches)	Height (inches)
3	15	8
6	20	10
12	25	13
18	34	14
21	38	16
30	45	19
36	55	23
48	55	23
60	69	25
96	115	45
120	138	50
132	161	65
192	230	92
276	345	110
420	500	175

5.3.8 Disconnect Switches

Generator Step-Up (**GSU**) high-side main disconnect switches are not required when there is only a single transformer configuration. The HV line disconnect shall provide isolation to HV circuit breaker and transformer without compromising safety or operations. When a dual transformer configuration is in place, the high side transformer circuit breaker shall include disconnect switches. The GSU shall include a low side disconnect switch to allow isolation of the entire transformer zone without the need of opening feeder circuit breaker hooksticks.

The disconnect switches shall be three-pole, group operated, single-throw complete with station post insulators, switch blades, contacts, operating mechanisms and include all necessary hardware for the assembly and mounting to steel structures. All disconnect switches shall conform to IEEE Standard C37.30.1 for HV switches. Ratings for disconnect switches shall be as shown in *Table 8* and *Table 9*.

Standard practice is to orient the vertical and side break switches so that the blade shall be dead when the switch is in the open position, i.e., the hinge shall be towards the closest circuit breaker.

All disconnect switches shall be provided with arcing horns which will interrupt charging or magnetizing currents to prevent any arcing at the main switch contacts. Grounding switches will be required for HV line disconnect switches. The line disconnect switch and associated ground switch shall be mechanically interlocked to avoid mis-operation, i.e. closing the line disconnect switch when the ground switch is closed and vice versa.

Appendix 1: Collector Substation

Table 8: HV Disconnect Switch Ratings

Nominal Operating Voltage (phase-to-phase)	230 kV	161 kV	138 kV	115 kV	69kV	34.5 kV
Maximum Voltage (phase-to-phase)	See Table 1					
Basic Impulse Level	See Table 1					
Maximum Continuous Current (amperes)	To be determined after study results					
Short Time Withstand (symmetrical) Current	To be determined after study results					
Preferred Configuration Type	Vertical Break/Double End Break/Center Break				Vertical Break/Center Break/ Hookstick	

Table 9: EHV Disconnect Switch Ratings

Nominal Operating Voltage (phase-to-phase)	345 kV	500 kV
Rated Voltage	362 kV	550 kV
Lightning Impulse Withstand Voltage	1300 kV	1800 kV
Switching Impulse Withstand Voltage	885 kV to ground 1120 kV across open gap	1150 kV to ground 1450 kV across open gap
Rated Continuous Current:	2000 A, or 3000 A (Note)	2000 A, or 3000 A (Note)
Rated Short Time Withstand	63 kA rms, 164 kA peak	63 kA rms, 164 kA peak
Short-time Current Withstand Duration	3 seconds	3 seconds

Note: To be determined after study results

Line switches shall be monitored by the Remote Terminal unit (**RTU**) or Supervisory Control and Data Acquisition (**SCADA**) system.

All disconnect switches whether motorized or not will have auxiliary contacts for system monitoring. Auxiliary contacts on motorized switches will not be actuated by the motor cam but will be triggered based on the physical switch position.

Electrical interlocks shall be installed to prevent opening of motor operated disconnects and/or grounding switches when the station main breaker is in the closed position.

The complete switch assembly shall have a rated ice breaking ability to open and close with a ¾ inch thick coating of ice.

Gradient control rings shall be provided for switches at 230 kV and higher voltages on both the hinge end and the jaw end to fully shield the live mechanism parts including the terminal pads.

Appendix 1: Collector Substation

Flexible braids are not acceptable as by-pass shunts. Flexible laminated current carrying components are acceptable only when welded connections are made on each end. Bolted connections are not acceptable on laminated components. All moving contact surfaces for current transfer shall be silver or silver alloy. Aluminum or plated aluminum is not acceptable.

The switches shall be free of visible corona at 110% rated voltage. The Radio Influence Voltage (*RIV*) shall not exceed 300 microvolts.

All fastenings, nuts, bolts and washers utilized in the non-live parts area shall be of hot-dipped galvanized steel. Plated fastenings are not acceptable.

All bearings shall be heavy duty with stainless steel balls and races. Aluminum or its alloys are not acceptable as a material for bearing raceways or bushing surfaces.

Bearings shall be maintenance free and not located in the current carrying path. Switch bearings shall be lubricated and sealed and shall not require further field lubrication. Dry type, non-lubricated type bearings will be preferred. Lubricant shall be non-deteriorating with a projected shelf life in excess of ten years. All bearing assemblies shall be weatherproofed with corrosion-free seals.

All switches supplied with a manual operating mechanism shall be readily convertible to motor operation.

Maintenance ground studs shall be supplied on both hinge and jaw sides of the switch for attachment of portable ground cables. Design of the ground stud attachment shall be such that presence or absence of the ground studs will not change the switch height from its base to the top of the switch terminal pads. Ground studs shall be capable of being added to a switch in the field without undue switch dismantling. The ground studs shall be corona-free and shall be fully shielded where necessary. The ground stud material shall be the same as that of the switch contacts. The ground stud length shall be at least 6 inches for attaching the portable ground cable clamps and have sufficient strength to support a 50 feet length of a 4/0 copper portable ground cable.

5.3.9 Operating Mechanism

Hookstick operated switches may be used for equipment or circuit isolation, and regulator bypass applications up to 34.5 kV. Hookstick operated disconnect shall be located to provide switch operator space to allow 45-degree switch stick angle, for opening or closing, without operator or switch stick bumping into adjacent equipment, structures or foundations. Escape paths shall be considered in layout to deal with arcing or equipment failure that might occur during switching any switch or local breaker operation.

Switches shall be supplied with a manual three-phase group operated mechanism. The operating mechanism shall be designed such that the complete three-phase switch assembly can be operated to fully open and closed positions by one person with a force of not more than 35 pounds applied to the actuating handle.

The vertical operating pipe operation for switches up to and including 145 kV shall be torsion operated by a swing handle. The swing handle shall be galvanized steel pipe not less than 3 feet in length. The switch design, where operation with a swing handle would require a force greater than 35 pounds, shall utilize a worm gear operator.

The vertical operating pipe operation for 170 kV and 230 kV switches shall be torsional operated by a worm gear in lieu of swing handle.

For 363 kV and 550 kV switches, the switch shall be supplied preferably with a three-phase torsional gear drive mechanism with a gearbox for each pole. The operating mechanism shall be designed such that the complete three-phase switch assembly, can be operated to fully open and closed positions with a force of not more than 35 pounds, applied to a manual actuating handle. The worm gear operator, when supplied, shall be in a sealed housing, corrosion and maintenance free. The gear operator shall be self-locking and

Appendix 1: Collector Substation

prevent back driving of the crank handle during operation. The operating crank handle shall be no more than 15 inches in length.

Status indication of operator position is not required for manually operated switches but is required for motor operated switches.

5.3.10 EHV Switches (345 kV & 500 kV) Additional Requirements

The mounting location for the switch operating handle and/or the motor operator shall be the center pole support column.

The switch shall use porcelain station post insulators ANSI TR number 368, rated 1300 kV BIL for 362 kV switches and ANSI TR number 391, rated 1800 kV BIL for 550 kV switches.

5.3.11 Line Tuners

Communication using carrier equipment (line traps and tuners) shall not be used.

5.3.12 Metering Devices

5.3.12.1 General

Metering systems for the Project shall be designed and installed to monitor and record all energy traveling to and from the Project and to permit the evaluation of the functionality and efficiency of the overall Project.

Shorting-type terminal blocks shall be provided for all current transformer circuits to allow meters to be removed without disrupting current transformer circuits.

A set of metering current transformers on the GSU secondary shall be provided. Potential transformers (**PTs**) shall be provided on the medium voltage buses for input to the meters. Shorting-type terminal blocks shall be provided to allow meters to be removed without disturbing current transformer circuits.

All permanently installed electrical metering instrumentation, or a combination of temporary test and permanently installed instrumentation, that will be used for the Project Performance Tests shall comply with maximum allowable measurement uncertainties per ASME PTC 22.

Except where more restrictive requirements apply, relaying class accuracy voltage and current transformers are acceptable for panel indication meter applications.

ABB FT-1 type test switches shall be provided for the voltage and current inputs to each meter.

5.3.12.2 Revenue Metering

The revenue metering system shall be included in the Work except for installation of the revenue meters, which shall be performed by Buyer. Seller shall purchase the revenue meter(s) from [Entity] Transmission during the design phase of the Project. Notwithstanding anything herein to the contrary, all revenue meters, installation and purchases thereof, and revenue metering shall be in accordance with the GIA or other applicable Required Deliverability Arrangement (to the extent applicable).

All meters shall conform to ANSI Standards C12.20, C12.1, and C12.10.

Seller shall provide and install high accuracy 0.15 B 1.8 extended range Current Transformers (**CTs**) and 0.15 Z accuracy PTs for GSU high-side revenue metering.

Seller shall provide the revenue meter cabinet(s) to Buyer's specifications. Seller shall design and install all wiring needed for revenue metering. Buyer shall install the revenue meters and make the final connections to the meters. Seller's schedule for the Work shall allow a reasonable period of time for Buyer

Appendix 1: Collector Substation

to undertake, complete, and test such installation and final connections, and Seller shall use commercially reasonable efforts to cooperate with Buyer in connection with such installation and final connections.

5.3.12.3 Metering Locations

Other than where included with standard equipment packages (e.g., inverters), indication metering shall be provided in the following locations:

- High side of each GSU (voltage, current, kW, and kVAR)
- Each medium voltage main breaker (voltage, current, kW, and kVAR)

5.3.13 Coupling Capacitor Voltage Transformers & Potential Transformers

Voltage transformers and/or Coupling Capacitor Voltage Transformers (**CCVTs**) are required to provide a low voltage supply to protective relays and metering equipment.

Voltage transformers, Capacitor Voltage Transformers (**CVTs**) and CCVTs are directly connected to the high voltage bus. Fuses shall not be used on the high side of the voltage transformer.

Auxiliary transformers are not permitted.

Refer to *Table 10* and *Table 11* for required CCVT and PT ratings, respectively.

Table 10: CCVT Ratings

Nominal System Voltage (kV)	Maximum Line to Ground Voltage (kV)	BIL (kV)	Performance Reference Voltage (kV)	Nameplate Ratio	Nameplate Secondary Voltage (V)	Accuracy
69	42	350	40.25	350 / 600:1	115 / 67.1	0.6 WXYZ
115	70	550	69	600 / 1000:1	115 / 69	0.6 WXYZ
138	84	650	80.5	700 / 1200:1	115 / 67.1	0.6 WXYZ
161	98	750	92	800 / 1400:1	115 / 65.7	0.6 WXYZ
230	140	1050	138	1200 / 2000:1	115 / 69	0.3 WXYZ, ZZ
345	209	1550	209	1800 / 3000:1	115 / 69	0.3 WXYZ, ZZ
500	318	1800	287.5	2500 / 4500:1	115 / 63.8	0.3 WXYZ, ZZ

Appendix 1: Collector Substation

Table 11: PT Ratings

System Voltage (kV)	BIL (kV)	Primary Voltage (kV)	Marked Ratio	Secondary Voltage (each winding) (V)	Accuracy / Burden	Minimum Thermal Burden (VA)
15	110	7.2 / 12.47 Grd Y	60:1	120	0.3 Z	1000
15	110	8.4 / 14.4 Grd Y	70:1	120	0.3 Z	1000
25	150	14.4 / 24.9 Grd Y	120 / 200:1:1	120 / 72	0.3 Z	1000
34.5	200	20.125 / 34.5 Grd Y	175 / 300:1:1	115 / 67.08	0.3 Z	1000
69	350	40.25 / 69 Grd Y	350 / 600:1:1	115 / 67.08	0.3 ZZ	2000
115	550	69 / 115 Grd Y	600 / 1000:1:1	115 / 69	0.3 ZZ	2000
138	650	80.5 / 138 Grd Y	700 / 1200:1:1	115 / 67.08	0.3 ZZ	2000
161	750	92 / 161 Grd Y	800 / 1400:1:1	115 / 65.71	0.3 ZZ	2000
230	1050	138 / 230 Grd Y	1200 / 2000:1:1	115 / 69	0.3 ZZ	2000

5.3.13.1 Current Transformers

All current transformers shall be in accordance with ANSI-C57.13 and shall meet the following requirements.

Relaying: Bushing type, fully distributed winding, five lead multi-ratio, C800 or as specified. (X and Y positions on a breaker bushing 69 kV and higher; X position on a breaker bushing 34.5 kV only.)

Metering: Bushing type, fully distributed winding, single- or dual-ratio, 0.15% B-0.9 and 0.30% B-1.8 or as specified. To be installed at the Z position on a breaker bushing for 69kV and higher or on the Y position on a breaker bushing at 34.5kV. See Section 5.3.12.2 (Revenue Metering).

Free standing post type current transformers shall be designed to operate at an average ambient temperature of 30°C and with a winding temperature rise not to exceed 55°C. In Buyer's service area, the ambient temperature under full sun can reach as high as 45°C to 50°C.

The minimum thermal rating shall be 2.0.

If continuous load is going to be "X" amps, then the CT shall also be rated "X" amps. Before applying a lower rated CT to benefit from the rating factor the application shall be evaluated thoroughly, and it is generally acceptable only if the peak load is seldom expected and for a very short duration.

Generally, the current transformer rated primary current shall be 10% to 40% above maximum load current when peak load information is unknown. Consideration shall also be given to short circuit levels. The maximum CT ratio shall be selected so that the maximum fault current is less than 20 times the maximum current tap, and so that the maximum secondary CT current is less than 100 amps under maximum fault conditions. An additional rating margin of not less than 25% shall be provided to accommodate future increased fault levels.

Refer to *Table 12* and *Table 13* for required minimum CT ratios and CT accuracy, respectively.

Appendix 1: Collector Substation

Table 12: CT Ratios

Fault Current (kA)	Minimum CT Ratio
48 – 64	4000/5
32 – 48	3000/5
20 – 32	2000/5
0 – 20	1200/5

Table 13: CT Accuracy

	At RF *100% Rated Current	At 10% Rated Current	At 5% Rated Current	At ≤ 1% Rated Current
0.3	0.3%	0.6%		
0.3 S	0.3%		0.3%	
0.15	0.15%	0.3%		
0.15 S	0.15%		0.15%	0.15%

The CT shall have the following primary current and minimum short-time thermal current ratings, rms for one second. For bushing and slip-over CTs these ratings apply to the secondary winding only.

Table 14: CT Short-Time Thermal Current

Maximum System Voltage (kV)	Primary Current (A)	Short – time Thermal Current (kA)
15.5	1200	25
	2000	31.5
	3000	40
25.5	1200	25
	2000	31.5
36.5	1200	25
	2000	31.5
	3000	40
72.5	2000	40
	3000	63
123	2000	40
	3000	63
145	2000	40
	3000	63
170	2000, 3000	40
245	2000	40
	3000	63, 80
362	2000	40
550	3000	40

Appendix 1: Collector Substation

5.3.13.2 CT/PT Combo Units

CT/PT combo units are not allowed. Exceptions must be approved by Buyer in writing.

5.3.14 Circuit Breakers

Circuit breakers shall be three phase dead tank design with current transformers on each bushing. A sufficient number of CTs shall be supplied to support the system protection and metering requirements. Circuit breakers shall use SF6 or vacuum interrupters.

DC power for the circuit breaker operation and protection will be 125 VDC.

Bushings shall comply with the requirements of IEEE Std C37.017. Voltage class and the current rating of the bushings and insulators shall not be less than that of the circuit breaker.

Continuous current rating factor (**RF**) shall be 2.0 in accordance with IEEE Std. C57.13.

HV and MV breakers shall not have internal 43 Local/Remote switches. If the breakers do come with a 43 device, the device shall be jumpered out. The only 43 Local/Remote switch shall be in the relay panel in the control house, near the 52 CS. The relay panel 43 switch associated with each breaker shall be a three-position switch, with “Local”, “Remote”, and “Maintenance” positions only (i.e., no “Off” position).

HV and MV breakers shall permit local tripping (i.e., tripping via the control switch in the breaker cabinet OR the 52 CS in the relay panel) regardless of the position of the relay panel 43 switch associated with that breaker. HV and MV breakers shall permit local closing ONLY when the relay panel 43 switch associated with that breaker is in the “Local” position. HV and MV breakers shall permit remote closing ONLY when the relay panel 43 switch associated with that breaker is in the “Remote” position. The “Maintenance” position will be used when working on the circuit and shall initiate a different set of relay settings.

All circuit breakers shall have dual trip coils. Trip coil 1 and the close coil shall be on the same 125 VDC circuit. Trip coil 2 shall be on a separate 125 VDC circuit. Trip circuits shall be in separate cables.

A platform shall be installed for maintenance access if operators will not or would not reasonably be expected to be able to reach all breaker equipment while standing at grade (cabinet access 60” or higher). Seller shall perform a detailed review of breaker manufacturer drawings to ensure that operability concerns, such as proper cabinet heights or the need for a platform, are addressed.

5.3.14.1 High Voltage Circuit Breaker:

HV power circuit breakers shall be SF6 gas insulated, dead-tank, “puffer” type design with a spring-spring type operating mechanism. Auxiliary contacts for breaker internal control functions shall be provided plus additional form “a” and form “b” field convertible contacts per *Table 15*. Circuit breakers shall conform to IEEE C37. Circuit breaker ratings shall be as shown in *Table 15*.

Appendix 1: Collector Substation

Table 15: HV Circuit Breaker Ratings

Rated Maximum Voltage		72.5 kV	123 kV	145 kV	170 kV	242 kV
Rated Continuous Current (as specified)		1200 A 2000 A	2000 A 3000 A	2000 A 3000 A	2000 A 3000 A	2000 A 3000 A
Rated Short Circuit Current (to be determined after study results)		40 kA	40 kA 63 kA	40 kA 63 kA	40 kA	40 kA 63 kA
Lightning Impulse Withstand Voltage		350 kV	650 kV	650 kV	750 kV	900 kV
Rated Interrupting Time		5 cycles	3 cycles	3 cycles	3 cycles	3 cycles
Rated shunt Capacitor Switching current		630 A	315 A	315 A	400 A	400 A
Additional Auxiliary Contacts	Form "a"	12				
	Form "b"	12				

The alarm for SF6 gas breakers shall be annunciated at the operations control center. SF6 meter/monitor shall be suitable for the loss of SF6 emissions. All of the available alarms for HV breakers shall be inputs into the substation RTU and made available to the Electric Reliability Coordinating Council (**ERCC**) via the communications network.

All HV circuit breakers shall have low SF6 pressure alarms and emergency operations for:

Stage 1: Low gas pressure

Stage 2: Auto-trip of the trip coil 1 and trip coil 2 circuits and block close of the close coil circuit.

Stage 3: Block-trip of the trip coil 1 and trip coil 2 circuits and block close of the close coil circuit.

5.3.14.2 EHV Circuit Breakers (345 kV & 500 kV)

Additional specific requirements pertaining to 345 kV & 500 kV circuit breakers will be provided under separate cover where applicable.

5.3.14.3 Medium Voltage: Collector Feeders and Reactive Breakers:

MV circuit breakers shall be rated for outdoor, three-poles, gang operated, dead tank, frame mounted vacuum type with motor charged operating mechanism in conform to IEEE C37. MV circuit breaker ratings shall be as shown in *Table 16*.

Appendix 1: Collector Substation

Table 16: MV Circuit Breaker Ratings

Nominal Operating Voltage (phase-to-phase)	34.5 kV
Maximum Voltage (phase-to-phase)	See <i>Table 2</i>
Basic Impulse Level	See <i>Table 2</i>
Maximum Continuous Current (amperes)	To be determined after study results
Short Circuit Interrupting Current (kA)	40kA with full back-to-back switching capability; tested and proven*
Interrupting Time (cycles)	3
Independent Pole (Phase) Operators	N/A
Duty Cycle	O-0.3 sec – CO -3 min - CO
Spring Motor Voltage	125VDC
AC Heaters and Receptacle Voltage	120/240VAC
Additional Auxiliary Contacts	Forms “a” and “b”

*40kA analysis - use conservative design/results. The results of final short circuit model shall dictate the final rating.

5.3.15 Generator Step-Up / Main Power Transformer

This Section describes requirements for the Main Power Transformer (**MPT**) within the Collector Substation. This item is also referred to as the Generator Step-up (**GSU**) transformer. The GSU connects the medium voltage collector system to the high voltage interconnecting transmission system.

The GSU shall be built to ANSI/IEEE C57. The GSU shall be an outdoor, oil-filled power transformer and designed in accordance with the Project Site climactic conditions. Unless otherwise specified, winding connections for the transformer shall be a wye-g/wye-g/delta (internally buried) configuration with a neutral grounding bushing on the high and low sides. The low-side winding shall be appropriately insulated when specified for use with impedance grounding applications.

The GSU ratings shall be based on the Project’s expected total generation at all operating power factors, including all applicable derating factors and confirmed through software simulations. A minimum 10% design margin shall be included.

The GSU shall be purchased complete with bushings, current transformers, tap changers, surge arresters, cooling equipment (such as radiators & fans), and control/monitoring system equipment.

Ancillary equipment such as bushings, tap changer, winding leads, etc., shall not restrict the transformer loading to levels below those permitted by the winding conductor. The transformer shall be capable of carrying loads above its nameplate rating in accordance with IEEE C57.91. All internal parts of the transformer shall be designed to withstand the accelerations encountered on the US and other railroads enroute to the point of delivery. The design criteria for rail shipment shall be 5g longitudinal, 3g transverse, and 3g vertical.

Table 17 below provides some recommended transformer specifications to consider. Project specific engineering requirements may differ from the recommended specification listed in this table.

Appendix 1: Collector Substation

Table 17: Transformer Recommended Specifications

Project MW		260	240	195	150	100	20
Transformer MVA	ONAN	180	168	135	105	69	18
	ONAF1	240	224	180	140	92	24
	ONAF2	300	280	225	175	115	
%Z (H-X, Positive Sequence)		9.0%	9.0%	8.5%	8.5%	8.0%	8.0%
X ₀ Neutral Reactor		Yes	Yes	Yes	Yes	No	No
Assumptions: 1. Power factor range required at point of interconnect is +/- 0.95 2. Inverters are capable of +/- 0.8 power factor 3. Substation is not close to synchronous generation switchyard 4. Transformers over 300 MVA not recommended due to 34.5 kV fault current. ONAF2 Rating should be 115% of the Project MW rating. 5. Based on transformer winding configuration: HV (wye-gnd); XV (wye-gnd); XV (delta-buried)							

5.3.15.1 Loss Evaluation

The test system accuracy for measuring losses shall be as specified in IEEE C57.12.00. The calibration and the accuracy of the test equipment shall be traceable to the National Institute of Standards and Technology.

The manufacturer shall guarantee the following losses for each transformer:

- No-load loss in kilowatts at rated voltage and rated frequency
- Total losses (sum of no-load loss and load loss) in kilowatts at ONAN rated output, rated voltage and rated frequency
- Auxiliary losses (all cooling in operation)

Load losses shall be evaluated on the ONAN 65°C rating for each transformer.

Transformer losses determined under tests shall be corrected to 85°C. No-load loss shall not be corrected to 20°C.

5.3.15.2 Non-Conformance

Entergy reserves the right to reject a transformer that exceeds the specified temperature rise limits. If a transformer exceeds the 65 °C temperature rise limit during tests at rated loads, and / or exceeds the 80 °C hottest spot winding temperature rise (measured or calculated) resulting in a de-rating of capacity, then a price penalty of 2.0% of the transformer purchase price for each °C by which the temperature rise is exceeded shall apply. No credit shall apply if the actual test temperatures are lower than rated.

5.3.15.3 Service Conditions

The power transformer fully assembled with accessories and auxiliary equipment shall be suitable for installation and operation in an ambient temperature range of – 20 °C to + 40 °C, withstand hurricane winds up to 150 mph, or a one-inch-thick coating of ice with wind up to 40 mph. The transformer shall be designed according to the requirements of IEEE Std 693 Annex D. The transformer assembly shall be designed to withstand seismic loading as specified in IEEE 693.

Solar BOT Scope Book: Appendix 1 Collector Substation

Appendix 1: Collector Substation

All control components shall be capable of operating in a temperature range of minus 20°C to plus 70°C in the control cabinet(s). The control cabinet design shall ensure that all control components will operate satisfactory when the transformer is loaded at 120% of its nameplate rating in a 40°C ambient temperature, 90% relative humidity, in full sun with no wind. The control cabinet design shall ensure that damage from condensation inside the cabinet is prevented.

5.3.15.4 Winding Insulation

The BIL of the transformer windings and bushings shall be as listed below for the specified nominal system voltage.

Table 18: Transformer Winding BIL

Nominal System Voltage (kV)	Winding Lightning Impulse Level (kV)
500	1550
345	1175
230	825
161	650
138	550
115	450
69	350
34.5	200
24	150
13.8	150

The inter-winding insulation system between windings, phases and to ground shall be designed for maximum voltage stress and with a safety margin of 20% for the oil space stresses. Weidmann de-gassed oil gap curves shall be used to determine the field stresses. Design insulation level (**DIL**) factors shall be as follows:

- Lightning impulse: 2.5
- Switching impulse: 1.8
- Induced test (enhanced): 0.8

The use of Metal Oxide Varistor (**MOV**) or other internal devices to control voltage transients is not allowed without prior approval from the buyer. If used, the location shall be shown on the nameplate winding schematic and must be accessible from the top of the transformer without draining of the oil.

5.3.15.5 Impedance

The transformer percent impedance at the self-cooled (ONAN) rating, with and without a Load Tap Changer (**LTC**) shall be as specified in *Table 19* below (for 345 kV and 500 kV, requirements will be provided under separate cover);

Appendix 1: Collector Substation

Table 19: Impedance

HV Winding Voltage (kV)	Impedance %	
	Without LTC	With LTC
230	10.0	10.5
161	9.5	10.0
138	9.0	9.5
115	8.5	9.0
69	8.0	8.5
34.5	7.25	7.5
24	6.75	7.0
13.8	6.75	7.0

5.3.15.6 Winding Temperature

The maximum average winding temperature rise shall be 65°C. The maximum hottest-spot temperature rise of the winding shall not exceed 80°C. The maximum hottest-spot temperature rise of any metal components in the transformer core and tank whether in contact or not in contact with the paper insulation, shall not exceed 80°C at an ambient temperature of 40°C.

The calculated maximum temperature rise of any lead or connection shall not exceed the calculated maximum winding hottest spot temperature rise.

The temperature of any serviceable metal parts, gauges, switch handles, etc., located in the control cabinet that may be touched by an operator under normal operation shall not be affected by the transformer and shall not exceed the ambient temperature by more than 10°C at maximum rated load.

Winding hottest-spot calculations shall be made for each winding using the maximum localized losses including the eddy current losses, the insulation thickness at the points of maximum localized losses, and the oil rise in the winding. If Seller is unable to measure the oil rise in the windings, an allowance will be made for the added rise at the design review. These results shall be used in calibrating the hot-spot temperature indicator.

5.3.15.7 Audible Sound Level

The audible sound level shall not exceed levels specified in the NEMA TR-1.

5.3.15.8 Short Circuit Capability

The transformer shall be designed and constructed to withstand, without damage, the effects of both three-phase and line-to-ground through-faults at either of the transformer HV, LV, or Tertiary Voltage (**TV**) terminals. The windings shall not exceed the IEEE thermal limits for the duration of 2 seconds. The pre-fault operating voltage on the non-faulted terminals shall be 1.05 per unit rated voltage.

All windings shall be designed for an infinite bus condition i.e. system impedance shall not be used in the calculation of the fault currents. The inner windings shall be designed to withstand maximum short circuit forces in an unsupported buckling mode (free buckling), assuming no radial mechanical support from the core. The windings shall also be designed for forced or supported buckling.

For shell form transformers, the maximum allowable tolerance for the support members between the core and the tank walls shall not exceed 1 mm.

Appendix 1: Collector Substation

5.3.15.9 Laminated Iron Core

The iron core shall have grain-oriented steel, and all core joints shall be the mitered step-lap design. No core through-bolts are allowed in the design.

The transformer core shall not be saturated when operating at 115% of rated voltage

The cooling ducts in the core shall be either ceramic, high temperature fiberglass, or buyer approved equivalent.

High temperature fiberglass or Nomex insulation or other Buyer approved high temperature material shall be used for the insulation between the tie plates and the core.

The iron core shall be designed such that at full load and with 105% rated secondary voltage, the maximum core temperature (hotspot) shall not exceed 120°C (80°C rise at 40°C ambient), and the maximum tie plate or core surface temperature rise shall also not exceed 120°C (80°C rise at an ambient of 40°C).

The top and bottom T beams in Shell Form transformers shall be insulated from the core and tank. Separate grounds shall be brought from the various sections of the core to terminals in a weatherproof enclosure. Separate grounds shall be brought to separate terminals from the T- beams.

5.3.15.10 Windings:

All windings shall be circular. All winding conductor material shall be copper, and all other current-carrying parts shall be copper or silver, or alloy(s) of copper and/or silver.

The current density in the winding conductor under maximum rated power at 65°C temperature rise shall not exceed 4 A / mm² (2580 amps per square inch).

The winding conductor insulation shall be thermally upgraded paper meeting the life criteria as defined and verified in IEEE C57.100. The minimum nitrogen content of the upgraded paper when tested by ASTM standards shall not be less than 2%.

When more than one high-side or low-side voltage rating is specified, series multiple connections shall be made using an external switch or (preferably) brought to a terminal board readily accessible through a hand hole(s) in the cover. Changing of connections shall be designed to avoid disturbing the insulated leads. Terminal boards shall be accessible without lowering the oil and shall employ captive hardware.

5.3.15.11 Tank Construction, Physical Features & Finish

All welding shall be in accordance with ANSI/AWS D1.1 / D1.1M, American Welding Society Steel Structural Welding Code.

The transformer tank shall be of welded sheet steel construction, free from distortion and provided with a steel base to permit rolling and skidding of the transformer in any direction. The transformer "footprint" shall have a maximum pressure of 5000 pounds per square foot.

The transformer tank cover shall be welded to the tank using flanges to facilitate removal. All tank joints and penetrations (except cover) shall be welded both on the inside and the outside.

The main tank, radiators, conservator, and LTC compartment(s) as applicable shall be designed to withstand full vacuum and at least 10 psig positive pressure without leakage or distortion.

There shall be two (2) or more round manholes in the main tank cover. Manhole covers shall be round with 2 lift-handles. The minimum inside diameter of manholes shall be 20 inches.

The tank cover shall be peaked or sloped to prevent rainwater accumulation. All oil and gas seal designs shall have grooves for gasket retention and shall have groove-depth controlled compression for maximum seal life.

Appendix 1: Collector Substation

Fall protection system consisting of FALLSOFT GM 135 fall arrest anchor plates for rescue purposes be supplied. One anchor plate shall be welded at each manhole location and one anchor plate shall be welded at the least congested corner of the transformer tank. All gaskets shall be one-piece, oil-resistant nitrile elastomer or Fluoro elastomer, such as Viton, compatible with the transformer operating temperature. All gasket materials shall be verified in accordance with ASTM D3455 to be compatible for the intended use with transformer oil. The gasket material shall also be fully compatible with the fluids used in the bushings. Gaskets shall not be exposed to the weather. The gasket material shall also be fully compatible with the fluids used in the bushings.

The transformer tank and all oil-filled accessories shall be labeled with a “NON PCB” permanent tag.

The location of the “shipping” and “dressed” center of gravity shall be marked with raised letters and symbols on the transformer tank.

A minimum of four stainless steel ground pads shall be provided welded to the tank wall on each corner near the base and shall be as specified in IEEE Std C57 12.10. Support brackets shall be welded to the tank wall to support the neutral and surge arrester ground leads. Support brackets and the copper bus bar down leads with necessary connectors from the neutral terminal and the surge arresters ground terminals to the grounding pads near the bottom of the transformer case shall be provided by the transformer manufacturer. Ground conductors for the neutral and arrester grounds shall be ¼ inch x 2 inch (minimum) rigid copper bar. The HV & LV side ground busbars shall run along the top and down the tank sidewalls on both ends of the transformer. The busbars shall be attached to supports welded to the tank sidewalls and shall be grounded to the NEMA 2-hole ground pads near the tank base.

Insulating oil shall be inhibited, type II, 0.3 percent DBPC, or DBP. Insulating oil shall be non-corrosive when tested in accordance with a modified ASTM D-1275 Part B requiring a minimum duration of 48 hours at a minimum temperature of 150 °C. Insulating oil shall not contain any detectable PCB's. Purchaser shall be contacted for oil shipping instructions.

5.3.15.12 Oil Preservation System

The oil preservation system shall be a sealed-tank system with a constant pressure inert gas-pressure or conservator/diaphragm system.

5.3.15.13 Conservator Tank System

The tank (or conservator) shall have sufficient capacity to ensure that oil will not be below low-oil trip level at an ambient temperature of –20 °C with transformer de-energized and will not overflow at an ambient temperature of +40 °C when the transformer is loaded at 125% of its nameplate rating in accordance with IEEE Std C57.91.

The conservator shall include a diaphragm that completely separates the insulating oil from the atmosphere. The conservator shall be supplied with a maintenance free dehydrating breather.

A gas collector system shall be mounted on the transformer main tank cover and shall tap the tank cover at adequate intervals (bushing pockets if used) to allow all gases that are generated in the tank to freely enter the gas collector system. The gas collector system shall be equipped with a valve, located a maximum of five (5) feet above the transformer base, for gas sample collection and the release of excess gasses from the system. The valve opening shall be capable of accepting ¼ inch plastic tubing for collecting gas samples. The collecting system shall be designed to shed water off the top of the transformer to prevent standing water.

The conservator and the piping shall be provided with valves and fittings for complete oil filling of the main tank, turrets, radiators, and the conservator under vacuum.

Appendix 1: Collector Substation

The diaphragm in the conservator shall be made of a flexible oil- and fungus resistant nitrile elastomer. The diaphragm manufacturer shall determine the leakage rate through the rubber preferably using helium gas. The gas permeation rate through the rubber shall be such that the oil will not become saturated for a minimum of twenty years. The bags shall be Pronal, Musthane or buyer approved. Drawings of the diaphragm shall be included in the instruction manual.

5.3.15.14 Inert-Gas Pressure System

The tanks of transformer with inert-gas pressure system shall have sufficient capacity to ensure that the oil will not be below the low-oil trip level at an ambient temperature of -20 °C with the transformer de-energized. The internal gas pressure in the transformer tank shall not exceed 8 psig at an ambient temperature of + 40 °C with the transformer loaded at 125% of its nameplate rating.

Inlet and outlet fittings for Nitrogen connections in the transformer shall be located on diametrically opposite sides of the transformer tank wall. Shut off valves to isolate the Nitrogen system shall be mounted at a height less than six feet from the base of the transformer.

The nitrogen gas bottle shall be located on a shelf 3 inches from bottom of transformer tank and secured to transformer tank by a strapping design with shield above valve, in compliance with OSHA safety regulations. There shall be at least two stages of pressure reduction regulation in the inert gas system from the bottle pressure to the pressure in the transformer (settable down to 1.5 psig). The regulation equipment (not the Nitrogen bottles) shall be in a self-contained, weatherproof, steel cabinet. Removal and replacement of the regulator shall be readily accomplished. A pressure gauge (3000 psig) for monitoring the pressure in the gas cylinder shall be provided. The gauge shall be equipped with a contact to indicate 200 psig. A contact shall be wired to the terminals in the control.

The inert gas monitoring system shall be provided with the following gauges and alarms inside the cabinet. All alarm contacts shall be wired to an independent terminal block in the gas cabinet and brought to the alarm terminal block in the main control cabinet.

- Pressure gauge for monitoring the transformer tank pressure.
- A ball valve between the transformer tank and the gauge to allow calibration of gauge at site.
- A self-resetting low-pressure switch for monitoring the transformer tank pressure. The alarm contacts shall be set to close at 4 ounces per square inch of decreasing pressure in the main transformer tank and reopen at 6 ounces per square inch increasing pressure.
- A transformer high-pressure alarm switch for monitoring the transformer tank pressure.
- The alarm contacts shall be set to close at least 1.0 psig below the maximum rated tank operating pressure.

5.3.15.15 Valves, Pipes and Hardware

All valves shall be flange mounted. All valves shall have provision for padlocking. The transformer shall be provided with the following valves and fittings for oil filling and processing:

- Oil drain valve. (with ¼ inch oil sampling valve)
- Vacuum pump connection.
- Oil filling connection with oil deflectors inside the tank.

An “oil supply valve” and an “oil return valve” – shall be provided on the transformer tank for connection to a “Dissolved Gas in Oil” monitoring system. The valves shall be 1-1/2 inch NPT gate valves with a plug. The oil supply valve shall be located near the radiator top header and the oil return valve shall be located near the transformer tank base. Distance between these two valves shall be not less than three feet. Both valves shall be located as close to the control cabinet as practical.

Appendix 1: Collector Substation

5.3.15.16 Bushings and Terminals

All bushings shall be in accordance with IEEE Std C57.19.01 with the rated voltage and minimum BIL as tabulated below.

Table 20: BIL and Voltage Ratings for GSU Bushings and Terminals

Nominal System Voltage (kV)	Rated Voltage of Bushing (kV)	Rated BIL of Bushing (kV)
500	318	1675
345	220	1175
230	146	900
161	146	750
138	102	650
115	88	550
69	44	350
34.5	22	200
24	16	150
13.8	10	150

The rated current of the bushing shall be as specified in IEEE Std C57.19.01 but not less than 1.2 times the transformer load current corresponding to its maximum MVA rating with full cooling in operation.

All bushings including the neutral bushing shall be provided with test taps.

All bushings shall be power factor tested. Values of “C1” and” C2” shall be stamped on the bushing nameplates.

The oil sight gauges or sight glass on cover-mounted bushings shall face “outward” so that the oil level sight glass in the bushing can be seen from ground level. All bushing nameplates are to face outward to allow reading of nameplates with spotting scope.

All bushings shall be paper-oil condenser type. Minimum clearance between the live parts of bushings and surge arresters to the components of the transformer that may be serviced (e.g. gas detector relay, valves, gauges, etc.) shall be in accordance with OSHA requirements. Bottom of the bushings shall be minimum 8.5 feet above ground including six-inch foundation pad. Vertical clearance between the bushing terminal and the ground shall be in accordance with National Electrical Safety Code IEEE Std C2 requirements.

Bushings shall have the creepage distance set forth in Table 21.

Appendix 1: Collector Substation

Table 21: GSU Bushing Creepage Distance

System Voltage (kV)	Creepage Distance (inches)
15	15
25	25
35	35
69	69
115	115
138	138
161	161
230	230
345	345
500	415

All bushings shall be supplied with NEMA standard 4-hole, four-inch square stud connector terminal pads, machine-finished and tin plated on both sides. The H2 and X2 bushings shall be located on the same centerline, and where practicable shall be on the main tank centerline.

Minimum metal to metal clearance between the live parts of bushings in the air shall be as tabulated below in *Table 22*.

Table 22: GSU Bushing Minimum Clearance Between Live Parts

System Voltage (kV)	Clearance (phase to phase) (inches)	Clearance (phase to ground) (inches)
Up to 34.5	24	15
69	32	26
115	48	41
138	60	49
161	72	56
230	90	67
345	120	100
500	160	150

5.3.15.17 Bushing Current Transformers

Internal, multi-ratio, bushing-type current transformers shall be provided with all secondary terminals wired to shorting terminal blocks using ring type lugs without intermediary splices.

CT ratios shall be based upon full load current through the bushing(s). Typical CT ratios are listed below in Table 23. Actual ratios to be confirmed as required to support protection relaying scheme requirements and shall be submitted for Buyer's written Buyer approval. For 345 kV and 500 kV voltages, requirements will be provided under separate cover.

Appendix 1: Collector Substation

Table 23: GSU Bushing Typical CT Ratios

BUSHING VOLTAGE (kV L-L)	kV	600:5	1200:5	2000:5	3000:5	5000:5	XFMR WINDING MVA RATING: 3Ph @65C	
	13.8	12-14 MVA	19-28 MVA	28-47 MVA	47-71 MVA	71-100 MVA		
	14.4	12-14 MVA	19-29 MVA	29-49 MVA	49-74 MVA	74-100 MVA		
	24	12-24 MVA	33-49 MVA	49-83 MVA	83-100 MVA			
	34.5	12-35 MVA	48-71 MVA	71-100 MVA				
	69	12-71 MVA	95-100 MVA					
	115*	12-100 MVA						
	138*	12-100 MVA						
	161*	12-100 MVA						
	230*	12-100 MVA						

Note: CT ratio should be appropriate such that CT saturation is taken into consideration for project specific fault currents.

The continuous thermal current-rating factor for the bushing current transformers shall be 2.0 based on temperature rise in accordance with IEEE Std C57.13 unless specified otherwise in this Appendix.

All current transformers shall be multi-ratio with ratios in accordance with IEEE Std C57.13. All secondary leads shall be brought to the control cabinet. All secondary leads for each CT shall be terminated and individually identified, at individual short circuiting terminal blocks, equipped with a shorting bar that permits each terminal to be shorted to the other when a set screw is inserted. CTs that are spare and do not have any connected secondary load shall be short circuited with temporary yellow shorting wire jumpers on Customer side of terminal block, in addition to the set screw. Sole use of shorting set screw is not acceptable. exterior CT leads shall be protected in schedule 40 aluminum, or hot-dipped galvanized steel conduit. This conduit shall not be shared for other wiring.

Provision shall be made to remove and replace the CTs without removing the tank cover.

5.3.15.18 Surge Arresters

Surge arresters shall be station class silicone polymer. Energy class of surge arresters for application up to system voltage 245 kV shall be class "F", and for application at 362 kV and 500 kV shall be class "G" in accordance with IEEE Std. C62.11.

Appendix 1: Collector Substation

Table 24: GSU Arrester Ratings for an Effectively Grounded, wye connected system

System Voltage (kV)	Surge Arrester Rated Voltage (kV)	Surge Arrester MCOV (kV)
500	420 kV	335 kV
345	276	220
230	192	152
161	132	106
138	120	98
115	96	76
69	60	48
34.5	30	24.4
24	21	17
12.47-14.4	12	10.2
4.16	6	5.1
2.4	3	2.55

Arrester ratings for an Ungrounded or Impedance Grounded, Delta connected system shall be provided on a project basis and require approval by the Buyer.

The height, from base to the terminal, of the arresters up to 34.5 kV shall be the same as that of the associated LV bushing to reduce probability of flash cause by wildlife. Spacers should be added at the base of the arresters if necessary.

Each arrester shall be individually grounded.

5.3.15.19 Cooling System

The transformer shall be provided with two stages of cooling using forced air circulation ONAN/ONAF/ONAF).

Connection provisions shall be made in the cooling equipment controls circuit to allow external interlocking with the transformer protective relaying scheme, such that operation of normally closed contacts of the transformer protection lockout relay (86T) will shut down the cooling equipment in the event of an internal transformer fault.

5.3.15.20 Fans

The fans shall have a one-piece, heavy duty, dynamically balanced metal blade. Sheet metal or plastic blades are not acceptable.

Fan motors shall be NEMA type, totally enclosed, outdoor weatherproof with sealed ball bearings.

Unless specified otherwise in the purchase requisition the motor voltage shall be 230 Vac, single-phase, 60Hz. Plugs for all unused fan motor weep holes shall be provided.

Fans shall not be located on top of the radiators nor directly mounted on radiator fins. Separate, removable mounting support for fans shall be supplied and bolted to the transformer tank.

Fan guards shall be hot-dipped galvanized, totally enclose the fan blades, and meet OSHA safety requirements.

Appendix 1: Collector Substation

5.3.15.21 Radiators

Radiators shall be detachable from the main tank and preferably shall be interchangeable. The radiators shall be equipped with bolted flanges and valves to permit the removal of any radiator without draining the oil from the transformer or any other radiator and without the loss of cooling from other radiator banks. Lifting eyes shall be provided on each radiator/cooler group.

Studs welded to the tank or headers for mounting of the radiators are not acceptable.

Radiator shut-off valves (butterfly type) shall be provided for each detachable radiator or header, at both top and bottom openings to the main transformer tank. It shall be possible to remove individual radiators for maintenance without the loss of cooling from other radiator banks. The open and closed positions on the radiator shut-off valves shall be clearly and marked.

Radiators shall be heavy hot-dip galvanized in accordance with ASTM A123. As measured in accordance with ASTM A386, minimum zinc-coating thickness shall be 3 mils or 1.8 oz/ft². If any repair of the galvanizing coating is necessary, Seller shall make such repairs in accordance with ASTM 780. Radiators shall be located about the main tank such that access to drain and fill valves, gauges, thermowells, manholes, etc., is not blocked.

5.3.15.22 Cooling Equipment Control

All protective devices, control switches and contactors, etc., required for the control of fans shall be located in the transformer control cabinet.

Winding temperature indicators/sensors shall be calibrated to simulate the winding(s) actual hottest spot temperature and shall actuate automatic control of the fans.

An alarm relay shall be provided for each stage for cooling failure.

A two-position "Fan Transfer Switch" shall be provided to allow selection of either bank of cooling equipment to operate on either stage of cooling.

A three-position switch shall be provided to allow manual or automatic operation of cooling equipment. Switch positions shall be marked "Auto-Off-Manual".

Each bank of cooling equipment shall be fed separately from and protected by a two-pole breaker of adequate rating, 20 kA interrupting capacity minimum.

Means shall be provided to turn off the cooling system with a remote contact.

5.3.15.23 Control Cabinets

Control cabinet(s) shall comply with the requirements of IEEE Std C57.148 except were modified by this specification.

All cabinets shall be of sheet metal, minimum 12-gauge thickness, weatherproof and sufficiently rigid to prevent warping of doors to ensure positive operation of doors and latches. The top of the cabinet shall be sloped to prevent water accumulation. A drip shield shall be provided above the cabinet door(s). Doors shall be hinged and shall have a heavy duty, handle-type three-point latch. All hinges, latches, etc. shall be made of stainless steel. Cabinets wider than four (4) feet shall have two approximately equal sized doors.

The inside pocket on the door shall contain one copy of the instruction manual and OEM drawing set.

All devices for the transformer control, indication, and terminal blocks for external cable connections shall be located in a weatherproof control cabinet. All control, power, CT, cooling system and alarm wiring shall be terminated in the control cabinet.

Appendix 1: Collector Substation

The bottom of the cabinet shall be approximately 24 inches above the foundation or the base of the mounting structure. Sufficient space and clearances shall be provided at the bottom of the cabinet to facilitate cable entry and termination.

All devices, switches, and pushbuttons that require routine access by Entergy shall be located not more than 60 inches above the foundation. Gauges in the cabinet shall be clearly readable from the ground.

All control cabinets shall be provided with heaters for anti-condensation. The heaters shall be rated to operate at 120 V ac and each heater shall be on its own circuit, protected by an appropriate 20 kA interrupting capacity circuit breaker. The heaters shall be Positive Temperature Coefficient (*PTC*) for temperature limiting heater(s) of sufficient size to prevent moisture condensation. Fan-less PTC heaters, where used, shall be oriented to facilitate convective air flow over their fins to maximize heat transfer.

A 120-volt, 15 Amp weatherproof convenience duplex receptacle with ground fault protection shall be provided on the exterior of the control cabinet. A circuit breaker for this receptacle shall be provided inside the cabinet.

The cabinet interior shall have a switched convenience light. Large cabinets shall have two switched convenience lights.

The cabinet shall be provided with a grounding bar for individually grounding current transformers, control cable shields, etc.

5.3.15.24 Auxiliary Equipment and Control Wiring

Exterior wiring shall be enclosed in schedule 40, hot-dipped galvanized steel conduit. PVC is not acceptable. Flexible water-tight metallic shielded conduit or oil-resistant rubber-jacketed cords may be used for short runs to permanently mounted devices

Control wiring terminal blocks shall be barrier type rated 600 Volts, 30 amperes for 10 AWG control wire. Screws, with locking device, shall be non-ferrous and corrosion resistant Philips fillister-head metal type. An additional 20% spare or extra terminations shall be installed within the control cabinet. All metal parts of the terminal block shall be nonferrous and corrosion resistant. All terminal blocks with voltage above 120V shall be fitted with insulating covers to prevent accidental contact.

Wires shall be terminated using solder-less, compression type insulated ferule, ring terminals. Double lugging (two wires in one connector) is not permitted. Connectors shall be rated for the wire size used. The use of shims to allow use of larger connectors is not acceptable.

All current transformer wiring shall be minimum number 12 AWG stranded copper and all other wiring except for instrumentation shall be a minimum number 14 AWG stranded copper. All wiring shall be insulated for 600 volts with 150 °C insulation.

All wiring and components, including relay coils, motor controls, etc., shall be minimum 600 Volts AC insulation class, where applicable. Circuit breakers shall be thermal-magnetic, and rated a minimum of 240 Volts ac.

Oil stops shall be provided where wiring enters a chamber exposed to oil vapor.

All devices shall be identified by suitable nameplates in English. Polarity, phase and tap identification shall be provided where applicable. Terminal blocks and all other devices shall be numbered in accordance with IEEE Std C37.2.

5.3.15.25 De-Energized Tap-Changer

A tap changer for de-energized operation is required for the transformer unless specifically requested otherwise. When supplied, the taps shall be full capacity with two plus and two minus 2½% steps in the

Appendix 1: Collector Substation

high voltage winding. The internal mechanism shall be readily accessible for inspection and repair without untanking from the top of the transformer.

The tap changer-operating handle shall be mounted on the side of the tank not more than five feet above the base and shall have provisions for padlocking in each tap position. Each tap position, as marked on the transformer nameplate, shall be clearly and permanently marked on the operating handle in either raised or recessed letters in metal.

The tap changer shall have heavy stationary and movable contacts with silver plating. There shall be no requirement for moving the contacts to prevent coking unless the position is changed. The instruction book shall contain instructions for movement of the tap changer to wipe the contracts if the position is changed.

5.3.15.26 Load Tap-Changer

When specified, a motor operated, vacuum-type load tap changer (*LTC*) shall be supplied. The LTC shall comply with the requirements of IEEE Std C57.131.

Unless specified otherwise the LTC shall have a range of plus-or-minus 10% in 32 - 5/8% steps with full MVA capacity on all taps above neutral position, and reduced MVA capacity on taps below neutral position.

The LTC rated current for power transformers shall be not less than the maximum winding current at its rated maximum load (2 stages of supplemental cooling).

The tap position indicator shall be located where it can be readable and re-settable from the ground level. LTC position indicator shall be visible when manually operating the LTC. The position indicator shall have markings to signify the normal and range extremes and be in accordance with IEEE Std. C57.12.10.

Each contact of the load tap changing equipment shall be capable of 500,000 electrical and mechanical operations at the top MVA rating of the transformer before requiring contact replacement. The contacts shall be easily accessible.

The load tap changing equipment shall be contained in a compartment separate from the core and coils to prevent mixing of oil. The following shall be provided in this compartment:

- a) LTC drain valve.
- b) Oil filter connection, top.
- c) Oil filter connection, bottom.
- d) Provision for a common connection between main tank and load tap changing compartment including selector compartment if separate from LTC compartment for pressure equalizing during vacuum filling process. External pipe nipples with caps are acceptable.

The hand crank for manual operation of the drive mechanism shall be operable while standing at the base of the transformer. The automatic or manual operation of the LTC shall be blocked if the vacuum interrupter fails to interrupt and transfer the load current during a tap change operation.

LTC control devices shall be housed in the transformer control cabinet. The following shall be provided for the LTC controls:

- a) Switch for Manual-Off-Auto control functions. A contact CLOSED when the selector switch is in either the "OFF" or "MANUAL" position shall be provided for the Purchaser's supervisory indication.
- b) Switch for Local-Remote control.
- c) Tap Position Indicator with Drag Hands.
- d) Tap position indication sending unit
- e) Operations Counter.
- f) Raise/Lower Switch.
- g) Automatic voltage control equipment.
- h) Terminal blocks for Purchaser's cable connection.

Appendix 1: Collector Substation

i) Heaters for anti-condensation

Each tap position indication sending unit shall be operated by the LTC drive mechanism and provide a digital or analog output for indication in the substation control room and for SCADA indication. A tap changer auxiliary contact, closed during tap changer travel, shall be wired to terminals in control cabinet for "tap change-in-progress" indication.

Test terminals shall be provided for adjustment of the voltage relay, reading of output voltage and for testing and calibration from an external power source.

Protective devices shall include an oil level indicator in the tap changer compartment with "high" and "low" oil alarm contacts.

The LTC motor and control circuit shall have a factory installed jumper on Purchaser's side of terminal block with a note on drawing stating: "Remove jumper before connecting the power supply for out-of-service testing of LTC".

LTC control panel shall be equipped with a white indicator light to be illuminated on neutral position only and to be labeled "neutral position".

The load tap changer compartment cover shall be suitably hinged and bolted to the compartment flange. The gasket material shall be one-piece nitrile rubber. Galvanized nuts, to prevent galling, shall be used to bolt the door.

Design of the diverter switch shall be such that it shall not stop in between steps if the motor supply is interrupted before the step is completed. The tap-changer mechanism shall cause the tap-changer to move one step only per operation. The equipment shall be wired to prevent stopping on an off-normal position due to inching.

LTC drive motor shall have thermal overload protection and means shall be provided for isolating the motor from the supply.

5.3.15.27 Nameplates

Nameplates shall be made of stainless steel, and permanently attached to the transformer tank(s) with appropriate hardware. Transformers shipped without nameplates attached to them will not be accepted by Entergy. Nameplates shall include permanently engraved data per IEEE Std C57.12.00. A schematic representation of main winding and current transformers connections shall be shown. Ratios and polarities shall be indicated for all CTs. Rated currents shall be shown for all windings. A table showing the rated current at the various tap voltages shall be provided for the ONAN and ONAF ratings of the transformer.

Location and rating of all internal voltage, and current limiting devices shall be shown.

5.3.15.28 Transformer Monitoring

The transformer shall be provided with an on-line monitoring system to continuously monitor the condition of LV and HV bushings, transformer dissolved gases and temperatures and other transformer parameters, including loss of insulation life. The on-line monitoring system shall be capable of controlling the coolers'/radiators' operation in parallel with the conventional cooler controls.

Buyer currently uses Dynamic Ratings Monitoring Control Communication (**DRMCC**) on-line monitoring with a bushing monitoring system. The latest DRMCC monitoring system or a better system approved by Buyer in writing shall be provided with the transformer.

The type and model of the on-line monitoring system and multi-gas monitoring for the transformer shall be specified in the bid proposal. The on-line monitoring system shall have communications protocols built in to monitor all parameters in Buyer's Distributed Control System (**DCS**) and PI data server. The transformer shall be provided with the latest model of a Vaisala multi-gas monitor (or better), to be specified by Seller and approved by Buyer in writing, for continuously monitoring and detecting fault gasses in the transformer

Solar BOT Scope Book: Appendix 1 Collector Substation

Appendix 1: Collector Substation

oil. The system shall be complete with necessary hardware, software, and interfaces. This gas monitor shall perform the following functions or as specified by Buyer: detect, analyze, and correlate quantity of all dissolved fault gasses, including hydrogen (H₂), carbon monoxide (CO), carbon dioxide (CO₂), methane (CH₄), ethylene (C₂H₄), ethane (C₂H₆), acetylene (C₂H₂) moisture-in-oil, and oil temperature.

The transformer shall include an annunciator/data logger panel in the transformer control cabinet. The type of annunciator/data logger shall be Rochester Instrument Systems Inc. (**RIS**) or equivalent approved by Buyer in writing. The annunciator shall monitor the system's health and indicate occurrences of alarms, trips, and other general signaling messages.

The annunciator shall be mounted on a hinged weather-tight panel, for easy access to rear wiring, in a cabinet of dead-front construction arranged so that water cannot enter the wiring area of the cabinet when resetting the annunciator in rainy or inclement weather. A plexiglass panel shall be provided for external viewing of the annunciator. The panel door shall be equipped with a handle mechanism to allow easy access to the annunciator.

The following is a typical list of alarms generated by the monitoring devices that the annunciator system shall be required to monitor and display. All alarms will be discussed and approved in writing during the design review meeting with Buyer.

- Power Supply Auto Transfer
- Loss of AC Control Power for each circuit.
- Fan bank motor current excessive
- Fan bank fail
- Cooling system breaker fail
- Low Oil Level
- Low-Low Oil Level
- Sudden Pressure Seal-in Relay
- High Top Oil Temp. 100° C
- High-High Top Oil Temp. 110° C
- High Winding Temp. 110° C
- High-High Winding Temp. 120° C
- Gas Detector Relay
- Monitoring Devices Fail
- Control Cabinet Temp. High
- Low Nitrogen Cylinder Pressure

Alarm contacts shall be Form C type and shall be wired independently to terminal blocks in the control cabinet to make possible any grouping of alarms by Buyer for remote indications. The contacts shall be rated 125 volts DC, 5 amps continuous and 0.2 amps DC non-inductive tripping.

Protection and Monitoring Devices:

The transformers shall be equipped with the following devices for monitoring, control, and protection of the transformer (all of which shall have independent alarm contacts wired to the terminal blocks in the control cabinet):

Oil Level Gauge:

A magnetic oil level gauge, Qualitrol or Buyer-approved equivalent, with a 6-inch dial, visible from the ground level shall be provided on the transformer tank and conservator.

The oil level gauge shall be a two-stage oil level monitor. Each stage shall be provided with two normally open contacts for alarm and trip functions. Contacts of the second stage shall close when the oil level in the transformer tank falls to a critical level and will result in an internal flashover of the unit.

Top Oil Temperature Gauge:

Solar BOT Scope Book: Appendix 1 Collector Substation

Appendix 1: Collector Substation

A conventional oil temperature indicator, Qualitrol or Buyer-approved equivalent, with a minimum six (6)-inch dial, with drag hands, shall be supplied to indicate the temperature of the top oil. The instrument shall be mounted at eye level. The indicator shall be vibration-insulated from the transformer. The temperature indicator shall have two adjustable normally open contacts. Top oil alarm contacts shall be set at 105°C and used to turn on all of the cooling equipment.

Pressure Relief Devices:

A spring-loaded diaphragm-type pressure relief device, Qualitrol Type XRPD or Buyer-approved equivalent, complete with animal intrusion screen P/N SCN-600-1 and a DPDT alarm contact shall be mounted on the transformer tank cover or the tank wall near the top. Transformer tanks containing more than 10,000 gallons of oil shall be provided with two pressure relief devices mounted on diagonally opposite corners of the transformer tank. The device(s) shall be located remote from the control cabinet(s) and equipped with directional shield to direct oil flow downward. Pressure relief value shall be stamped on the device.

Sudden Pressure Rise Relays:

A transformer with conservator tank shall be equipped with two sudden pressure rise relays, Qualitrol Type 900-014-02, to detect rapid pressure increase in the transformer tank. The relays shall be located on diagonally opposite corners of the transformer and shall be flange-mounted with gate-type shut-off valves located between three (3) and six (6) feet above the base of the transformer.

Sealed tank transformers shall be supplied with two sudden pressure rise relays, Qualitrol Type 910, to detect rapid pressure increase in the transformer tank. The relays shall be flange-mounted with gate-type shut-off valves in the gas space on the tank wall.

The sudden pressure relays shall be provided with Qualitrol type 909-300-01 seal-in relays set up for 125 volts DC and reset feature. A target relay shall be provided to give visual indication of sudden pressure relay operation. The target relay shall also have a reset feature. The alarm and trip contacts of the relays shall be wired to the terminal blocks in the control cabinet.

Actuation of each relay will result in an alarm. Actuation of both relays will result in a unit trip.

Gas Accumulation Detecting Relay:

The transformers with a conservator tank shall be equipped with a gas accumulation detection device for detecting the presence of combustible gas within the tank and auxiliary oil-filled compartments. The device shall be Qualitrol type 038-003-01 complete with a sampling valve and alarm contacts. Sample test valves shall be located a maximum of five (5) feet above the transformer base.

The design of the gas detecting system, showing the location of the gas detection device and the gas accumulation system, shall be submitted for Buyer's written approval before manufacture. Seller shall also submit a complete written description of operation as applied to the particular transformer with above submittal that will later become part of the Instruction Book.

A Buchholz gas monitor relay shall be installed based on the transformer design with the Constant Oil Preservation system (**COPs**) tank.

Dehydrating Breather(s):

The oil preservation system of transformer with a conservator shall be equipped with a Waukesha/HVS, or Reinhausen or other Buyer-approved, automatically self-regenerating, maintenance-free dehydrating breather containing an oil bath to prevent outside air from having direct contact with the desiccant.

Top of the breathers shall be within approximately five feet of the transformer base.

Temperature Monitoring System:

Transformer shall be provided with an Electronic Temperature Monitoring System (**ETMS**) in which the temperature rise of the winding hottest spot over the top oil temperature is added digitally by calculation.

Appendix 1: Collector Substation

The traditional simulated winding hotspot measuring system consisting of winding temperature CTs, heater circuit, and analog dial type thermometers is to be supplied only when specifically requested in the purchase order.

The transformer shall be provided with sufficient number of winding temperature CTs, thermo wells, sensors, dual element RTDs (Pt100Ω or Cu10Ω), probes, etc., to monitor the transformer oil and winding temperatures using a digital temperature monitoring system. The transformer shall be equipped with an APT TTC-1000 from Advanced Power Technologies or Buyer-approved temperature monitoring system with digital displays easily readable in daylight.

The sensors, probes, thermowells, etc., shall be located on the transformer tank sidewall (not the tank cover), and capable of being installed or replaced without de-energizing the transformer, opening the transformer, or lowering the oil in the transformer.

The ETMS shall have the digital displays for the following:

- HV winding hottest spot temperature, each phase
- LV winding hottest spot temperature, each phase
- Transformer tank top oil
- Transformer tank bottom oil
- Ambient temperature
- Control cabinet temperature

The temperature monitor shall have large Light-Emitting Diode (**LED**) displays for easy readability in any lighting condition. The monitor shall operate with a solid-state LED light source that will under normal operating conditions last for the life of the transformer without the need to replace the light source.

The monitor shall cover a temperature range from -30 °C to +150 °C, and shall have a display resolution of ± 1 °C and a 0.7% accuracy at full scale. The device should display the future temperature gradient projection and the load current. The monitor shall be complete with 4–20 mA analog outputs for oil temperature and winding temperature and have contacts to control cooling, for alarms, and for trips.

The monitoring system with digital display gauges shall be mounted in the control cabinet five (5) feet above the base of the transformer. The temperature monitor shall be installed in a manner such that all controls are visible and adjustable from the front, and such that adjustments may be made without interference to other devices. The monitor shall be labeled as ETMS.

The transformer shall be provided with sufficient number of windings embedded fiber optic sensors at least three (3) fibers per phase per winding (HV & LV) for winding temperature monitoring and three fibers for top oil temperature monitoring. The fiber shall be terminated into Luma Sense digital temperature monitor or Buyer-approved equivalent located inside the control cabinet. The temperature monitor shall have outputs to connect to other plant devices, DCS, and monitors, including the transformer on-line monitoring system.

5.3.15.29 Tests

The Manufacturer shall notify the Purchaser at least four weeks in advance when planned specified tests are to be conducted and at least two weeks in advance when the tests dates are firm. The Purchaser reserves the right to inspect and witness these tests at the factory.

The insulating oil used to fill the transformer for the purpose of performing the electrical tests shall not be lowered, replaced, or otherwise altered, nor shall the access cover be removed at any time throughout the duration of the testing. All tests shall be performed on the fully assembled transformer including cooling and conservator equipment. The bushings that will be furnished with the transformer shall be installed on the transformer during the factory tests. Substitute bushings for testing shall not be allowed.

Appendix 1: Collector Substation

Resistance, polarity, ratio, phase relationship, impedance, load loss and temperature rise test shall precede the dielectric tests. No-Load loss and excitation current tests shall be performed after impulse tests. A final Dissolved gas-in-oil analysis (DGA) shall be performed before and after the temperature tests and before and after the dielectric tests.

All transformers shall be tested in accordance with IEEE Std C57.12.00.

- Resistance measurements shall be taken at all DETC tap positions. For three phase windings phase to phase and per phase values shall be recorded and reported.
- Lightning impulse tests shall be performed on all transformers. All terminals including neutral shall be tested.
- The temperature monitoring equipment shall be operational during temperature rise tests and demonstrated during these tests. For the transformers equipped with fiber optic temperature sensor probes, the hottest probes for each phase shall be identified. Temperature data for all probes shall be recorded and reported in the test report. If the Manufacturer's calculated values for the top oil and hot spot temperature fall below the fiber optic thermometer measurements the Manufacturer shall determine the cause and may be required to repeat the temperature rise test. Temperature rise test results shall include steady-state (prior to hot-resistance takeoff) readings of top-oil and winding hot-spot temperatures from gauges and electronic temperature monitors. The reported hot-spot reading may be after any calculated adjustment for the tested versus calculated average winding rise.
- A temperature rise test in accordance with IEEE Std C57.12.90 shall be performed on the first unit of a design. The test shall be conducted at the base ONAN rating and at the maximum ONAF ratings. The temperature rise test shall be performed prior to the dielectric testing. Ambient temperature, top and bottom oil temperature rise, average winding temperature rise and winding hot-spot temperature rise shall be stated on the test reports. Test report shall include oil and winding temperature readings from the electronic temperature monitor and infrared images of transformer sides and cover for the maximum ONAF test.
- Dissolved gas-in-oil analysis tests shall be performed before, during, and after each temperature rise test. Oil samples shall be taken at the start, and at the completion of the tests, within one hour of the final shutdown. The rate of generation of the gases shall not exceed the limits proposed in IEEE Std. C57.130.
- Bottom oil temperature rise shall be included in the test report.
- Partial discharge measurements using the apparent charge method for power transformers rated 69 kV and above, shall be recorded. The partial discharge shall not exceed 200 pC. The increase in the partial discharge during the one-hour test shall not be more than 30% of the reading taken ten minutes after the enhancement tests. The partial discharge level during the enhancement period shall be recorded and included in the test report. All units shall be tested.
- Transformer turns ratio test shall be performed at each HV tap to neutral and from rated HV tap to all LTC positions (as applicable).
- When specified, audible sound level tests shall be conducted.
- Excitation current and no-load losses shall be measured at 90, 100, 105, 110 and 115 percent of rated voltage.
- Impedance and load loss measurements shall be made at the normal tap and the tap extremes, at the self-cooled ONAN rating of the transformer using three wattmeter method and corrected to 85 °C.
- Insulation power factor measured prior to starting the tests shall be 0.4% or less when converted to 20 °C. The measurements shall be made using DOBLE or other Entergy approved equivalent test equipment. The test form shall be submitted before, or to coincide with, the transformer shipment.
- All bushings shall be tested in accordance with IEEE Std C57.19.00. The partial discharge shall not exceed 10 pC or 10 μ V in accordance with IEEE Std C57.19.01. Power factor tests shall be performed on all bushings with resulting power factor and values of C1 and C2 recorded in the test

Solar BOT Scope Book: Appendix 1 Collector Substation

Appendix 1: Collector Substation

report. Copies of the certified test report from the bushing manufacturer shall be included in the transformer certified test report. The Manufacturer shall verify that all bushings have also been tested utilizing Doble or approved testing equipment.

- Pressure test on the tank and the cooling system shall be made by filling the transformer with hot oil and maintaining 10 psig pressure maintained for 10 hours. If any leaks appear they shall be repaired, and the test shall be repeated.
- A vacuum test shall be performed on the transformer tank and cooling system designed for vacuum filling.
- Current transformers shall be tested as required by IEEE Std C57.13. Polarity applied potential tests and saturation tests shall be repeated after installation of the CTs in the power transformer from their terminals in the control cabinet. The following tests are required:
 - Applied Potential Test.
 - Induced Potential Test.
 - Polarity Test.
 - Saturation Curve.
 - DC Resistance.
- The results of calibration tests on the winding temperature devices (hot spot indicators) shall be included in the test report. The test report shall include the tap setting of the correcting transformer, if used, when calibrated.
- Zero sequence impedance tests shall be performed. For three winding transformers the impedance between each pair of windings shall be measured, i.e., HV-LV, HV-TV, LV-TV. Zero sequence test is not applicable to single phase units.
- Core to Frame insulation tests shall be made, with minimum 1000-volt insulation tester, and recorded on the completed core and coil assembly prior to the tanking of the assembly. Core insulation tests shall be repeated after the transformer is loaded on the carrier immediately prior to shipping. The measured resistance and voltage of the tester shall be shown in the test report.
- The correctness of the control wiring shall be checked by electrical operation of all devices and individual circuit continuity checks by electrical circuit testers. The control wiring and current transformer wiring insulation shall be tested as required by IEEE Std C57.12.00, and IEEE Std C57.148.
- Doble SFRA tests shall be performed on all transformers in the oil-filled fully assembled condition. For transformers that are shipped by ocean vessel or rail, additional SFRA tests shall be performed in the as-shipped condition using spark-plug type bushings on the bushing shipping covers. These test bushings shall be protected during shipment.
- All certified test reports shall require approval by Entergy prior to shipment. The test reports shall include a brief statement of any test failures or abnormalities that required repair and retesting of the transformers.
- The manufacturer shall provide Doble power factor and SFRA files for both factory and field (install) testing.
- Nameplate data for all bushings tested and scheduled to be shipped with the transformer shall be supplied in the certified test report.

5.3.15.30 Approval Drawings

All drawings for approval shall be sent under a cover letter which lists drawing numbers and title of all drawings forwarded, destination of the transformer, and Customer purchase order number.

The following drawings shall be submitted for approval; within 6 to 8 weeks after receipt of a purchase order from the Purchaser.

- Outline and General Assembly - this drawing shall show details such as dimensions, weight, location of accessories, handholds, manholes, center of gravity, lifting and moving details, etc.
- Bill of Material - this shall include but not be limited to the following:

Solar BOT Scope Book: Appendix 1 Collector Substation

Appendix 1: Collector Substation

- Manufacturer, rating, type and creepage distance of bushings
- Type and catalogue number of connectors when supplied Manufacturer, type, and catalogue number of accessories, e.g., gauges, pressure relief devices, indicators, breathers, etc.
- Manufacturer, type, catalogue number, size and material of valves, pipes, and fittings
- Manufacturer, quantity, rating, and capacity of fans
- Type, catalogue number and manufacturer of all components including control switches, terminal blocks, fuses, instruments, and relays in the control cabinet
- Nameplate Diagram – the nameplate drawing shall show the transformer serial number.
- Schematic diagrams
- Wiring Diagrams – shall be point to point drawings. Line-less, wire list and coordinate type drawings are not acceptable.

5.3.15.31 Generator Step-Up Transformer Warranty

The GSU transformer(s) shall be provided with an original equipment manufacturer's warranty that the GSU transformer(s) shall be free from defects in material, manufacture, workmanship, and design for a minimum period of five (5) years from the date of such GSU transformer's energization; provided that, if such GSU transformer has not been energized within six (6) months after delivery thereof to the Project Site, the warranty period shall be at least five (5) years commencing twelve (12) months after the date of delivery to the Project Site. The GSU transformer manufacturer shall be required to repair or replace at its cost any GSU transformer (or component thereof) in breach of such warranty. The warranty shall cover the cost of removal from the Project Site, transportation to and from the repair facility, reinstallation after repairs, and any and all other "in and out" work.

Seller shall notify Buyer of any procedure, activity, or other Work that may void a manufacturer warranty or violate any law or applicable permit reasonably in advance of the performance of such procedure, activity, or Work. Seller shall provide to Buyer all original equipment manufacturer warranty documents.

5.4 Neutral Grounding Reactor

The Neutral Grounding Reactor (*NGR*) shall be used to limit the fault current magnitude on the 34.5kV.

The rating of the NGR shall be based on underground collection design, short circuit analysis and ampacity calculation design criteria. *Table 17* shows typical MPT MVA where the X0 Neutral Grounding Reactor is required. The requirement of the NGR shall be evaluated during planning phases.

5.5 Station Service Transformer (Auxiliary Loads)

All HV substations, and other major and strategic substations, shall be provided with two independent AC station service sources with automatic transfer from one source to the other for redundancy.

Recommended station service AC voltage ratings are as follows:

- 240/120 V AC 60Hz, single phase, 3 wire.

The AC station service capacity shall be sufficient to supply all loads for the following, as applicable:

- Control house lighting, heating, and air conditioning,
- Power transformer cooling fans, pumps, LTC and control cabinet space heaters,
- Circuit breaker control cabinet heaters, and operating mechanism charging motors,
- Substation lighting,
- Battery chargers
- Maintenance equipment, including gas cart, and oil filter truck if feasible

Solar BOT Scope Book: Appendix 1 Collector Substation

Appendix 1: Collector Substation

- Future loads

Approved sources of AC station service include the following:

- Distribution line(s) area feeder
- Distribution transformer connected to a substation bus
- Station Service Voltage Transformers (**SSVTs**) up to 230 kV (suitably rated for this service, but not less than 50 kVA)

SSVTs are used as the primary station service source in critical substations or in substations up to 230 kV without a MV source. The backup station service in such substations shall be from a nearby area distribution feeder based on economics and station importance. If a distribution feeder is not available, then a second SSVT shall be used as a backup. The SSVTs shall have sufficient kVA rating to be able to supply all substation loads including maintenance equipment.

SSVTs are typically connected to the substation bus or a transmission line and are within the associated primary protection zones. Surge protection shall be required on the HV side of the SSVT unless arresters protecting other equipment are close enough to protect the SSVT.

Alternate sources of AC station service, including but not limited to the following, are to be used only in special circumstances and require Buyer's approval:

- Inverter system
- Solar panels
- Autotransformer tertiary
- SSVTs above 230kV

An engine generator shall not be acceptable for providing AC station service source.

See IEEE Std. 1818 -IEEE Guide for the Design of Low-Voltage Auxiliary Systems for Electric Power Substations for additional guidance.

5.6 Reactive Equipment

Reactive equipment used to provide power quality and reliability to the electrical system (where required) shall be done through capacitor banks and reactors at the 34.5 kV level. To protect and control the reactive equipment, a circuit/reactor switcher shall be used. The MV circuit breaker (See Section 5.3.14.3 (Medium Voltage: Collector Feeders and Reactive Breakers:)) shall be used to protect for external faults of the reactive zone of protection (bus differential, etc.)

5.6.1 Circuit Switcher

Fully rated dead tank circuit breakers shall be used for the switching of power transformers and shunt capacitor banks; however, circuit switchers may be used with Buyer's prior written approval. For switching of the shunt capacitor banks rated up to and including 170 kV, the circuit switchers shall be equipped with pre-insertion resistors for suppression of transients.

For each application where a fully rated dead tank circuit breaker is not justifiable and circuit switcher with a desired fault interrupting rating is not available, a live tank circuit breaker without post type instrument current transformers may be considered in lieu of circuit switcher with Buyer's prior written approval.

Circuit switchers are typically rated to interrupt lower fault currents than circuit breakers. As the circuit switchers are normally installed to protect shunt capacitor banks, they are designed to be rated to the expected capacitive switching current as mentioned in the IEEE standards. The circuit switcher application shall ensure that these ratings are not exceeded.

Appendix 1: Collector Substation

5.6.2 Shunt Reactors

Air core reactors present unique design and safety considerations because they produce very high magnetic fields during normal operation. The distance from adjacent iron and steel structures and apparatuses must be sufficient to prevent induction heating. Safety fencing with reactor safety signage shall be provided as needed to prevent personnel from getting too close to a set of reactors. A worker approaching too close could experience overheating of ferrous items he is carrying. There is a danger that implanted medical electronic devices such as pacemakers, insulin pumps, or hearing aids will malfunction or fail, causing injury or death. The manufacturer's documentation shall include minimum phase spacing and magnetic clearance requirements for perimeter fencing and these requirements shall be adhered to in the design of the substation.

The Substation Designer shall consult with the manufacturer of the reactors with any additional questions including clear instructions for reactor grounding. To protect personnel working near the reactors the Substation Designer shall also request the manufacturer to supply magnetic field plots, needed to determine the perimeter fence spacing.

The ratings of the shunt reactors shall be provided during detail analysis (Project specific not required in all projects).

5.6.3 Shunt Capacitor Banks

Shunt capacitor banks may be installed in ungrounded wye configuration up to 115 kV and shall be grounded wye for 138 kV and above. Fuseless capacitor units shall be installed in capacitor banks. Seller must obtain Buyer's approval in writing for any exception.

The ratings of the shunt capacitor banks shall be provided during detail analysis (project specific not required in all projects).

5.7 Control House

5.7.1 General

There shall be no wood framing or trim. Eave height is to be manufacturer's standard to accommodate a clear interior height of 10 feet (minimum) including specified insulation.

See Section 8 (FOUNDATIONS) for control house structural design information.

5.7.2 Roof

All roof panels in all locations shall have a U.L. wind uplift classification of class 90 (minimum).

5.7.3 Ceiling

Insulation shall be R-19 minimum and shall have a U.L. Flame Spread Rating of 25 (minimum).

5.7.4 Walls

For metal buildings, the exterior building walls shall be constructed with a minimum of 16-gauge aluminized steel (or a zinc-aluminum finish), flat or corrugated surface, with a factory baked on light reflecting finish including a minimum ten-year guarantee.

For concrete buildings, the exterior building walls shall be solid concrete design with 6-inch walls and steel rebar reinforced high strength concrete.

Appendix 1: Collector Substation

The building walls shall be insulated with a non-combustible blanket type insulator with a glued-on vapor barrier facing material rated at R-11 (minimum) and a U.L. Flame Spread Rating of 25 (minimum).

5.7.5 Doors

Substation control house doors shall be level 3 full flush doors (Level 3 - 16 gauge per ANSI/SDI A250.8-2003) with weather stripping. All doors are to be equipped with metal, weather-tight thresholds.

The main room (relay room) exit door shall be 6 feet wide (double leaves, 3 feet each). The battery room entrance and exit doors shall be 3 feet wide.

All doors shall be 8 feet in height. All exit doors shall open outwards and be equipped with panic bars and lighted or photo luminescent exit signs.

The battery room outside exit door shall have no outside handle and shall only be capable of being opened from the inside. All battery room doors (entrance and exit) shall have an emergency push bar. In the battery room, the floor and all interior wall panels shall be acid resistant.

5.7.6 Paint

For steel buildings, steel shall be coated with either aluminum or aluminum-zinc mix (containing at least 4% aluminum) and shall conform to the proper thickness as specified by ASTM. All structural steel is to have two shop coats of red oxide paint which meets or exceeds Federal Specification TT-P686.

5.7.6.1 Color Schedule

Exterior wall panels:	Light gray unless specified otherwise by Entergy
All trim:	As specified by Entergy (specified during planning phases)
Interior wall panels:	White
Ceiling panels:	White
Partition door:	White
Exit doors:	to match exterior trim
Interior partition wall:	White

5.7.7 Cable Tray

The tray shall be aluminum, ladder type, two side rails, with six inch rung spacing.

All cable tray entrances into the house shall be 36 inches wide and reducers shall be utilized to connect to 24-inch cable tray inside of the control house when required. A minimum of four (4) cable tray entrances is required.

A solid flanged aluminum tray cover (0.040 inches thick) with heavy duty cover clamps and stainless-steel mounting hardware shall be installed over all cable trays located on the outside wall of the control house.

Separate cable tray for communication cables shall be provided.

5.7.8 Lighting

Interior lighting shall be LED light fixtures that provide 40 foot-candles of light at a level of three feet above the floor.

External lighting shall be supplied above the exterior doors using weatherproof fixtures.

Exit lighting (OSHA-approved) shall be an LED illumination or self-illuminating device.

Appendix 1: Collector Substation

5.7.9 Air Handling

The battery room exhaust fan shall be rated for 90 cfm. Battery room exhaust fan(s) shall be equipped with animal deterrent and mounted 8 feet above the floor for security purposes. Exhaust fan(s) shall be controlled and operated with an electro-mechanical timer. Operation intervals of exhaust fan shall be a minimum of four twenty-minute cycles every twenty-four hours.

The air conditioner shall be controlled by a remote low voltage heating/cooling control thermostat, such as Accustat Energy Guard or equivalent, with design set points of 78°F for cooling and 68°F for heating.

5.7.10 Warranty

Building finish: minimum twenty (20) year non-prorated warranty.

The walls, including all wall openings for doors and louvered openings, are to be warranted weather-tight for a period of five years from the date of completion of the building.

Ceiling: minimum ten (10) year warranty.

Roof: minimum twenty (20) year non-prorated warranty.

A full five-year warranty on the control house including equipment with parts and service is to be included.

5.8 Substation Civil/Structural Design Criteria

Seller shall complete all civil works to furnish a Collector Substation site design, access road(s), and any other outdoor civil works required inside the Project Site or as needed for interconnection of the Project to the ELL Transmission System. The design shall meet all applicable federal, state, and local Laws and regulations and requirements of the Agreement, including the Scope Book and this Appendix 1, and provide a relatively maintenance-free design (e.g., provide adequately sized culverts to limit the possibility of clogging, provide erosion control means on slopes to eliminate maintenance re-grading, design access road cross-section to minimize rutting, etc.).

5.8.1 Siting and Civil

5.8.1.1 Flood Risk Evaluation

Flood risk shall be evaluated, and an Elevation Basis selected. This includes evaluation of the flood risk to the substation from rain, river elevation, storm surge, or other causes. It also includes the placement of structures within known Federal Emergency Management Agency (**FEMA**) Special Flood Hazard Areas (**SFHAs**) or other flood prone areas.

The substation location flood evaluation and decisions made with respect to site and equipment elevations shall be documented on the applicable substation site and foundation drawings.

The process to establish the Elevation Basis shall be as follows:

1. Determine if the site location is located within or near a FEMA SFHA.
2. If published information is available, determine the Base Flood Elevation (**BFE**) of the proposed site and if the location is within or adjacent to a mapped floodplain.
3. Evaluate the FEMA Flood Insurance Rate Map (**FIRM**) to determine the most recent revision to the map (including Letters of Map Revision).
4. Determine the date of the underlying Flood Insurance Study (**FIS**), if the FIS is available, and if the FIS method can be determined.

Appendix 1: Collector Substation

5. Evaluate local development and the potential impacts to flooding since the publication of the FIS.
6. Obtain written documentation about local ordinances regarding development in a SFHA, including any local requirements for development.

For locations outside of a mapped SFHA, but that are suspected to be at an elevated flood risk, document the known information and attempt to quantify the risk in relation to the site. An example of this type of risk evaluation is floodway extents or floodplain extents ending in a straight line in the vicinity of the site. This occurrence might indicate a road or railway embankment but may be indicative of an arbitrary study limit.

Determine planned access routes to the site for construction, operation, and maintenance and if such routes could be adversely affected by surface water flooding. The evaluation should consider the probability of surface water flooding at critical elevation points such as control houses, equipment cabinets, and access roads for the expected life cycle of the facility.

If the site is located within a FEMA SFHA, the underlying FIS was conducted within the previous 10 years, and the 100-year BFE is available, the 100-year BFE shall be used as the Elevation Basis.

If the site location is not located in a FEMA SFHA, the FIS was conducted more than 10 years ago, or the BFE is not otherwise available, engineering judgement and input from the Project Team shall be utilized to determine if local knowledge will be used as a basis for the site and equipment elevations or if a hydrologic and hydraulic study by a suitably experienced individual or company would need to be performed to determine an Elevation Basis. If it is deemed a study is needed to determine a proper Elevation Basis, a study should be ordered along with a site topographic survey. If applicable, the study shall be used to determine the Elevation Basis.

5.8.1.2 Flood Design Requirements

The Finished Grade of the site shall be at or above the Elevation Basis. Equipment foundation Top of Concrete (**TOC**) elevations shall be a minimum of one (1) foot above the Elevation Basis and a minimum of six (6) inches above the Finished Grade. The final TOC elevations shall be chosen to keep all equipment control cabinets a minimum two (2) feet and if possible four (4) feet above the Elevation Basis. The Project Team will determine the Elevation Basis, make the final TOC elevation determination, and document those determinations. The TOC elevations shall be recorded on the station foundation plan and foundation details.

When establishing the TOC elevation for the control house foundation, the relative elevations of the control house and equipment control cabinets shall be evaluated. In all stations the control house floor shall be a minimum of six (6) inches above the Finished Grade to prevent rainwater from entering the house. If the control house has trenches in the floor, then the bottom of the trenches shall be a minimum of six (6) inches above Finished Grade. In stations within a FEMA SFHA or otherwise determined to be prone to flooding, the control house floor should be at or above the elevation of the bottom of the lowest equipment control cabinet. A higher control house elevation may be selected to allow for easy maintenance access under the house. In existing substations where the control house is raised due to flooding concerns, the ability to raise equipment cabinets to the same elevation as the control house floor should be evaluated for feasibility.

5.8.1.3 Earthwork

The existing site shall be cleared, grubbed/stripped to a depth sufficient to remove organic material, leveled, filled, compacted, and sloped to drain. The substation yard shall be graded to accommodate drainage. The preferred substation site shall be graded with a slope of no less than 0.5% - 1.5% to facilitate water drainage from the site, storm sewers, catch basins, and/or manholes may be used if required for proper drainage.

Appendix 1: Collector Substation

A soil drainage analysis may be performed at the same time as soil boring investigation to determine the site's characteristics for water infiltration and retention for sites with aggregate implications larger than 1 acre where Governmental Authorities may require additional site Permitting.

The drawings shall note the control points on the site, and which coordinate system is to be used.

5.8.1.4 Erosion Control

The design shall comply with the Storm Water Pollution Prevention Plan (**SWPPP**) and Environmental Management Plan (**EMP**).

5.8.1.5 Wetland Delineation and Mitigation

Seller shall comply with all wetland requirements specified by Laws and applicable Permits. Wetlands shall be confirmed by a qualified third party.

5.8.1.6 Stormwater Management

Seller shall design the Project Site stormwater management plan. Seller shall complete and submit all necessary Permitting applications, including stormwater discharge National Pollutant Discharge Elimination System (**NPDES**) Permit applications, to the appropriate Governmental Authorities. The design shall provide for quality control of stormwater prior to discharge.

Seller's design for stormwater management on the Project Site shall meet stormwater quality and quantity requirements of local, state, and, if applicable, federal Governmental Authorities. The design shall consist of the following, as a minimum:

- Size and design details of stormwater, oil containment, run-off basin, and outfall
- Location and size of stormwater piping, inlets and manholes as needed
- Location and size of stormwater ditches or channels
- Project Site relative grades and slope including the drainage area to each stormwater feature

5.8.1.7 Site Surfacing

Thickness: The Project Site shall be graded to drain and then be surfaced with a minimum of six inches of compacted crushed stone.

Aggregate shall meet the following:

If the Collector Substation is not in Arkansas or Louisiana: Material designation - #610- Crushed limestone, primarily used in the Entergy system.

If the Collector Substation is in Arkansas: Material designation - Arkansas Department of Transportation Class 7 Base - Crushed granite or limestone, primarily used in Arkansas. Class 7 Base is a new designation that replaces the old designation (SB2). The materials in Class 7 and SB2 have the same gradation.

If the Collector Substation is in Louisiana: Material designation - Grade D Base (DGA) Dense Grade Aggregate m-crushed limestone.

Compaction: The crushed stone shall be compacted to a minimum density equal to 95% of the maximum density obtained by a Modified Proctor Test (ASTM D-1557). Do not grade ruts down; fill with additional aggregate and compact.

Sterilant: After sub grade preparation and prior to applying the crushed rock, a non-toxic vegetation eradicant (sterilant) shall be applied. Sterilant shall be applied from a minimum of five feet to a maximum of ten feet outside the fence.

Appendix 1: Collector Substation

5.8.1.8 Drive Access and Road Design

Substation ingress/egress points are to be compliant with all State and local Permitting requirements. A permanent all-weather twenty (20) feet wide roadway shall be provided for access and egress to the substation site directly from a public street or road. Such access road shall be adequate for construction and maintenance activities, including hauling heavy equipment such as the Collector Substation GSU. The access road shall have no less than 50 ft. centerline turn radii.

Roadways within the substation shall be provided, along the fence, if possible, for personnel and equipment movement. All roadways within the substation shall be at least twenty (20) feet wide with at least a fifty (50) feet centerline minimum turn radius. A reduced turn radius inside the substation is acceptable provided that an 18-wheeled low-bed vehicle loaded with equipment can easily negotiate all roads and turns within the substation fence enclosure. Road crossings over cable trenches, and culverts, shall be designed to withstand heavy traffic. Substation shall have only two points of entry in and out of the yard. The yard shall allow for vehicles to turn around or back out of the yard.

Note that new substations designated as Critical or Deemed Essential (**CODE**) (see Section 12 (PHYSICAL AND ELECTRONIC SECURITY)) shall include a vehicle access corridor around the exterior of the perimeter to allow drive-around access by security or law enforcement personnel.

5.8.2 Oil Containment

5.8.2.1 Federal Regulatory Requirements

Design and construction shall conform to 40 CFR, Parts 110 and 112.

Oil spill containment shall be provided for the main transformer. Oil spill containment shall be provided for other equipment when required by Governmental Authorities.

5.8.2.2 State and Local Regulatory Requirements

Oil containment shall comply with state and local requirements which are contained in 40 CFR Part 109. State and local governments have generally adopted the existing federal regulations prohibiting discharges of oil.

5.8.2.3 Containment System

Secondary oil containment type shall be an above grade containment pit.

Minimum containment volume is to be 100% of oil contained within protected equipment in addition to the volume of rainwater retained during a 24-hour 25-year recurrent interval storm event.

All designed water removal systems shall incorporate a method of monitoring discharged water quality. Monitors shall be connected to alarm systems.

In designing (sizing) a stone filled collection pit, the final oil level elevation shall be situated approximately 12 inches below the top elevation of the stone. This provides a fire extinguishing capability designed to quench flames if a piece of oil filled equipment catches fire. The use of 1.5 inch or larger stone (washed and uniformly sized) is recommended to permit quicker penetration to avoid a pool fire. Void Volume Ratio for stone filled devices shall be between 30 to 40 percent.

Pits using drainpipes shall assure that the drainpipe material shall be capable of withstanding the higher temperatures associated with an oil fire.

Appendix 1: Collector Substation

5.8.2.4 Oil Filled Equipment Separation

Oil-filled equipment shall be separated from other equipment and buildings to prevent potential fire hazards that may impede restoring or maintaining electric service. The following minimum separations from NFPA 850 Section 5.1.4 are suggested:

- Power transformers containing between 500 and 5,000 gallons of oil shall be located a minimum of 25 feet from any building unless the exposed walls consist of or are protected by a wall or barrier having a two-hour fire rating. The barrier shall extend horizontally and vertically such that any exposed part of the building is a minimum of 25 feet from the transformer. Transformers shall also be spaced an adequate distance from a fire-rated building wall to ensure that this 25-foot minimum is maintained to any other parts of the building that do not have a two-hour fire rating.
- For outdoor transformers with an oil capacity of greater than 5,000 gallons, maintain clear separation of 50 feet from other structures or provide a 2-hour fire rated barrier.
- A minimum distance of 8 feet shall exist between the transformer and any building or wall to ensure there is adequate space for normal operating and maintenance work. Cable trenches shall not be routed adjacent to oil immersed equipment.

Barriers that are required due to inadequate separation to equipment or buildings shall be constructed of non-combustible, heat-resistant, fire-rated material. The barrier height shall extend a minimum of 1 foot above the top of any oil filled equipment and any of their components. Barriers shall also extend horizontally a minimum of 2 feet beyond the line of sight of the subject building or equipment.

For transformers with less than 500 gallons of oil and where a firewall is not provided, the edge of the postulated oil spill (i.e., containment basin, if provided) should be separated by a minimum of 5 feet from the exposed structure to prevent direct flame impingement on the structure.

Any transformer for the Project using a listed “less flammable” insulating oil (e.g., Envirotemp FR3) shall be installed with and maintain a separation distance and barriers as provided above. If Seller seeks a modification of a separation distance or a barrier requirement for a transformer on the basis that the transformer will use a listed less flammable insulating oil, Seller shall perform and provide to Buyer a detailed hazard evaluation of such transformer with the proposed less flammable insulating oil. Buyer will consider such evaluation in its review of the modification request.

6 EQUIPMENT SUPPORT STRUCTURE LOADING

6.1 Load Cases

The load cases specified shall include the following environmental requirements:

Dead Load: The weight of equipment and support structures shall be included with appropriate increases for all equipment accessories and structure connections.

NESC District Loading (Rule 250B) - NESC District Loading shall be selected from *Table 25*, *Table 26*, *Table 27*, or *Table 28* based on Project location (Note that these districts may not match the district depicted in NESC for a given county). The ambient air temperature shall be taken as 0°F. Note that the load factors specified in NESC Table 253-1 shall only be used for this condition.

Extreme Wind: An Extreme Wind speed shall be selected from *Table 25*, *Table 26*, *Table 27*, or *Table 28* based on Project location (Note that the values in the tables may not match the maps depicted in NESC or ASCE 113 for a given county). Wind pressure shall be developed using ASCE 113. The Importance Factor

Appendix 1: Collector Substation

for Extreme Wind (**IFW**) loading shall be 1.0 corresponding to a 50 year mean recurrence interval per ASCE 113, Table 3-3. The ambient air temperature shall be taken as 60°F.

Concurrent Ice and Wind: A wind speed of 30 mph from any direction and a radial ice thickness shall be selected from *Table 25, Table 26, Table 27, or Table 28* based on project location applied on the equipment or structure. The Importance Factor for Concurrent Ice and Wind (**IFI**) loads shall be 1.0 corresponding to a 50 year mean recurrence interval per ASCE 113, Table 3-11. The ambient air temperature shall be taken as 15°F.

Short Circuit Loading: Determined in accordance with ASCE 113 and IEEE 605-2008 using electrical parameters determined from a site-specific analysis.

Seismic: Seismic design parameters (accelerations, site class, etc.) will be provided in the Geotechnical Report for each site. The seismic loads shall be calculated in accordance with ASCE MOP 113. Unless larger values are provided in the Geotechnical Report, the following minimum values shall be used for the mapped ground motion spectral response accelerations: $S_s = 0.140$ and $S_1 = 0.051$. The ambient air temperature shall be taken as 60°F.

Other: For equipment mounted on structures, the same design weather conditions shall apply. Loads associated with operation of the equipment shall be added to applicable load combinations.

Table 25: Load Districts by County - Arkansas and Missouri

State	County	Extreme Wind mph	NESC District			Concurrent Ice & Wind Case Ice Thickness inches
			Light	Medium	Heavy	
AR	Arkansas	100		M		1
AR	Ashley	100		M		1
AR	Baxter	100			H	1
AR	Benton	100			H	1
AR	Boone	100			H	1
AR	Bradley	100		M		1
AR	Calhoun	100		M		1
AR	Carroll	100			H	1
AR	Chicot	100		M		1
AR	Clark	100			H	1
AR	Clay	100			H	1
AR	Cleburne	100			H	1
AR	Cleveland	100		M		1
AR	Columbia	100		M		1
AR	Conway	100			H	1
AR	Craighead	100		M		1
AR	Crawford	100			H	1
AR	Crittenden	100		M		1
AR	Cross	100		M		1
AR	Dallas	100		M		1
AR	Desha	100		M		1
AR	Drew	100		M		1

Appendix 1: Collector Substation

State	County	Extreme Wind mph	NESC District			Concurrent Ice & Wind Case Ice Thickness inches
			Light	Medium	Heavy	
AR	Faulkner	100			H	1
AR	Franklin	100			H	1
AR	Fulton	100			H	1
AR	Garland	100			H	1
AR	Grant	100		M		1
AR	Greene	100			H	1
AR	Hempstead	100			H	1
AR	Hot Spring	100			H	1
AR	Howard	100			H	1
AR	Independence	100			H	1
AR	Izard	100			H	1
AR	Jackson	100			H	1
AR	Jefferson	100		M		1
AR	Johnson	100			H	1
AR	Lafayette	100		M		1
AR	Lawrence	100			H	1
AR	Lee	100		M		1
AR	Lincoln	100		M		1
AR	Little River	100			H	1
AR	Logan	100			H	1
AR	Lonoke	100		M		1
AR	Madison	100			H	1
AR	Marion	100			H	1
AR	Miller	100		M		1
AR	Mississippi	100		M		1
AR	Monroe	100		M		1
AR	Montgomery	100			H	1
AR	Nevada	100		M		1
AR	Newton	100			H	1
AR	Ouachita	100		M		1
AR	Perry	100			H	1
AR	Phillips	100		M		1
AR	Pike	100			H	1
AR	Poinsett	100		M		1
AR	Polk	100			H	1
AR	Pope	100			H	1
AR	Prairie	100		M		1
AR	Pulaski	100			H	1
AR	Randolph	100			H	1
AR	St. Francis	100		M		1
AR	Saline	100			H	1

Appendix 1: Collector Substation

State	County	Extreme Wind mph	NESC District			Concurrent Ice & Wind Case Ice Thickness inches
			Light	Medium	Heavy	
AR	Scott	100			H	1
AR	Searcy	100			H	1
AR	Sebastian	100			H	1
AR	Sevier	100			H	1
AR	Sharp	100			H	1
AR	Stone	100			H	1
AR	Union	100		M		1
AR	Van Buren	100			H	1
AR	Washington	100			H	1
AR	White	100			H	1
AR	Woodruff	100		M		1
AR	Yell	100			H	1
MO	Dunklin	100			H	1
MO	New Madrid	100			H	1
MO	Oregon	100			H	1
MO	Pemiscot	100			H	1
MO	Stoddard	100			H	1
MO	Taney	100			H	1

Table 26: Load Districts by Parish - Louisiana

State	Parish	Extreme Wind mph	NESC District			Concurrent Ice & Wind Case Ice Thickness inches
			Light	Medium	Heavy	
LA	Acadia	150	L			0.5
LA	Allen	125	L			0.5
LA	Ascension	150	L			0.5
LA	Assumption	150	L			0.5
LA	Avoyelles	110	L			0.5
LA	Beauregard	125	L			0.5
LA	Bienville	100		M		0.75
LA	Bossier	100		M		0.75
LA	Calcasieu	150	L			0.5
LA	Caldwell	100		M		0.75
LA	Cameron	150	L			0.5
LA	Catahoula	100	L			0.5
LA	Claiborne	100		M		0.75
LA	Concordia	100	L			0.5
LA	Desoto	100		M		0.75
LA	East Baton Rouge	150	L			0.5

Solar BOT Scope Book: Appendix 1 Collector Substation

Appendix 1: Collector Substation

State	Parish	Extreme Wind mph	NESC District			Concurrent Ice & Wind Case Ice Thickness inches
			Light	Medium	Heavy	
LA	East Carrol	100		M		0.75
LA	East Feliciana	125	L			0.5
LA	Evangeline	125	L			0.5
LA	Franklin	100		M		0.75
LA	Grant	100	L			0.75
LA	Iberia	150	L			0.5
LA	Iberville	150	L			0.5
LA	Jackson	100		M		0.75
LA	Jefferson	150	L			0.5
LA	Jefferson Davis	150	L			0.5
LA	Lafayette	150	L			0.5
LA	Lafourche	150	L			0.5
LA	Lasalle	100	L			0.75
LA	Lincoln	100		M		0.75
LA	Livingston	150	L			0.5
LA	Madison	100	L			0.75
LA	Morehouse	100		M		0.75
LA	Natchitoches	100		M		0.75
LA	Orleans	150	L			0.5
LA	Ouachita	100		M		0.75
LA	Plaquemines	150	L			0.5
LA	Point Coupee	125	L			0.5
LA	Rapides	100	L			0.5
LA	Red River	100		M		0.75
LA	Richland	100		M		0.75
LA	Sabine	100		M		0.75
LA	St. Bernard	150	L			0.5
LA	St. Charles	150	L			0.5
LA	St. Helena	125	L			0.5
LA	St. James	150	L			0.5
LA	St. John the Baptist	150	L			0.5
LA	St. Landry	125	L			0.5
LA	St. Martin, North	150	L			0.5
LA	St. Martin, South	150	L			0.5
LA	St. Mary	150	L			0.5

Appendix 1: Collector Substation

State	Parish	Extreme Wind mph	NESC District			Concurrent Ice & Wind Case Ice Thickness inches
			Light	Medium	Heavy	
LA	St. Tammany	150	L			0.5
LA	Tangipahoa	150	L			0.5
LA	Tensas	100	L			0.5
LA	Terrebonne	150	L			0.5
LA	Union	100		M		0.75
LA	Vermillion	150	L			0.5
LA	Vernon	100	L			0.5
LA	Washington	125	L			0.5
LA	Webster	100		M		0.75
LA	West Baton Rouge	150	L			0.5
LA	West Carrol	100		M		0.75
LA	West Feliciana	125	L			0.5
LA	Winn	100		M		0.75

Table 27: Load Districts by County - Mississippi

State	County	Extreme Wind mph	NESC District			Concurrent Ice & Wind Case Ice Thickness inches
			Light	Medium	Heavy	
MS	Adams	100	L			0.5
MS	Amite	110	L			0.5
MS	Attala	100	L			0.5
MS	Benton	100		M		1
MS	Bolivar	100		M		1
MS	Calhoun	100		M		1
MS	Carrol	100		M		1
MS	Chickasaw	100		M		1
MS	Choctaw	100		M		1
MS	Claiborne	100	L			0.5
MS	Clay	100		M		1
MS	Coahoma	100		M		1
MS	Copiah	100	L			0.5
MS	Covington	110	L			0.5
MS	Desoto	100		M		1
MS	Franklin	100	L			0.5
MS	Grenada	100		M		1
MS	Hinds	100	L			0.5
MS	Holmes	100		M		1

Appendix 1: Collector Substation

State	County	Extreme Wind mph	NESC District			Concurrent Ice & Wind Case Ice Thickness inches
			Light	Medium	Heavy	
MS	Humphreys	100		M		1
MS	Issaquena	100	L			1
MS	Jefferson	100	L			0.5
MS	Jefferson Davis	110	L			0.5
MS	Lafayette	100		M		1
MS	Lawrence	110	L			0.5
MS	Leake	100	L			0.5
MS	Leflore	100		M		1
MS	Lincoln	110	L			0.5
MS	Madison	100	L			0.5
MS	Marion	110	L			0.5
MS	Marshall	100		M		1
MS	Montgomery	100		M		1
MS	Neshoba	100	L			0.5
MS	Newton	100	L			0.5
MS	Panola	100		M		1
MS	Pike	110	L			0.5
MS	Ponotoc	100		M		1
MS	Quitman	100		M		1
MS	Rankin	100	L			0.5
MS	Scott	100	L			0.5
MS	Sharkey	100	L			0.75
MS	Simpson	100	L			0.5
MS	Smith	110	L			0.5
MS	Sunflower	100		M		1
MS	Tallahatchie	100		M		1
MS	Tate	100		M		1
MS	Tippah	100		M		1
MS	Tunica	100		M		1
MS	Union	100		M		1
MS	Walthall	110	L			0.5
MS	Warren	100	L			0.5
MS	Washington	100		M		1
MS	Webster	100		M		1
MS	Wilkinson	110	L			0.5
MS	Winston	100	L			0.5
MS	Yalobusha	100		M		1
MS	Yazoo	100	L			0.75

Appendix 1: Collector Substation

Table 28: Load Districts by County - Texas

State	County	Extreme Wind mph	NESC District			Concurrent Ice & Wind Case Ice Thickness inches
			Light	Medium	Heavy	
TX	Angelina	100		M		0.75
TX	Brazos	100		M		0.75
TX	Burleson	100		M		0.5
TX	Chambers	150	L			0.5
TX	Galveston	150	L			0.5
TX	Grimes	100		M		0.75
TX	Hardin	125	L			0.5
TX	Harris	125	L			0.5
TX	Houston	100		M		0.75
TX	Jasper	125		M		0.5
TX	Jefferson	150	L			0.5
TX	Leon	100		M		0.75
TX	Liberty	125	L			0.5
TX	Limestone	100		M		0.75
TX	Madison	100		M		0.75
TX	Montgomery	110		M		0.5
TX	Nacogdoches	100		M		0.75
TX	Newton	125		M		0.5
TX	Orange	150	L			0.5
TX	Polk	110		M		0.75
TX	Robertson	100		M		0.75
TX	Sabine	100		M		0.75
TX	San Augustine	100		M		0.75
TX	San Jacinto	100		M		0.75
TX	Trinity	100		M		0.75
TX	Tyler	110		M		0.75
TX	Walker	100		M		0.75
TX	Waller	110	L			0.5
TX	Washington	100	L			0.5

6.2 Load Combinations

All substation equipment support structures shall be designed using the load cases in Section 7 and using the provisions and load combinations of ASCE 113. Additionally, wire-supporting structures shall be designed per NESC construction "Grade B".

6.3 Structural Analysis

Computer aided analysis and design shall include secondary moments from non-linear effects (p-delta) for structure stresses. Analysis procedures shall be based on the applicable design document (AISC 360 for steel structural shapes, ASCE 48 for tubular steel structures, ACI 318 for concrete structures, ASCE 10 for lattice structures, the Aluminum Design Manual for aluminum structures, etc.).

6.4 Equipment Support Structure Design

Transmission line dead ends shall be located outside the substation, with a slack span inside the substation.

Structural supports for bus work, switches, and all other equipment shall be designed in compliance with ASCE MOP 113, and IEEE 605.

All substation structures, except dead-end structures, shall be designed and constructed using hot-rolled, structural steel square, rectangular, or tapered polygonal tubes. The dead-end structures shall be designed using tapered tubular polygonal shapes.

Per ASCE 113, polygonal tube structures shall be designed in accordance with ASCE 48. Per ASCE 113, structures designed with other structural shapes shall be designed in accordance with AISC 360.

6.5 Structure Deflection

For deflection load combinations, the deflection extreme wind shall not be determined by using a reduced return period per ASCE 113, Table 3-14. For the ice with wind load combination, the deflection ice thickness shall not be determined by reducing the ice thickness per ASCE 113, Table 3-15.

Structure deflections shall be checked for loading combinations with all load factors equal to 1.1.

The calculated deflections shall not exceed the values listed below.

- Wire-Supporting Structures and Shield Poles
 - Horizontal deflection of vertical members: 1/100 of height
 - Horizontal deflection of horizontal members: 1/200 of span
 - Vertical deflection of horizontal members: 1/200 of span
- All other Equipment Support Structures
 - Horizontal deflection of vertical members: 1/200 of height
 - Horizontal deflection of horizontal members: 1/300 of span
 - Vertical deflection of horizontal members: 1/300 of span

7 CONTROL HOUSE STRUCTURAL DESIGN

The control house shall be designed using the applicable building code as required by the authority having jurisdiction. If no oversight from the authority having jurisdiction is required, the International Building Code 2015 edition shall be used for design.

Design, fabrication, and erection of structural steel shall meet the requirements of the IBC, AISC Steel Construction Manual (AISC specification and AISC code of standard practice). Structural design shall comply with seismic design and detailing requirements of the IBC, ASCE 7, and AISC 341. It is preferred to have an Engineered/prefabricated and delivered to site precast concrete building. Steel, concrete, and Concrete Masonry Unit (**CMU**) buildings are all acceptable options.

7.1 Design Loads

Design loads shall be determined in accordance with IBC assuming a “Risk Category III”.

Roof dead load: Weight of built-up roof, roof joists, insulation, structural members, permanent equipment, cable tray fully loaded with cables, lighting, and any other items supported by the roof.

Floor dead load: Weight of AC/DC panels, control/relay panels, batteries, cable termination cabinets, and other electrical equipment supported on the floor.

Roof live load: 40 psf (minimum).

Snow load: Per the applicable building code. 10 psf ground snow load minimum.

Floor live load: 250 psf or a 1,300-pound load concentrated in any 2½ square foot area.

Wind load: Per the applicable building code. 120 mph (minimum).

Seismic: Per the applicable building code.

7.2 Fall Protection

Buildings shall be constructed to include permanent anchorage points to accommodate personal fall protection systems capable of supporting 5,000 pounds per worker (OSHA defined impact load). For elevated houses, permanent anchorage points shall additionally be included on the walls of the control house adjacent to each exterior door to accommodate personal fall protection systems for use when working on the platform. All anchorage points shall be shown on roof drawings and marked on control house if not easily visible.

7.3 Roof

The roof shall have a minimum slope of ¼ inch in 12 inches; designed and constructed as specified by the IBC. The control house shall have a freestanding roof with no interior vertical supports to support the roof ridge beam.

7.4 Cable Tray

The cable tray and other suspended items shall be adequately supported to resist applied loads including, but not limited to, dead loads, cable pulling loads, and seismic loads.

The cable tray shall be capable of carrying a uniformly distributed load of 75 pounds/ft in addition to the weight of the cable tray with a safety factor of 2.0 when supported as a simple span.

8 FOUNDATIONS

Foundation design will incorporate the soil capacity determined from the Geotechnical Report. Foundation design shall conform to ACI 318 and county and state codes.

Drilled pier/shaft and slab-type foundations shall be used. Alternative foundation systems may be considered if agreed upon between Buyer and Seller.

Ground supported pieces of equipment, such as circuit breakers and transformers, shall be supported by cast-in-place reinforced concrete slabs unless otherwise indicated by the Geotechnical Report.

Transformers shall be positively anchored to supporting foundations.

Solar BOT Scope Book: Appendix 1 Collector Substation

Appendix 1: Collector Substation

Foundations for the equipment support structures (bus supports, switches, etc.) and transmission line dead end structures shall be cast-in-place reinforced concrete drilled piers or spread footings, whichever is appropriate based on the subsurface soil information, unless otherwise indicated by the Geotechnical Report. Anchor bolts for all structures shall be of sufficient length to allow for the use of leveling nuts. The use of grout between the structure base plate and the top of the structure foundation is not required.

The control house foundation shall be piers or concrete slab. A cable routing and pulling area will be designed to facilitate connection with the conduit or pre-cast concrete cable trench entry from the substation and shall be located beneath the termination cabinet(s).

Foundation designs shall be in accordance with the following general minimum criteria:

- a) Concrete strength $f_c = 4,500$ psi at 28 days
- b) Grout auger cast piling $f_c = 5,000$ psi at 28 days
- c) Reinforcing steel (ASTM A615 Gr 60) $f_y = 60,000$ psi
- d) Foundation loads

Structures From structure design calculations

Equipment From original equipment manufacturer shop drawings or product literature

Importance Factor

Structures/Foundations - 1.0 for non-essential facilities

Safety factors (foundation reactions shall be service loads)

Shallow Foundations – Bearing Capacity 3.0

Shallow Foundations – Stability (Overturning, Sliding, and Uplift) 1.5

Drilled Piers Not less than 1.5, preferably 2.0

In general, foundations shall extend below the Finished Grade as required by local or state code and the recommendations in the Geotechnical Report. The Geotechnical Report shall clearly state the safety factors needed for each site.

8.1 Foundation Deflection and Rotation

Deflection and rotation of drilled pier foundations shall be limited to 0.5 inch of deflection (vertical and horizontal) and 0.5 degrees of rotation due to unfactored (service) loads.

8.2 Materials

Structural steel shapes, plates, and appurtenances for general use shall conform to ASTM A992 or ASTM A572 grade 50 (wide-flange shape and ASTM A36 (other shapes)). Steel pipes shall conform to ASTM A53 grade B. Structural tubing shall conform to ASTM A500 grade B. Primary connection bolts shall conform to ASTM A325, type 1 or ASTM A490, type 1 with ASTM A194 grade 2H heavy hex nuts and steel washers conforming to ASTM F436 or Compressible-Washer-Type Direct Tension Indicators conforming to ASTM F959. Connection plates shall be ASTM A36 or ASTM A572 grade 50 steel. Steel components for metal wall panels, roof decking, and cold-formed girts and purlins shall conform to the North American specification for design of cold-formed steel structural members (AISI-S100).

Welded connections shall be made with welding electrodes with a minimum tensile strength of 70 ksi. Bolted connections shall be made with minimum 5/8-inch diameter ASTM F3125 Grade A325 high strength bolts, and shall typically be fully pre-tensioned Type N connections with threads included in the shear plane, unless noted otherwise. Connections subject to significant stress reversals or as otherwise required by the AISC shall be designed as slip-critical connections.

Appendix 1: Collector Substation

Welding procedures and qualifications for welders shall be in accordance with AWS D1.1 structural steel welding code and AWS D1.3 sheet steel welding code. Welding electrodes shall be as specified by AWS.

Preparation of metal surfaces for coating systems shall follow the specifications and standard practices of the SSPC, NACE, and the specific instructions of the coatings manufacturer. All structural steel for exterior use shall be hot dip galvanized steel per ASTM A123 and ASTM 153, unless noted otherwise. All structural bolts shall be galvanized, unless noted otherwise. Steel assemblies shall be safeguarded against embrittlement and warping during hot dip galvanizing per ASTM A143 and ASTM A384. Repair of damaged and uncoated areas of hot-dip galvanized steel shall be per ASTM A780.

8.3 Record Documents

Seller shall provide Buyer with structure and foundation detail drawings and supporting calculations. The drawings shall note all loading criteria used in the design. Foundation details shall note the structure base reactions used in the design. Drawings shall contain appropriate information (e.g. dimensions, materials, weld data, etc.) to allow reanalysis of the structure under future loading conditions.

9 FENCE & SIGNAGE

All substations shall have a fence at least eight feet high (seven feet of fabric and one foot of barbed wire). Fences shall consist of chain link fabric, with 3 strands of barbed wire on 45-degree extension arms, with no ground gaps greater than two (2) inches and secure. All steel, including pipe, roll-formed sections, and fittings to be first quality, full weight, "hot-dipped galvanized" as per ASTM-F1234 or ASTM-F1083. The fence fabric shall be aluminum coated steel according to ASTM-A491. Safe step and touch potential of the perimeter fence shall be verified by an IEEE 80 compliant grounding study.

9.1 Gates

Drive gates shall be equipped with heavy duty drop bars, drop bar keepers, stops, and flip-over latches (as required) to be locked by standard Entergy lock(s). Hinges shall be heavy duty and shall allow gates to swing either in, or out, or in and out of all gate leaves.

Gates shall be operational from both sides of the gate. Gates shall clear Finished Grade by not more than 3". Gate locking mechanism shall be installed with 3/8" diameter case hardened bolts. The nuts on the bolts shall be incapable of being removed, either by using lock nuts, splitting the end of the bolts or by welding the nuts on the bolts.

The Collector Substation shall have one motor operated sliding gate and an additional non-motor operated sliding gate or one main gate.

Features of the motor operated sliding gate(s) shall include the following:

- Sliding gate shall be four feet (4) greater than width of entrance road
- An electric gate operator (Lift Master Elite or newer equivalent or better), including associated items
- A hard-wired continuous power connection (if available)
- A hard-wired keypad gate opener (not wireless) located at the gated entrance (exterior side of the Project Site fence)
- A pedestal mount, conduits, and wiring at the gated entrance
- A hard-wired push-button gate opener located at the gated exit (interior side of the Project Site fence); exit ground loop not required
- A pedestal mount, conduits, and wiring for the gated exit
- Sliding gate shall be grounded

Appendix 1: Collector Substation

- Additional security requirements are found in Section 12 (PHYSICAL AND ELECTRONIC SECURITY).

9.2 Signage

A “Danger – High Voltage – Keep Away” sign shall be placed on the exterior of the fence at a maximum spacing of 50 ft. The sign shall be visible and readable from any angle the substation fence can be approached.

10 SUBSTATION PHYSICAL DESIGN CRITERIA

10.1 Substation Bus System

10.1.1 Bus Systems

The bus system consists of the bus conductor, bus insulators and supporting structures, and jumper conductors to equipment and lines. The bus system shall be designed to meet the voltage and continuous current rating requirement, as well as the mechanical requirements for bus design strength and deflection for all cases and conditions.

Rigid bus structures shall be designed per IEEE Std. 605, IEEE Std. 1427 and in compliance with the NESC. The bus work must be designed to withstand all required weather conditions appropriate for the location of the station and withstand all forces due to maximum fault current.

Bus dampening shall be accounted for during detailed design and be between 10% and 33% of the bus conductor weight.

10.1.2 Bus Configuration

The layout of the bus design shall minimize the crossing of bus sections and equipment by lines and other station buses. This is to reduce or eliminate possible common mode failures and to permit service work to be performed without having to take additional busses or equipment out of service.

The design shall be of the low-profile type using rigid bus in a horizontal (flat) configuration on vertically mounted station post insulators.

Hookstick-operated disconnect switches shall be provided on both sides of all feeder breakers.

If so directed, the bus configurations of the substation facilities shall take into account future expansion. The physical layout shall be made so that expansion can be accomplished with the least amount of outage time when required.

10.1.3 Bus Fittings

Bus fittings used for rigid bus connections shall consist of welded connectors.

Fittings used for stranded conductor shall consist of either bolted, compression or welded types. For incoming lines to the substation Dead End (*DE*) structure, the use of quadrant clamps is acceptable. In applications where connection to a line surge arrester is required, the use of bolted connectors is preferred to compression connectors due to the potential chance of incorrect installation and bird caging effect on the incoming conductor. If using compression fittings for the incoming transmission line span, the compression tee and dead-end fittings shall have NEMA 4-hole or 6-hole terminal pads for connection of conductor jumpers.

Appendix 1: Collector Substation

Fittings used for conductor jumpers shall be of the bolted, compression, or welded type to a bolted pad. Jumpers shall be designed so that they can be unbolted and removed from equipment for maintenance, repair, or replacement.

10.2 Station Layout

The collection system shall be identified and marked. This includes all the phases on pad mount transformers, as well as any time the system transitions from underground to over ground or vice versa. An acceptable method of identification is stickers.

10.3 Phase Orientation

The phasing orientation of the substation shall be A-B-C when facing the low side transformer bushing left to right. If the phasing is different for the interconnecting utility, notation shall be added to the drawings detailing the phase rotation. Additionally, all equipment and busses shall be labeled.

10.4 Grounding System

High voltage structures will be connected to a ground grid. All metallic equipment, structures, and fencing will be bonded to the ground grid utilizing properly rated conductors and ground rods, as required for personnel safety.

10.5 Grounding Design Criteria

The grounding system shall be designed using field resistivity values obtained from geotechnical studies. Substation ground grid design shall be based upon IEEE Std. 80 and NESC. Parameters to be used in the design, such as fault current magnitude and duration, will come from various studies, such as the Facility Study and other interconnection studies, and relay and protection system evaluation. Seller shall use fault current split factor calculations that consider OHGW, OPGW and feeder neutral grounding, in order to lower the effective ground fault current. The substation ground grid shall be connected to the overheard transmission line shield wires unless specifically isolated due to other engineering considerations. Clearing time for grounding analysis shall not be shorter than the total time for backup relay operation plus breaker time.

The ground grid analysis shall seek to optimize the cost and complexity of the installation. Multiple design iterations shall be developed, considering varying depths of substation rock, grounding conductor size, grid spacing, ground rod depth, etc., until an optimized, lowest-cost design is achieved.

Grounding analysis shall address seasonal conditions as appropriate, such as seasonally dry soil conditions or frozen earth conditions. The ground grid shall be designed to account for the most-restrictive weather conditions.

The grounding system shall be modeled using grounding analysis software. SES CDEGS, WinIGS, or equivalent.

10.6 Grounding System Components

10.6.1 Soil Structure:

Grounding analysis software shall be used to determine the number of soil layers present based on field test results input. The soil model results are considered usable if the resultant soil model accurately reflects the measured data.

Appendix 1: Collector Substation

The original soil model shall be adjusted to minimize the rms error.

10.6.2 Ground Grid:

Ground grid conductors shall be optimized for cost, considering the fault current magnitude and other parameters. Copper clad steel should be considered where appropriate, but soil corrosivity shall be considered when evaluating the use of copper clad steel.

The ground grid shall be installed at a minimum depth of eighteen (18) inches below Finished Grade (i.e. grade not including any rock cover).

Ground grid shall extend to cover the swing access for all man and vehicle gate access points as well as any pad mount transformers and other medium or low voltage station service equipment located close to the substation fence. Recommended to go three (3) feet beyond the fence or overall equipment/gate offset.

10.6.3 Grounding Rods

The standard ground rod shall be 10-feet-long and made of 5/8-inch diameter copper-clad steel rod. It is acceptable for longer lengths to be made by joining multiple rods together with ground rod couplers. Longer ground rods shall be considered before more costly methods (such as ground wells) are implemented.

Ground rods shall be installed at applicable ground grid locations or at locations dictated by design. Applicable locations include substation perimeter, dead-end structures, lightning masts, surge arrestors, control house corners, etc.

10.6.4 Grounding Connections

All underground ground grid cable-to-cable and cable-to-ground rod connections shall be made with exothermic connections (Cadweld or equivalent). All above ground grounding connections shall be made with mechanical, bolted, or compression connections.

10.6.5 Above Grade Grounding Provisions

The perimeter fence shall be connected to the substation ground grid at each gate post, every corner and along the fence at intervals dictated by design. Grounding of the fence shall also include grounding provisions for the fence fabric and barbed wire.

All four corners of the control house shall be connected to the substation ground grid.

Two grounding conductors shall be installed the entire length of all pre-cast concrete cable trench greater than 36 inches wide. For pre-cast concrete cable trench less than 36 inches wide a single grounding conductor shall be installed. These conductors shall provide a convenient access to the substation ground and shall provide some shielding of control cables from electrostatic interference. They shall be connected to the ground grid at all main grid crossings and sized to match the ground grid conductor size.

Personnel safety mats (galvanized steel grating) shall be installed on top of the crushed rock surfacing at each disconnect switch operator, manual or motor-operated gang switches, and each personnel entrance to the control enclosure if metal steps are used. Safety mats shall be bonded to the station ground system in accordance with IEEE 80.

Equipment and structure grounds, or "stingers," consisting of bare conductors shall connect each piece of the substation equipment and steel structure to the ground grid. The minimum conductor size shall be calculated but never be smaller than the ground grid conductor size. There will be two (2) ground connections to each structure and piece of equipment.

Ground studs shall be installed on every breaker bushing pad. Provisions for portable safety ground installations, either bus \leq 3-inch diameter, ground studs, or grounding stirrups, shall be included at both

Appendix 1: Collector Substation

sides of all disconnect switches. Grounding studs shall be placed such that there is no interference from other equipment (for example, disconnect switch blades).

10.6.6 Crushed Rock

The site will be covered with a layer of crushed rock as defined in Section 5.8.1.7 (Site Surfacing). The crushed rock shall be installed throughout the entire substation area and extend 5 feet beyond the fence and swing radius of the gates.

Resistivity tests shall be performed on potential material sources early in the design phase, and those results shall be integrated into the overall grounding system design. The IFC grounding design shall use material with a known, tested resistivity; no assumptions should be made as to the availability of rock of a certain resistivity.

10.6.7 Grounding Drawings

The design input from the grounding calculation shall be recorded on the grounding drawing in a concise table. The table shall include all pertinent information, including, but not limited to, final design grid resistivity, depth of crushed rock, rock resistivity, length of ground rods, size of grounding conductor, soil parameters, design fault current, and fault duration. Additionally, it shall be included a field on the grounding drawing for the contractor to record the final fall of potential test results.

10.7 Conduit System

All conduit and raceway systems shall comply with NEC and NESC requirements. The conduit and raceway system design shall accommodate power and control cables, communication circuits, underground feeders, and optical fiber cables.

10.7.1 Conduits

Low voltage cables used for protection and control, or station power shall be placed in conduit wherever they connect to oil immersed equipment to reduce the risk of burning oil flowing in raceways and causing severe damage to cables. All conduit systems including wiring size shall be detailed on drawings.

Conduit shall be schedule 40 or greater PVC for below grade or above grade applications. Flexible conduit may be used for transitions where necessary. Galvanized steel conduits shall not be used in below-grade applications. Conduits shall be sized in accordance with the NEC (NFPA-70). Where applicable, 2 inch and 4-inch conduits shall be used.

Designs shall incorporate one spare conduit per transformer (main GSU) and circuit breakers 138 kV and above.

All below-grade conduits shall be buried to a minimum depth of twenty-four (24) inches below the Finished Grade (approximately six inches below the ground grid). The conduit system for the 34.5 kV collector cables shall extend 10 feet beyond the fence and shall be concrete-encased. Additional coordination shall be made with the collector system designer.

10.7.2 Cable Trench

For substations and collector facilities that have more than one main GSU transformer, precast concrete trench systems shall be installed. It shall be identified early in detailed design if the current Project will ever be expanded with a second or third phase. If additional phases are planned, the initial layout shall be designed such that adding new cable trench can be implemented while minimizing the impact to existing facilities.

Appendix 1: Collector Substation

Precast concrete trench with a pedestrian strength rating shall be specified for the substation yard raceway system. HS-20 rated road crossing cable trench shall be used for all vehicle crossing locations. Each vehicle crossing location will be marked with high visibility bollards extending at minimum three (3) feet above the ground and visible during winter snow conditions. Applications for the use of a barrier internal to the cable trench or multiple trench systems may be utilized where required.

Conduits shall be provided between the concrete trench system and yard mounted equipment

On two transformer stations or an integrated ring bus switchyard, a partial cable trench system is normally required, and provisions shall be provided in detailed design.

10.7.3 Pullboxes

Cables entering the control house from the substation yard shall be routed through a pre-cast cable vault and pulling area into the control house termination cabinet.

10.7.4 Cable Entry and Trays

All conduit and cable entry openings into the control house shall be tightly sealed as a barrier to animals to keep out moisture and to minimize heat loss. Cables entering the control house shall be terminated at the appropriate termination cabinet or AC or DC panel board.

Inside the control house overhead cable tray suspended from the ceiling shall be used to route cables between the termination cabinet, control and relay panels, and other equipment.

10.8 Lightning System

The substation direct lightning stroke shielding design shall be performed in accordance with IEEE Std 998-2012 "IEEE Guide for Direct Lightning Stroke Shielding of Substations" using the "electro-geometrical model" or the "rolling sphere technique". For small stations it is acceptable to use the fixed angle method as a means for determining proper shield protection locations.

After the substation layout is completed, the direct stroke shielding shall be analyzed to verify that the equipment within the substation fence is adequately protected. The transmission line static wires shall be connected to the substation ground grid.

The following criteria shall be used for the lightning shielding design:

- Station BIL, *Table 2*.
- Lightning stroke density shall be that for the Project area as reported by the Fault Analysis and Lightning Location System
- A design failure rate of less than one shielding failure in one hundred (100) years.

The shielding design shall utilize a combination of shield wires, shielding masts and/or mast poles. Shield wires over substation buses shall be arranged such that there is no more than a single bus between shield wire supporting structures.

All static wires from the transmission lines shall terminate into the station lightning shielding system.

10.8.1 Lighting System

The primary purpose of substation lighting is to provide sufficient illumination for personnel safety and emergency equipment maintenance. The substation shall be provided sufficient illumination during the night for safe passage of the maintenance crew who might be performing equipment inspection or maintenance. Outdoor lighting is often also intended to deter vandalism; however excessive illumination may attract vandals or result in complaints from the surrounding community. Lighting is also used in certain

Appendix 1: Collector Substation

areas to deter birds from roosting and/or nesting. Yellow color lighting such as sodium vapor does not attract as many bugs, flying bats and birds that in turn attract snakes and climbing animals.

Proper placement of lighting is important. Placement of lighting shall consider the collection of insects on adjacent energized equipment. Large quantities of these bugs can attract animals and increase risk of animal outage.

At least minimum illumination levels recommended by National Electrical Safety Code C2 shall be provided in generating stations and substations. Illumination levels relevant to substations are as follows:

- a) Emergency exit path: 1 foot-candle (11 lux)
- b) Control house (occupied): 15 foot-candles (165 lux)
- c) Control house (unoccupied): 5 foot-candles (55 lux)
- d) Front of switchboards and panels: 15 to 25 foot-candles (165 to 275 lux)
- e) Fence: 0.2 foot-candles (2.2 lux)
- f) Substation general horizontal: 2 foot-candles (22 lux)
- g) Substation vertical (on disconnects etc.) 2 foot-candles (22 lux)
- h) Roadway: 0.5 foot-candles (5.5 lux)
- i) Open yard: 0.2 foot-candles (2.2 lux)

The need for detailed lighting design for each substation shall be individually evaluated depending upon the substation's location, site area, type of buswork structures, and the equipment installed in it. LED light fixtures shall be installed for all new installations. The following is required as a minimum for typical substation lighting:

- a) The entrance gate into the substation shall be provided with a motion-activated photocell-controlled light.
- b) The substation control house entry doors shall be provided with motion-activated photocell-controlled lights.
- c) The substation shall have switched, photocell-controlled lights, preferably with a timer, for safe passage. The control switch shall be in the control house.
- d) A sufficient number of Ground Fault Circuit Interrupter (**GFCI**) outlets shall be provided in the substation near the equipment e.g. circuit breakers and power transformers for portable light hookup for nighttime repairs and maintenance. GFCI outlets provided in the equipment control cabinets shall be used for this function.

10.9 Substation Security/Safety

Substation Security shall not apply for substations below 161 kV. However, depending on the Project interconnection area, additional requirements may exist due to other evolving cyber security concerns. Check with Buyer - Transmission Planning for site specific concerns.

10.10 Animal Deterrents

Means for animal deterrent and mitigation shall be provided in all medium voltage substations, and the MV section of all high voltage substations.

IEEE Std 1264 provides guidance on methods and designs to mitigate animal intrusion and resulting interruptions and equipment damage.

Animal mitigation shall be achieved by applying substation insulators that have a large enough flashover distance to prevent bridging by animals, such as snakes and squirrels, by increasing phase spacing and by providing guards and covers for insulators or adding barriers between phases to prevent phase to phase bridging by birds. Guards and covers shall be installed on all MV equipment bushings listed below regardless of the spacing.

Solar BOT Scope Book: Appendix 1 Collector Substation

Appendix 1: Collector Substation

Insulating covers shall be installed on all medium voltage equipment bushings as follows:

- a) Power transformers
- b) Station service transformers
- c) Voltage regulators
- d) Circuit breakers and reclosers
- e) Surge arresters
- f) Capacitors
- g) Instrument current and voltage transformers
- h) UG cable terminations
- i) MV switches and jumpers

Insulators in substations where higher BIL bus and disconnect insulators cannot be applied shall be protected by suitable guards and covers.

MV substation equipment including 34.5 kV equipment shall be provided with guards and covers and each phase shall be covered for a distance of three (3) feet, unless otherwise specified during the constructability review. The center phase shall be fully covered. Depending upon location and known animal intrusion problems, additional mitigation may be required.

10.11 Substation Protection & Control Design Criteria

10.11.1 Protection and Control Requirements

The protective relaying shall:

- a) Preserve the integrity of the ELL Transmission System by being dependable and secure to the appropriate level of required reliability as specified by Entergy Transmission Planning.
- b) Properly coordinate and function with other Entergy relay schemes, and neighboring utilities.
- c) All Collector Substation protection relays, both primary and backup, shall be SEL as stated in ATTACHMENT 1: APPROVED MANUFACTURERS LIST FOR COLLECTOR SUBSTATION).

10.11.2 Backup and Transfer Trip

Breaker failure backup and/or transfer trip circuits to interface with other stations shall always be provided.

10.11.3 Transmission Line Protection

Transmission line protective relay equipment at the Collector Substation shall be provided to meet the requirements of Buyer - Transmission (as the host utility).

HV transmission lines shall have a dual primary line protection scheme comprising of dual primary communication assisted tripping relaying scheme. Each primary protection scheme shall utilize separate instrument current transformers, or separate current transformer cores of a free-standing current transformer, separate CVT or PT secondary windings, and separated DC and AC supplies from a common distribution panel. Breaker control is typically on the same line panel.

10.11.4 Bus Protection

HV and MV bus shall use single low or high impedance protection scheme. Low impedance is preferred. If using high impedance protection, all of the current transformers in the circuit shall have the same ratio and must be tapped at the full ratio.

Appendix 1: Collector Substation

10.11.5 Transformer Protection

Each power transformer shall be protected by a minimum of one and, preferably, two differential relaying schemes. The transformer differential relay shall be connected to the transformer high side bushing current transformers. Low-side circuit breaker or transformer bushing current transformers shall be positioned to provide a sufficient area of overlap between adjacent protective zones. Protection zones shall be created to prevent through-bus interruption for transformer differential operation.

Back up time overcurrent transformer overload relaying shall be provided.

GSU transformers shall be purchased and supplied with the following integral monitoring devices:

- a) Oil level gauge on tank wall or conservator.
- b) Pressure relief device(s). The pressure relief device is used for alarms. Transformer tanks containing more than 10,000 gallons of oil shall be provided with two pressure relief devices mounted on diagonally opposite corners of the transformer tank. The device(s) shall be located remote from the control cabinet(s). The pressure relief value shall be stamped on the device(s).
- c) Sudden pressure rise relays. Transformers are specified to have two sudden pressure relays used to trip the transformer when both relays have operated. A sudden pressure or Bucholtz relay (Device 63) shall be provided, including seal-in contacts in an enclosure with a threaded conduit hub and "loss of DC indication".
- d) Gas accumulation detecting relay (conservator tank units). Contacts of the gas accumulation detecting relay are used for alarm.
- e) Temperature monitoring system to indicate top oil and winding temperatures.

Seller shall design the system so as not to trip and isolate transformers due to the operation of pressure relief devices, high oil temperature, and high winding temperatures. Main power transformers shall be tripped and isolated when the oil level in the transformer tank falls below the critical level to prevent internal flashovers. GSUs or main power transformers shall have critical oil level as an alarming feature only and no tripping.

10.11.6 Capacitor Bank Protection

See IEEE Std C37.99 – IEEE Guide for the Protection of Shunt Capacitor Banks for detailed guidance on the capacitor bank protection schemes. Seller shall employ the Unbalance Detection scheme for the protection of the capacitor bank. The aim of this scheme is to trip the capacitor bank if there are unbalances in the phases that result in voltages 110% or more across the individual capacitor unit.

10.11.7 Shunt Reactor Protection

See IEEE Std C37.109 for guidance on the protection of shunt reactors. Studies shall be conducted to determine if snubbers are required for reactor switching. Surge arresters are recommended for all reactor applications.

10.11.8 HV Breaker Control

Gas insulated circuit breakers are specified to be equipped with two or more stages of gas pressure/density monitoring contacts.

- a) Contact of the first stage closes on falling pressure at approximately 10% loss of pressure, and
- b) Contact of the second stage closes on falling pressure at a further 10% reduction of gas pressure.

Appendix 1: Collector Substation

Most manufacturers comply with these requirements except that the first stage and second stage contacts may not necessarily close at 10% loss of pressure for all makes and models of the circuit breakers.

A circuit breaker retains its full electrical and mechanical rating at this second stage pressure/density of gas in the circuit breaker. However, the circuit breaker manufacturer will not guarantee any rating below this pressure and, accordingly, the circuit breaker operation shall be disabled below this pressure.

The manufacturers of circuit breakers generally do not offer any specific recommendations for the circuit breaker's continued operation when the second stage contacts of the gas density monitor close. It will be the responsibility of Buyer to determine whether a circuit breaker should be tripped (if it was already closed) or block any close/open operation under these conditions.

Since the system security, substation importance, and the circuit breaker applications within the substation vary throughout the system, a common system wide approach on whether to trip or block operation of all circuit breakers cannot be specified.

The following is a recommended plan of action, keeping in mind that the circuit breaker retains full rated values at the second alarm stage, and it is capable of withstanding normal system voltage with the gas in the interrupters at atmospheric pressure. Under ideal conditions and with a standard 0.5% gas leakage rate it would take more than five years for any alarm stage to be generated for most breakers. A second stage alarm usually signifies a rapid loss of gas.

The circuit breaker control scheme shall address the loss of gas alarms as follows:

1. First stage alarm: Effort shall be made to investigate the cause within eight hours (or the next day at the latest).
2. Second stage alarm received within one day of receiving the first stage alarm: In locations where the system continuity can be maintained (ring bus, or breaker and half bus substations) the circuit breaker shall be tripped immediately. If the system continuity cannot be maintained, then the circuit breaker operation shall be blocked. In substations with a single bus the circuit breaker operation shall be blocked. It may be necessary to include timers in the relay scheme to achieve this requirement. This should be evaluated during detail design.
3. Second stage alarm received more than one day after receiving the first stage alarm: Block circuit breaker operation.

All HV breaker control relays shall include Lockout Relays (**LORs**).

10.11.9 HV Motor Operated Switch Control

When HV Motor Operated Switches (**MOSs**) are used, if a control building is used, it is preferred that the MOS controls be located on the applicable line protection, transformer protection, or breaker control panel.

If no control house is required, the panel design must be modified to fit in a suitable NEMA type 4X stainless steel outdoor enclosure.

10.11.10 MV Collection Feeder Protection

Primary feeder protection will be provided by an SEL-351S or similar relay at each feeder breaker. Instantaneous and time overcurrent phase and residual ground are typical elements to protect the feeder section. Additional voltage and frequency elements will be enabled to ensure compliance with NERC reliability requirements (e.g., PRC-019, -024, and -026, if applicable).

Breaker failure initiate will be enabled to ensure coordination with MV bus and transformer differential if a breaker fail occurs.

10.12 Relay Calculations and Setting Requirements

For relay settings, refer to TE-SD-AD-007 (Relay Settings Procedure) and PM1804 (Transmission Line Relay Setting Criteria, Design and Operation Guide) for guidance. Relay settings shall meet the requirements of NERC reliability standards PRC-019, -023, -024, -025, and -026, as applicable.

Typical Relay Engineering Calculations:

- Battery Bank Sizing & Design: IEEE-485 & NEC – Article 480.
- Battery Charger Sizing: EPRI Stationary Battery Guide (Design, Application, and Maintenance)
- DC Load Center Sizing: Requires building DC loading table (Watts / Amps) for yard and enclosure (panel) equipment – Nameplate information and/or equipment manuals required.
- AC Load Center Sizing: Requires building AC loading table (Watts / Amps) for yard and enclosure (panel) equipment – Nameplate information and/or equipment manuals required.
- Station service sizing
- Voltage Drop Calculations (use as guide only): NEC: 215.2(A)(4)
- Conductor Ampacity Calculations (use as guide only): NEC Table(s) 310.15 (Engineer to select correct table for use)
- Grounding Methods for Electrical Supply: NESC Sec. 9
- Size of Equipment Grounding Conductors (use as a guide only): NEC Sec. 250.122 and Table 250.122.
- Cable in Conduit Fill Calculations: NEC Tables 310.15(B)(2)(a) & 310.15(B)(3)(a), Chapter 9, Table 1, Table 4
- Cable Tray Fill Calculations: NEC 392.22, Table 392.22(A).

11 CONTROL HOUSE

The control house shall be designed to comply with the latest version of the IBC, and with local building code requirements. See Section 5.7 (Control House). It is preferred to have an engineered/prefabricated and delivered to site precast concrete building. Steel, concrete and CMU buildings are all acceptable options.

The control enclosure shall contain Vendor-provided station services such as primary and backup AC supply disconnects, an automatic AC transfer switch, AC load centers, DC power system and storage battery, and air conditioning units.

The Vendor shall be capable of meeting any state-specific certification and/or inspection requirements.

The control enclosure shall be suitable for placement upon both concrete slab and concrete pier foundation types. An indication of design loads for both foundation types shall be supplied with the Vendor's engineering documentation.

All Vendor-supplied equipment within the control enclosure shall use equipment enclosures conformant to at least the NEMA 1 specification. External equipment shall be appropriately rated and weatherproofed for exterior installation.

The control enclosure shall contain space for equipment including:

- a) Control enclosure shall be sized to account for all necessary equipment in the station ultimate configuration. No more than sixteen 27-inch, free-standing relaying and control panels in a single row. All cable access to the panels will be from a cable tray system above the panels.
- b) One wall-mounted termination cabinet having dimensions of up to 72 inches x 90 inches x 24 inches.

Appendix 1: Collector Substation

- c) Communications equipment including fiber-optic, telecommunications, and related interfacing gear.
- d) Separated control room is required for all projects.
- e) The control enclosure shall have a minimum internal ceiling height of 10 feet to allow for adequate equipment clearance below the cable tray.

Wall space shall be left open to the greatest extent practical. Conduits and raceways provided by Vendor for building services and included equipment shall be placed at or near the ceiling with vertical service drops. Horizontal raceways and conduits between adjacent equipment such as load centers are acceptable.

The control enclosure shall include one eye-wash system with two saline cartridges when there isn't water brought to the site.

11.1 DC System

One (1) VLA 125 VDC battery system shall be provided along with (2) 130 VDC battery chargers. The batteries and chargers shall be sized in accordance with IEEE 485 and considering substation ultimate configuration (if any). The calculation shall consider worst case tripping scenario along with dual trip coil operation. A single charger shall be able to fully charge a completed battery within eight to twelve hours while supplying normal loads.

Dual DC load centers shall be provided within the control house. DC load centers shall be designed with enough circuit positions for the substation's ultimate configuration. Each DC load center shall be rated 125 VDC and shall have a main circuit breaker. The DC load centers breaker position and total circuits requirement shall be dictated by final approved DC Calculation considering ultimate substation configuration. DC load centers shall be dead-front design, installed on the control enclosure wall, and provided with conduit access to the cable tray.

Battery chargers shall not have an alarm "on/off" switch. Each battery charger installed in the station shall alarm on zero current output. Dual charger setups shall be wired for parallel operation. When properly set up each charger shall share half of the battery bank charging current.

Battery banks shall be located in a separate room of the control house. There shall be enough space so field personnel can reach each cell and battery terminals for testing and maintenance. A minimum of 24 inches height separation between battery racks is needed to accomplish this.

Battery DC grounds shall be monitored via indicating lights on the front panel of the battery charger and indication of a DC ground shall be an input to the station RTU. Battery voltage shall be an input to the station RTU.

11.2 AC System

The substation will be equipped with normal and backup AC station service sources supplying 120/240 VAC, 3 wire, single phase power. Station service is preferred to be provided by low-side SSVT, local distribution, or on-site generator in that order. The design shall include two (2) fused disconnect switches for the incoming feeds (secondary feed of the SSVT and emergency feed). The system neutral must be bonded to ground in one and only one of the fused disconnects. These two disconnects shall both be in the control building. The normal station power source also needs to have a fused disconnect switch below the station service transformer. The fuses shall be Type LPN.

Also, the unprotected conductors between the normal or backup station service transformers and the first disconnect cannot be routed in the same conduit with feeders or branch circuits.

Appendix 1: Collector Substation

There shall be specified an Automatic Transfer Switch (**ATS**) with microprocessor control. The ATS shall be equipped with alarms for loss of normal service and loss of backup service. The ATS shall be capable of managing a standby generator on the backup source. The ATS shall have neutral bonding provisions.

There shall be specified AC load centers with enough circuit positions for the substation's ultimate configuration. Each AC load center shall be 120/240 VAC, three-wire, single phase, having a 100% rated, main breaker. The final AC load center breaker position and total circuits shall be dictated by the final approved AC Calculation, considering ultimate substation configuration. AC load centers shall be dead-front design, installed on the control building wall, and provided with conduit or wireway access to the cable tray for use by others. The load centers shall use a commonly available circuit breaker type.

11.3 Metering Requirements

The metering panel shall be designed and constructed as specified in the GIA or Project planning phases.

Multi-conductor cables no smaller than #10 AWG shall be used to connect the instrument transformer secondary windings to the meter location. Under no circumstances shall CT cables contain splices. Larger conductor size may be required depending on the location of instrument transformers in relation to the meters. Seller shall perform burden calculations to determine appropriate conductor size.

Conductor used for grounding the metering instrument transformer tank shall be the same size as that used for the ground grid and in no case be smaller than #40 AWG.

Metering CTs and PTs shall be 0.15B1.8 sized so that tapping down is not required and 3% extended range TR=2 respectively.

All meters shall conform to ANSI Standards C12.20, C12.1, and C12.10. Acceptable meters are Landis and Gyr E850 MAXsys Elite, SEL-734 or SEL-735.

11.4 SCADA

A Remote Terminal Unit ("**RTU**") and/or gateway device shall be specified, and installed to provide supervisory control, status indication, alarm monitoring, and to gather accumulated and instantaneous data to be telemetered to Entergy Distribution Operations Center (**DOC**), Transmission Control Center (**TCC**) and Entergy Local Balancing Authority (**LBA**). The RTU shall comply with all GIA requirements.

While all substations require a TCC / DOC RTU to be present, some existing substations host a "dual port" RTU design in which data is provided to a TCC and LBA SCADA host. Confirmation of existing substation RTU-SCADA host configuration shall be done by contacting the IT-OT EMCS SCADA teams and/or IT-OT Substation Services. Substations that serve as a generation interconnection or system tie boundary with another utility may also require a dual-port RTU-SCADA host configuration.

Relay Design Personnel shall perform the following activities per TMM TE-SD-AD-006; RTU/Communication Processor Configuration and Edit Sheet Procedure.

- a) Obtain initial baseline TCC RTU edit sheet from IT OP- Tech Personnel of what the SCADA Host has programmed to date of the request, or latest revision if there are revisions being documented.
- b) Provide SOC and/or GMS personnel needed information for them to provide new updated SOC and/or GMS edit sheets.
- c) Issue final approved TCC, SOC, and/or GMS edit sheets with relay design package.

11.5 Communications

The communications media (pilot wire, fiber optic cable, power line carrier or digital microwave) required, and the communications system for supervisory control, telemetering and equipment status indication will generally be known at the Project initiation stage. Note that Entergy will usually consider digital microwave as adequate communication media. This will vary depending on the interconnection substation communication capabilities and GIA requirements.

Designers of communication circuits shall consider redundant, dual-purpose paths.

A telephone is required to facilitate voice receipt of switching orders, emergency services, and restoration of service during outages.

For fiber optic cable facilities, two conduits from the substation fence to the fiber optic cable terminal board in the control building shall be furnished and installed. The fiber optic cable between the fence and the terminal board shall be installed in conduit(s).

Multiplexers used for fiber-optic interface for digital relay communications schemes system protection shall be hardened per IEEE Std 1613 - IEEE Standard Environmental and Testing Requirements for Communications Networking Devices in Electric Power Substations, and compatible with IEEE Std C37.94 - IEEE Standard for N times 64 kbps Optical Fiber Interfaces between Teleprotection and Multiplexer Equipment.

11.6 Digital Fault Recorder

If the Project requires a Digital Fault Recorder (*DFR*), TESLA 4000 or similar DFR may be used. This shall include enough current and voltage inputs as per Project design.

11.7 Low Voltage Cable (Wiring)

The following is a partial list of the requirements for station power, instrumentation and control cabling within the substation.

- The voltage drop for all control cables shall be verified not to exceed 10%.
- All current carrying control cables shall be sized based on the anticipated maximum load currents. Factors that shall be considered to determine the adequate cable size are conductor material, ambient conditions, cable insulation, cable stranding, proximity of parallel current carrying cables and whether the cables are in conduit, in a cable tray or suspended in the air.
- All low voltage power, instrumentation and control cables within the substation shall be insulated for a 600-volt rating.
- Coaxial and instrumentation cable shall be fully shielded both inside and outside the control house.
- All other control cables inside the control house are not required to be shielded.
- Shielded cables shall be required in 345 kV yards and above (CT, trip and control circuits) and in 69 kV and above capacitor banks (grounded and ungrounded). All control and low voltage power cables outside the control house shall have a longitudinally corrugated copper tape shield.
- Returns for power, currents, potentials, controls, analogs and others shall be within the same cable.
- Cable shields and unused conductors are not required to be terminated or grounded for cables within the control house. For shielded field cables, the shield shall be terminated at one end, preferably within the termination cabinet, and unused conductors shall be left ungrounded. The termination cabinet ground bar shall be sized to accommodate shield grounding.
- Analog connections shall be made with 2 pair #18 AWG instrumentation cable, communication connections shall use shielded 4/C #18 AWG control cable, and status point connections shall use shielded 8/C #18 AWG control cable when new cables are required.

Solar BOT Scope Book: Appendix 1 Collector Substation

Appendix 1: Collector Substation

- Power line carrier signals shall be shielded via a shielded coaxial type cable.
- Splicing of cables is not permitted.

12PHYSICAL AND ELECTRONIC SECURITY

Refer to IEEE Std. 1402 for guidance in providing physical and electronic security for the substation. Additional security design elements may be required by NERC Critical Infrastructure Protection (“**CIP**”) standards.

The following NERC CIP standards provide mandatory security requirements:

- a) CIP-002; Cyber Security – BES Cyber System Categorization
- b) CIP-005; Cyber Security – Electronic Security Perimeter(s)
- c) CIP-006; Cyber Security – Physical Security of BES Cyber Systems
- d) CIP-014; Physical Security

Critical substations are designated as Critical or Deemed Essential (**CODE**). CODE substations include the Critical Asset and infrastructure but also the larger assets which if destroyed, damaged, degraded or otherwise rendered unavailable would have a significant impact on the Bulk Electric System (**BES**) affecting its stability or ability to transport large loads or would have a detrimental impact on the reliability or operability of the electric grid or would cause significant risk to the public health and safety.

NERC CIP-014-1 standard provides the following criteria for critical designation:

- a) All 500 kV substations;
- b) Substations operating at 200 kV to 499 kV with an aggregate weighted value exceeding 3000 per table the below; and
- c) Substations operating at 200 kV and above and connected to three or more substations with an aggregate weighted value exceeding 3000 per the table below:

Voltage of Line	Weight Value per Line
200 kV to 299 KV	700
300 kV to 499 kV	1300

In general, all 500 kV substations, all substations with four 230 kV lines or all substations with three 230 kV and several 161 kV or lower transmission lines may be considered as CODE. The criteria noted above are the minimum threshold for CODE designation. A substation may also be designated CODE as necessary per the unique risks that justify such designation.

Substations that are designated as CODE assets require additional physical and electronic security from physical and electronic intrusion, vandalism as required by NERC CIP-002, -005, and -006.

Additional requirements may exist due to other evolving cyber security concerns. Check with Transmission Planning for site specific concerns.

Minimum security requirements are defined in *Table 29*

Appendix 1: Collector Substation

Table 29: Minimum Security Requirements

Location	Description	Equipment by Seller	Equipment by Buyer
Collector Substation	Minimum two cameras located at opposite corners of substation area	Wiring (power and communications) and required hardware supports	Cameras
	Electrically operated slide gate with keycard reader	Keypad, slide gate, gate operator, wiring (power and communications), grounding loop, exit button and hardware for mounting keycard reader	Keycard reader
Collector Substation Control House	Keycard reader for lock on control house personnel door	Keypad, wiring (power and communications), and required hardware supports for mounting keycard reader	Keycard reader

13 DELIVERABLES

In addition to any submittals and deliverables defined in the Project Contracts, in accordance with NERC reliability standards, Seller shall provide the following documentation to Buyer thirty (30) days prior to initial synchronization of the Project, along with any other documentation reasonably requested by Buyer or required by NERC:

- BAL-005 – One-line diagram that displays the Electrical Interconnection Point (and includes unique line identifiers/names ensuring that the Project Site and Buyer - Transmission use the same naming convention when referring to the Plant (e.g., breakers, lines, etc.) by Seller)
- COM-002 – Network diagram of voice and data links by Seller
- FAC-008 – Identification of most limiting equipment factor based on application of Generator Buyers Facility Rating Methodology by Seller
- MOD-032 – Data for Power System Modeling and Analysis, as applicable, by Seller.
- VAR-002 - Transformer information, including the following, as applicable, by Seller and Buyer (or its Affiliate(s)), and as obtained by Seller from the Approved Vendor of the GSU:
 - Tap settings
 - Available fixed tap ranges
 - Impedance data
 - The + / - voltage range with step-change in % for load-tap changing transformers

Appendix 1: Collector Substation

ATTACHMENT 1: APPROVED MANUFACTURERS LIST FOR COLLECTOR SUBSTATION

Attachment 1 to this Appendix (Collector Substation) provides an Approved Manufacturers List. The Approved Manufacturers List in this Attachment 1 is in addition to the Approved Manufacturers and EPC Contractor List in Appendix 9 (Approved Manufacturers and EPC Contractors List) of this Scope Book.

Description	Preferred Manufacturer	Preferred Supplier	Other Approved Manufacturer(s)
Arrester, Surge	Cooper	Eaton Cooper	Siemens, Hitachi Energy
Battery Fiberglass Enclosure with A/C	Exponential	Exponential Power	
Battery – EC	Enersys	Exponential Power	
Battery – CC	Enersys	Exponential Power	
Battery Charger ATEVO	Hindle	Exponential Power	
Battery Rack	Enersys	Exponential Power	
Bolts Anchor			Valmont, Threaded Fasteners
Bolts Anchor cage for Substation Steel			Valmont, Threaded Fasteners (size limit)
Breaker, MV 15 kV- 27kV	ABB INC. - San Luis Potosi, Mexico	ABB Inc.	MEPPI - Warrendale, PA
Breaker, MV 34.5 kV	ABB INC. - San Luis Potosi, Mexico	ABB Inc.	MEPPI - Warrendale, PA
Breaker, HV 115kV - 40kA (Dead Tank)	Siemens - Richland, MS	Siemens	MEPPI - Warrendale, PA Hitachi Energy - Mt. Pleasant, PA ICO - Changwon, S. Korea
Breaker, HV 115kV - 63kA (Dead Tank)	Siemens - Richland, MS	Siemens	MEPPI - Warrendale, PA Hitachi Energy - Mt. Pleasant, PA HICO - Changwon, S. Korea
Breaker, HV 161kV - 40kA (Dead Tank)	Siemens - Richland, MS	Siemens	MEPPI - Warrendale, PA Hitachi Energy - Mt. Pleasant, PA HICO - Changwon, S. Korea
Breaker, HV 161kV - 63kA (Dead Tank)	Siemens - Richland, MS	Siemens	MEPPI - Warrendale, PA Hitachi Energy - Mt. Pleasant, PA HICO - Changwon, S. Korea
Breaker, HV 245kV-63ka (Dead Tank)	Siemens - Richland, MS	Siemens	MEPPI - Warrendale, PA Hitachi Energy - Mt. Pleasant, PA HICO - Changwon, S. Korea
Breaker, HV 69kv (Dead Tank)	Siemens - Richland, MS	Siemens	MEPPI - Warrendale, PA Hitachi Energy - Mt. Pleasant, PA HICO - Changwon, S. Korea
Breaker, HV 245KV, 80ka (Dead Tank)	Siemens - Richland, MS	Siemens	MEPPI - Warrendale, PA Hitachi Energy - Mt. Pleasant, PA HICO - Changwon, S. Korea
Breaker, HV 69-245 (Live Tank)			Hitachi - Ludvika, Sweden Siemens - Jundiai, Brazil (245 kV only)
Breaker, EHV 345/500kV (Dead Tank)	MEPPI - Warrendale, PA	MEPPI	Hitachi Energy - Mt. Pleasant, PA Siemens (345KV ONLY) - Richland, MS HICO - Changwon, S. Korea
Breaker, EHV 345/500kV (Live Tank)			Hitachi Energy - Ludvika, Sweden Siemens - Jundiai, Brazil
Bus, Aluminum Pipe	Three D Metals	Three D Metals	AFL

Appendix 1: Collector Substation

ATTACHMENT 1: APPROVED MANUFACTURERS LIST FOR COLLECTOR SUBSTATION

Description	Preferred Manufacturer	Preferred Supplier	Other Approved Manufacturer(s)
Control Cable -Shielded and Non-Shielded	Southwire	Southwire	Priority, Lake Cable, Service Wire, Prysmian
Capacitor Cans			Cooper, GE, Hitachi Energy
Capacitor Banks, Shunt			Cooper, GE, Hitachi Energy
Capacitor Banks, Series			Hitachi Energy, MEPPI, Siemens
Capswitcher 115kV and above	Southern States	Preferred Sales	
Capswitcher 245kV - 362kV	Southern States	Preferred Sales	
Capswitcher 34.5kV and below	Southern States	Preferred Sales	
Capswitcher 69kV	Southern States	Preferred Sales	
Power line Carrier UPLC		Ametek	Pulsar
CCVT 69kV - 500kV	Ritz - Lavonia, GA	Aertker	GE - Charleroi, PA, Itajuba, Brazil Trench - Toronto, Canada Hitachi Energy - Crystal Springs, MS Arteche - Tepeji Del Rio, Mexico
Chain Wall	Kenner Chain Wall		
Circuit Switcher Mark V	S&C	Curtis Stout	Southern States
Circuit Switcher Vertical Standing	S&C (Series 2000)	Curtis Stout	Southern States
Cable, Aluminum ACSS, ACSR	Prysmian	Aertker co	Southwire
Cable, Copper (Not Control cable)		Stuart Irby	Copperweld /Alcoa
Cable, Fiber ADSS		Preferred Sales	AFL
Cable, Fiber OPT-GW		Preferred Sales	AFL
Conduit & Accessories		Stuart Irby	Cantex, Carlon
Connectors line ACSS		Preferred Sales	AFL
Connectors line (Fiber, OPGW, ACSR)		Preferred Sales	AFL
Connectors, Trans. Line - Insulator Assemblies	Maclean Power Sys	Preferred Sales	
Connectors/Fittings - Substation		Stuart Irby	Any Approved Manufacturer
Control House	Modular Connections	Modular Connections	AZZ Inc. (Avail), Trachte, VFP
Control House Drop-In (turnkey)	VFP	VFP	
CT Slipover only		ITEC	ITEC, ABB Inc., Meramec
CT 15kV - 34.5kV			ABB Inc, Ritz
CT 230kV			GE - Charleroi, PA, Itajuba, Brazil Trench - Toronto, Canada Ritz - Waynesboro, GA. Arteche - Tepeji Del Rio, Mexico

Appendix 1: Collector Substation

ATTACHMENT 1: APPROVED MANUFACTURERS LIST FOR COLLECTOR SUBSTATION

Description	Preferred Manufacturer	Preferred Supplier	Other Approved Manufacturer(s)
CT 345kv - 500kV			GE - Charleroi, PA, Itajuba, Brazil Trench - Toronto, Canada Arteche - Tepeji Del Rio, Mexico
CT 69kv - 161kv			GE - Charleroi, PA, Itajuba, Brazil Trench - Toronto, Canada Hitachi Energy - Crystal Springs, MS Ritz - Waynesboro, GA Arteche - Tepeji Del Rio, Mexico
CT High Accuracy Extended Range			GE - Charleroi, PA, Itajuba, Brazil Trench - Toronto, Canada Hitachi Energy - Crystal Springs, MS Ritz - Waynesboro, GA Arteche - Tepeji Del Rio, Mexico
DFR (Digital Fault Recorder)			MehtaTech - Louisiana, Mississippi, Arkansas only
DFR (Digital Fault Recorder)			Qualitrol - Texas only
Firewall			Durasystems, Modular, Oldcastle
Conductor Fittings Compression		Stuart Irby	AFL, Sefcor, Anderson, Hubell
Below grade Grounding connectors - Weld	Cadweld		Thermoweld
Below grade Grounding connectors - Swage			AFL
Ground Rods, Clamps, & Anodes		Stuart Irby	Any Approved Manufacturer
Helical Foundation Piling			Hubbell, Cyntech
Insulator, Station Post, Porcelain 34.5kV and below	Vanguard	Preferred Sales	Victor, Lapp, NGK, Newell, PPC, Hubbell
Insulator, Station Post, Polymer 15kV - 230kV	Maclean Power Sys	Preferred Sales	
Insulator, Station Post, Porcelain 161kV	Hubbell	Hubbell Power Systems	Victor, Lapp, NGK, Newell, Vanguard, PPC
Insulator, Station Post, Porcelain 230kV STANDARD STRENGTH	Hubbell	Hubbell Power Systems	Victor, Lapp, NGK, Newell, Vanguard, PPC
Insulator, Station Post, Porcelain 230kV HI / EXTRA HIGH STRENGTH			Hubbell, Victor, Lapp, NGK, Newell, Vanguard, PPC
Insulator, Station Post, Porcelain 345/500kV HI / EXTRA HIGH STRENGTH			Hubbell, Victor, Lapp, NGK, Newell, Vanguard, PPC
Insulator, Station Post, Porcelain 69kV, 115kV	Hubbell	Hubbell Power Systems	Victor, Lapp, NGK, Newell, Vanguard, PPC
Insulator, Line, Polymer	Maclean Power Sys	Preferred Sales	
Insulator, Line, Polymer (Insulator Assembly)	Maclean Power Sys	Preferred Sales	

Solar BOT Scope Book: Appendix 1 Collector Substation

Appendix 1: Collector Substation

ATTACHMENT 1: APPROVED MANUFACTURERS LIST FOR COLLECTOR SUBSTATION

Description	Preferred Manufacturer	Preferred Supplier	Other Approved Manufacturer(s)
Insulator, Line, Polymer (Insulator Only)	Macleam Power Sys	Preferred Sales	Newell
Insulator, Line, Polymer (Hardware Assembly Only)	Macleam Power Sys	Preferred Sales	
Interrupter		Curtis Stout	S&C
Interrupter, Joslyn		Ruffin	Joslyn
Interrupter Switches LLS I	Southern States	Preferred Sales	
Interrupter Switches LLS II	Southern States	Preferred Sales	
Interrupter Whip	Southern States	Preferred Sales	
Junction Boxes			MMR, Premier Control, SEL
Lighting - LED	Acuity	Ruffin & Associates	
Panel - Battery Switching			MMR, SEL, Premier Control
Panel - Breaker Line			MMR, SEL, Premier Control
Panel - Communication rack			MMR, SEL, Premier Control
Panel - Meter			MMR, SEL, Premier Control
Panel - AC & DC Cabinets			MMR, SEL, Premier Control, Peterson Panel
Panel - Bus Differential			MMR, SEL, Premier Control
Panel - Line Protection			MMR, SEL, Premier Control
Pole Caissons T-Line - after approval	Valmont	Preferred Sales	
Pole, Steel after approval	Valmont	Preferred Sales	
Pole, Concrete	Valmont	Preferred Sales	
PT 15kV - 34.5kV			ABB Inc, GE, Ritz
PT 69kv - 230kv			GE - Charleroi, PA, Itajuba, Brazil Trench - Toronto, Canada Hitachi Energy - Crystal Springs, MS Arteche - Tepeji Del Rio, Mexico
Reactor, Limiting			Coil Innovations - Eferding, Austria Trench - Toronto, Canada
Reactor, Dry Type Shunt Below 230kV			Coil Innovations - Eferding, Austria Trench - Toronto, Canada
Reactor, Oil filled Shunt Through 500kV			Hitachi – Varennes, Canada; Guarulhos, Brazil Mitsubishi – Ako, Japan Prolec-GE Waukesha – Canoas, Brazil Siemens – Jundiai, Brazil; Nuremburg, Germany; Weiz, Austria SMIT – Nijmegen, Netherlands

Appendix 1: Collector Substation

ATTACHMENT 1: APPROVED MANUFACTURERS LIST FOR COLLECTOR SUBSTATION

Description	Preferred Manufacturer	Preferred Supplier	Other Approved Manufacturer(s)
3-ph station-class voltage regulators For replacement of existing 3-ph station-class regulators; For use with SN0102 Small Transformers in new installations (when approved)			Delta Star – Lynchburg, VA, USA PTTI – Raeford, NC, USA Virginia Transformer – Roanoke, VA, USA
SEL Relay cables Cable & Fiber		Power Connection	SEL
SEL Relays		Power Connection	SEL
ACS RTU Cables NTX		Ruffin & Associates	ACS (Automated Control Systems)
ACS RTU – Peripherals NTX-U20 & Upgrades		Ruffin & Associates	ACS (Automated Control Systems)
GE RTU Parts Accessories & Cables		Perferred Sales	G.E. Grid Solutions
RTU IO cabinet standard RTU		Perferred Sales	G.E. Grid Solutions
RTU - Kits & Parts D400, D20, DNPIO Kits & Parts		Perferred Sales	G.E. Grid Solutions
Rupters/S&C ALDUTI 15 kV Vac	S&C	Curtis Stout	
Signs - General		Stuart Irby	Stuart Irby
Signs - Entergy Substation Switchyard		Impco	Impco
Structure, Tapered Tubular Fabrication and Design	Distran	Distran	Valmont
Structure, Standard Shape Fabrication only (existing details)	Distran	Distran	Industrial Steel, Valmont
Structure, Standard Shape Fabrication and Design	Distran	Distran	Industrial Steel, Valmont
Structure, Tapered Tubular Fabrication only (existing details)	Distran	Distran	Valmont
Switch, Fuse (SMD style) 15 kV	S&C	Curtis Stout	
Switch, T-Line group operated 245kV and below		Southern Utility Sales Agency	SEECO
ASCO ATS (Automatic Transfer Switch)			Utility and Industrial Supply,LLC, WESCO
Switch, Disconnect 15kV - 34.5kV	Southern States	Preferred Sales	USCO

Appendix 1: Collector Substation

ATTACHMENT 1: APPROVED MANUFACTURERS LIST FOR COLLECTOR SUBSTATION

Description	Preferred Manufacturer	Preferred Supplier	Other Approved Manufacturer(s)
Switch, Disconnect, Hookstick 15kV - 34.5kV PBO up to 2000A XY-2A at 3000A	Southern States	Preferred Sales	USCO
Switch, Disconnect 115 & 230kV Air Break	Southern States	Preferred Sales	USCO, Pascor Atlantic
Switch, Disconnect 69kV - 230kV	Southern States	Preferred Sales	USCO, Pascor Atlantic
Switch, Disconnect 69kV Air Break	Southern States	Preferred Sales	USCO, Pascor Atlantic
Switch, Disconnect 345/500kV	Southern States	Preferred Sales	Pascor Atlantic
Switch, Motor Operator S&C MO	S&C	Curtis Stout	
Switch, Motor Operator Southern States MO	Southern States	Preferred Sales	
Gas Insulated Switchgear 69 kV- 500kV			MELCO - Itami, Japan Hitachi Energy - Oerlikon, Switzerland Siemens (345KV and below) - Berlin, Germany HICO - Changwon, S. Korea
Metal-Clad Switchgear below 34.5kV			Powell – Confirm Approved Factory prior to bid selection Eaton - Confirm Approved Factory prior to bid selection
Transformer HV 69kV and below//7.5 MVA (base) and below/non- LTC	Prolec- GE/Prolec-GE Waukesha - Goldsboro, NC USA	Aertker Co.	Delta Star - Lynchburg, VA USA Prolec-GE/Prolec-GE Waukesha - Goldsboro, NC, USA; Waukesha, WI, USA Hitachi Energy - Crystal Springs, MS USA PTTI - Raeford, NC Virginia Transformer - Roanoke, VA
SSVT; Station Service Voltage Transformer (Oil Filled) 230kV			Trench - Toronto, Canada Hitachi Energy - Crystal Springs, MS Arteche - Tepeji Del Rio, Mexico
SSVT; Station Service Voltage Transformer (Oil Filled) 46kV -161kV		Hitachi 46	Trench - Toronto, Canada Hitachi Energy - Crystal Springs, MS Arteche - Tepeji Del Rio, Mexico
SSVT; Station Service Voltage Transformer (SF6 Filled) 230 - 500kV			Trench - Bamberg, Germany Hitachi Energy - Lodi, Italy
Transrupter II	S&C	Curtis Stout	
Trap, Line Carrier		Curtis Stout	Trench (No other supplier approved)
Trench	Concast	GHMR	Trenway, Old Castle
Tuner, Line Carrier		Curtis Stout	Trench

Appendix 1: Collector Substation

ATTACHMENT 1: APPROVED MANUFACTURERS LIST FOR COLLECTOR SUBSTATION

Two – Winding GSU Transformers rated $\geq 100\text{MVA}$ (3-phase); HV $\geq 115\text{ kV}$				
OEM	Location	Qualified	Maximum deliverable ratings	
			MVA	kV
ABB	Varenes, Qubec, Canada; Guarulhos, Brazil; Cardoba, Spain	Yes; No, India Manufacturer		500
GE/Waukesha Electric (SPX)	Waukesha, WI, USA Goldsboro, NC, USA	Yes; No, Mexico Manufacturer	400	345
JST	Lyon, France	Yes	1200	500
Mitsubishi	Ako, Japan	Yes	1500	1000
Siemens	Linz & Weiz Austria; Nuremberg, Germany; Jundia, Brazil; Bogata/Tenjo, Columbia	Yes; No Mexico Manufacturer		
SMIT	Nijmegen, Netherland	Yes	500	500

Two/Three – Winding Auxiliary, Reserve & Station-Service Transformers rated $\leq 100\text{MVA}$ (3-phase); HV $\leq 230\text{ kV}$				
OEM	Location	Qualified	Maximum deliverable ratings	
			MVA	kV
ABB/Kulman	Crystal Springs, MS, USA	Yes	100	161
ABB	Bland, VA, USA	Yes	100	100
Delta Star	Lynchburg, VA, USA	Yes	60	230
GE/Waukesha Electric (SPX)	Waukesha, WI, USA	Yes; No Mexico Manufacturer	100	230
JST	Lyon, France	Yes	100	230
Mitsubishi	Ako, Japan	Yes		
Siemens	Linz & Weiz Austria; Nuremberg, Germany; Jundia, Brazil; Bogata/Tenjo, Columbia	Yes; No Mexico Manufacturer		
SMIT	Nijmegen, Netherland	Yes		

Appendix 1: Collector Substation

ATTACHMENT 1: APPROVED MANUFACTURERS LIST FOR COLLECTOR SUBSTATION

ENTERGY APPROVED HV CIRCUIT BREAKER MODEL NUMBERS						
Voltage (kV)	Continuous Current (A)	Interrupting Rating (kA)	Siemens Breaker to be ordered	CT Ratio and Accuracy	CT Quantity (per bushing)	
230	3000	50	SPS2-245-50-3000	3000:5 C800	3	
		63	SPS2-245-63-3000 (reference)	3000:5 C1200	3	non-standard
161	3000	40	SPS2-170-40-3000	3000:5 C800	3	
		63	SPS2-170-63-3000 (reference)	3000:5 C1200	3	non-standard
138	3000	40	SPS2-145-40-3000	3000:5 C800	2	
		63	SPS2-145-63-3000 (reference)	3000:5 C1200	2	non-standard
115	3000	40	SPS2-145-40-3000	3000:5 C800	2	
		63	SPS2-145-63-3000 (reference)	3000:5 C1200	2	non-standard
69	3000	40	SPS2-72.5-40-3000	3000:5 C800	2	
		63	SPS2-145-63-3000 (reference)	3000:5 C1200	2	non-standard

Appendix 1: Collector Substation
ATTACHMENT 2: PROJECT SITE ENVIRONMENTAL CHARACTERISTICS

The Project Site environmental data that Seller shall use for the design of the Collector Substation shall have been determined prior to bid submission. The minimum required Project Site environmental data to be included is shown in Table 2-1 below. This Table 2-1 shall have been completed by Seller and included with the bid. Additional pertinent criteria shall be provided as needed.

Table 2-1. Project Site Environmental Characteristics

Description	Data (Units)
Elevation (substation)	
Contamination Level (light, medium, heavy, extra heavy) *	
Average Annual Temperature	
Average High Temperature	
Extreme High Temperature	
Average Low Temperature	
Extreme Low Temperature	
Average Annual Precipitation	
Maximum 24-hour Rainfall	
Maximum 1-hour Rainfall	
Maximum 24-hour Snowfall	
Ground Snow Load	
Design Ice Load	
Design Wind Speed	
Isokeraunic Level	
Seismic Referenced Code	
Mapped Spectral Response Acceleration at Short Period (0.2- Second) S_s	
Mapped Spectral Response Acceleration at 1-Second Period S_1	
Site Class	
Seismic Design Category	

*All equipment external bushing creepage distance shall be based on this criterion. If not available, medium contamination (35mm/kV) shall be used. This factor is applied to nominal line to ground voltage.



Solar BOT Scope Book

Appendix 2

High Voltage Overhead Transmission

REVISION RECORD			
Revision No.	Approval Date	Section / Page Revised	Reason / Description of Change
0	9/14/2023	All	Initial Issue
25-1	5/19/2025	All	Editorial Corrections
26-1	3/3/2026	All	Editorial Corrections

Appendix 2: High Voltage Overhead Transmission

TABLE OF CONTENTS

1	INTRODUCTION.....	6
	1.1 Purpose	6
	1.2 Scope	6
	1.3 General Data.....	6
	1.4 Deviations	6
2	DEFINITIONS	7
	2.1 Definitions	7
	2.2 Acronyms and Abbreviations	7
3	REFERENCES AND DOCUMENTS.....	8
	3.1 Industry Standards	8
	3.1.1 Materials.....	9
4	SAFETY AND ENVIRONMENT.....	9
	4.1 Safety	9
	4.2 Avian Design	9
	4.3 Future Impacts	10
5	LOAD COMBINATIONS.....	10
	5.1 Loading Combinations	10
	5.1.1 District Maps	10
	5.1.2 Load Cases - Summary	10
	5.1.3 Loads – Structure Analysis	11
	5.1.4 Stringing Loads on Custom Davit and Cross Arms	11
	5.1.5 NESC Load Cases with OCF = 1.0.....	11
	5.1.6 Special Load Cases - Structure Analysis.....	11
	5.1.7 Single Dead-End and Failure Containment (Dead-End Structures)	11
	5.1.8 Stringing Longitudinal Unbalanced Load (Tangents & Run. Angles)	11
	5.1.9 Pole without Conductors (NESC 261A1c) (Guyed Poles)	11
	5.1.10 Stringing loads on Dead-Ends	11
	5.1.11 PLS Wind Direction for Structure Loading	12
	5.2 Load Cases – Clearance Verification.....	12
	5.3 Load Cases – Wire Stringing	12
	5.4 Load Factor and Strength Reduction	13
6	CLEARANCE AND RIGHT OF WAY REQUIREMENTS.....	14
	6.1 Vertical Clearance – Over Ground.....	14

BESS BOT Scope Book: Appendix 2 High Voltage Overhead Transmission

Appendix 2: High Voltage Overhead Transmission

6.2	Other Vertical Clearances	14
6.2.1	Supply Conductors (69 kV and above)	14
6.2.2	Substations	15
6.2.3	Miscellaneous	15
6.3	Horizontal Clearance.....	15
6.3.1	Adjacent Supply Lines	15
6.3.2	Adjacent Buildings and other Structures.....	15
6.3.3	Insulator/Conductor Swing Clearance	15
6.3.4	Right of Way Requirements	16
7	CONDUCTOR AND SHIELD WIRE INFORMATION	21
7.1	Entergy Standard Conductors.....	21
7.2	Standard Shield Wires	23
7.3	Standard Optical Ground Wires	24
7.4	Bundled Conductors.....	24
7.4.1	Bundled Conductors (New Construction, excluding 500 kV).....	24
7.4.2	Bundled Conductors (500 kV).....	25
7.5	Sag and Tension Limitations.....	25
7.5.1	NESC Tension Limits.....	25
7.5.2	Tension Limits for Vibration Control.....	25
7.5.3	Vibration Control for Long Spans Exceeding the Ruling Span	27
7.6	Correction to Sag when Final Installation is Interrupted	27
7.7	Galloping	27
7.8	Aeolian Vibration	27
7.9	Conductor Corona.....	27
7.10	ACSS and ACSS/TW Conductor	28
7.10.1	ACSS Sags – Tensions - Stringing	28
7.11	Fiber Optic/Shield Wire Requirements.....	28
7.11.1	Fiber Optic Details.....	28
7.11.2	Splice Box Locations.....	28
7.12	SW Sagging Relative to Conductors.....	28
7.13	Conductor and Shield Wire Marking	29
7.13.1	Aerial Patrol Marking.....	29
7.13.2	Marking for Federal Aviation Administration (FAA) regulations.....	29
7.13.3	Navigable Waterway Marking	29
7.13.4	Avian	29

Appendix 2: High Voltage Overhead Transmission

	7.13.5 Slow-Moving Vehicle Signs.....	29
	7.13.6 Spiral Vibration Dampers (Yellow)	29
	7.13.7 QuikMark Devices	30
	7.13.8 QuikMark Devices Combined with Spiral Vibration Dampers.....	30
8	OTHER ELECTRICAL CRITERIA	30
	8.1 Electrical Insulation	30
	8.1.1 Insulator Swing.....	30
	8.2 Transmission Line Lightning Protection Design.....	33
	8.2.1 Reference Guides	33
	8.2.2 GFD.....	33
	8.2.3 Structure BIL	34
	8.2.4 Shield Wire Installation	34
	8.2.5 Shield Wire Type and Size.....	34
	8.2.6 Shielding Angle	34
	8.2.7 Maximum Grounding Resistance	34
	8.2.8 Lightning Arrestors	34
	8.3 Grounding and Cathodic Protection.....	35
	8.3.1 Grounding	35
	8.3.2 Cathodic Protection.....	36
	8.3.3 Structure Protection	37
9	STRUCTURE DESIGN CRITERIA	37
	9.1 Steel Poles	37
	9.1.1 Tubular Steel Pole Purchase Specification.....	37
	9.1.2 General Design Requirements.....	37
	9.1.3 Procurement.....	39
	9.1.4 Structure Hardware	39
	9.1.5 Grounding and Cathodic Protection.....	39
	9.1.6 Hybrid Structures	39
	9.2 Concrete Poles.....	39
	9.2.1 Spun Pre-stressed Concrete Pole Purchase Specification	39
	9.2.2 General Design Requirements.....	40
	9.2.3 Procurement.....	41
	9.2.4 Structure Hardware	41
	9.3 H-Frame Design.....	41

Appendix 2: High Voltage Overhead Transmission

	9.3.1	Structure Types	41
	9.3.2	Cross Arm Design	41
	9.3.3	Cross Arm Assembly Details	42
	9.3.4	Rock Anchors	42
	9.3.5	Expanding Rock Anchors	42
	9.3.6	Grouted Rock Anchors	42
	9.3.7	Guying Hardware	43
	9.3.8	Guyed Structure Limitations	44
	9.4	Spacing of Dead-End Structures	45
	9.5	Considerations at Major Crossings	45
10		STRUCTURE FOUNDATIONS	46
	10.1	Soil Information	46
	10.2	Design Methodology – Lateral Load	47
		10.2.1 Program Description	47
		10.2.2 General Acceptance Criteria	47
	10.3	Foundation Types	47
		10.3.1 Basic Foundation Types	47
		10.3.2 Grounding and Cathodic Protection	48
11		Attachments	48

1 INTRODUCTION

1.1 Purpose

This Appendix to the Scope Book provides design requirements and reference material for the design of the High Voltage (**HV**) (69 kV and above) overhead transmission lines that will be built and/or connected to the Entergy transmission system by or for Seller as part of the Project (Transmission Lines). This document pertains to the transmission line between the collector substation and the deadend structure delivered by the GIA. This document is intended to provide to Seller and others acting at Seller's request requirements, recommendations, and guidance in the planning, design, construction, asset management, use, and operation of the Transmission Lines.

1.2 Scope

This Appendix applies to all Transmission Lines.

This Appendix primarily describes technical requirements, both performance-based and prescriptive for the design and installation of the Transmission Lines. Refer to the Scope Book and other parts of the Agreement for information regarding project sequencing and milestones, the project execution plan, project schedule and schedule management, project controls reporting, health and safety information, factory acceptance tests, training, required submittals, design reviews, equipment records, specified deliverables, project documentation, and other relevant matters not covered by this Appendix.

1.3 General Data

This Appendix addresses aspects of the Work relating to the Transmission Lines. It is not intended to be, and shall not be construed to be, a comprehensive list of each and every element or other requirement applicable to the Work and shall in no way limit Seller's obligations under the Agreement or any Ancillary Agreement. Without limiting the other terms of the Agreement or any Ancillary Agreement, in performing the Work relating to the Transmission Lines, Seller shall comply with, and cause its Contractors and Subcontractors to comply with, the terms of this Appendix, all Laws (including codes) and applicable Permits.

This Appendix provides the minimum functional specification (**MFS**) for the Transmission Lines, including scope and design requirements. In addition to the requirements set forth in the Agreement (including the Scope Book), the Transmission Lines shall comply with all requirements specified in the GIA or any other Required Deliverability Arrangement.

Article, Section, Table, Figure, and Attachment references in this Appendix are to this Appendix unless otherwise provided or the context otherwise requires.

1.4 Deviations

Any deviations from the MFS for the Transmission Lines or the terms of this Appendix shall require Buyer's prior approval and will be subject to the terms of the Agreement.

2 DEFINITIONS

2.1 Definitions

BIL - Basic Lightning Impulse Insulation Level is a reference insulation level in terms of the crest voltage of a standard lightning impulse.

Conductor Displacement - With respect to clearances, conductor displacement is the conductor movement, including the effects of insulator swing and structure deflection, due to a prescribed ice, wind, or thermal load case. With respect to Right-Of-Way (**ROW**) determinations, conductor displacement is the maximum horizontal conductor displacement from its initial unloaded position, including the effects of insulator swing and structure deflection due to the extreme wind load case. See also (WCD) in Figure 6.3.4.1-3.

Conductor Movement Envelope - With respect to clearances, the conductor movement envelope is the full range of conductor positions in the prescribed ice, wind, or thermal load cases. With respect to ROW determinations, the conductor movement envelope is the full range of conductor movement, including the effects of insulator swing and structure deflection due to the extreme wind load case applied from both directions, and including the initial effective structure width. See also (WCME) in Figure 6.3.4.1-3.

Designer – Individual (in-house or contractor) responsible for analyzing and selecting transmission line components, structures, or foundations.

Effective Structure Width – the width between a structure’s outboard conductors (e.g., for an H-frame configuration, it is twice the phase spacing, and for a vertical conductor configuration it is effectively zero). See also (wS) in Figure 6.3.4.1-3.

LIDAR (Light Detection and Ranging) – A method of detecting and determining the position, velocity, or other characteristics of distant objects by analysis of pulsed laser light reflected from the surfaces of such objects.

Meridian – Electronic document management system used to archive transmission standards and documents and track revisions.

PLS-CADD – A software package used during optimization of pole spotting, design analysis, and the development of material lists.

Vegetation Management Width – Right of way width outside of the conductor movement envelope, purchased solely for establishment of a vegetation management cycle. See (WVM) in Figure 6.3.4.1-1 and Figure 6.3.4.1-2.

2.2 Acronyms and Abbreviations

ACAR	Aluminum Conductor Alloy Reinforced
ACCC	Aluminum Conductor Composite Core
ACCR	Aluminum Conductor Composite Reinforced
ACSR	Aluminum Conductor Steel Reinforced
ACSS	Aluminum conductor Steel Supported
BIL	Basic Lightning Impulse Insulation Level
EPRI	Electric Power Research Institute
FAA	Federal Aviation Administration
FAD	Foundation Analysis & Design

Appendix 2: High Voltage Overhead Transmission

GFD	Ground Flash Density
IEEE	Institute of Electrical and Electronics Engineers
LIDAR	Light Detection and Ranging
MFAD	Moment Foundation Analysis & Design
MVATD	Minimum Vegetation Action Threshold Distance
MVCD	Minimum Vegetation Clearance Distance
NESC	National Electrical Safety Code
OCF	Overload Capacity Factor
ROW	Right of Way
SRF	Strength Reduction Factor
UBS	Ultimate Breaking Strength

3 REFERENCES AND DOCUMENTS

3.1 Industry Standards

The following Industry Standards are referenced in this Appendix:

ASCE MOP 91	Design of Guyed Electrical Transmission Structures
ASCE MOP 123	Prestressed Concrete Transmission Pole Structures
ASCE 48	Design of Steel Transmission Pole Structures
ASCE 74	Guidelines for Electrical Transmission Line Structural Loading
ANSI C2	National Electric Safety Code (NESC)
IEEE Std 80	IEEE Guide for Safety in AC Substation Grounding
IEEE Std 524	Guide to the Installation of Overhead Transmission Line Conductors
IEEE Std 738	Standard for Calculating the Current-Temperature of Bare Overhead Conductors
IEEE Std 1313.2	Guide for the Application of Insulation Coordination
IEE Std 1542	Guide for Installation, Maintenance, and Operation of Irrigation Equipment Located Near or Under Power Lines
APLIC 2012	Reducing Avian Collisions with Power Lines – State of the Art– 2012
APLIC 2006	Suggested Practices for Avian Protection on Power Lines
NACE RP0177	Mitigation of Alternating Current and Lightning Effects of Metallic Structures and Corrosion Control System
OSHA Std 2207, Part 1926	Safety and Health Regulations for Construction
IEEE 738	Standard for Calculating Current-Temperature Relationship of Bare Conductors

Appendix 2: High Voltage Overhead Transmission

IEEE Std. 1243-1997	Guide for Improving the Lightning Performance of Transmission Lines
EPRI	Handbook for Improving Overhead Transmission Line Lightning Performance
EPRI	AC Transmission Line Reference Book - 200kV and Above
EPRI	Guide for Transmission Line Grounding
EPRI	Outline of Guide for Application of Transmission Line Surge Arrestors – 42 to 765 kV
	Pre-stressed Concrete Institute Guide Specifications
	FAA Advisory Circular AC 70/7460-1K, Obstruction Marking and Lighting

The latest issued Standards and Codes at the issuance of the effective date of the Agreement shall be used. Earlier editions are not allowed unless specifically identified in this Appendix.

If a revision to a standard or code is issued, it is not required to be implemented unless the Authority Have Jurisdiction (**AHJ**) has adopted it, in which case, Seller is obligated to any increased compliance above what is required by the Standards and Codes at the effective date of the Agreement. This risk is borne by Seller.

3.1.1 Materials

Seller shall use the descriptions of materials set out in the standard drawings provided in Attachment 1 along with the Approved Vendor List in Attachment 5 to procure the equipment, materials, systems, and other items required for the development, engineering, design, procurement, construction, testing, commissioning, use, and operation of the Transmission Lines in accordance with the terms of the Agreement.

4 SAFETY AND ENVIRONMENT

4.1 Safety

The safety of individuals, the Project, and other life or property in the development, engineering, design, procurement, construction, testing, commissioning, use, and operation shall be the Designer's highest priority.

4.2 Avian Design

The primary issues to consider for avian protection on transmission lines are clearances, marking, and nests. Transmission clearances for all voltages shall exceed the established minimums, shown in Where Entergy standard structure configurations, shown in Attachment 2, are used, the design will meet the guidelines. Marking of wires is addressed in Section 7.13.4 and is to be done only in areas where such marking is required by authorized wildlife agencies, Laws, or applicable Permits.

Appendix 2: High Voltage Overhead Transmission

4.3 Future Impacts

Proper consideration shall be given to working space and access during siting to address direct impacts on both work safety and the need for environmental remediation. Similarly, proper consideration shall be given to the ability to re-conductor a line vs. rebuilding to address the potential considerable ecological benefits.

5 LOAD COMBINATIONS

5.1 Loading Combinations

This section covers the transmission line load cases and load case combinations to be used in the design of the Transmission Lines for the Project. It also includes the Overload Capacity Factors (**OCF**) and Strength Reduction Factors (**SRF**) used to calculate forces on the individual components of each structure within the Transmission Lines. The load combinations below are consistent with the loading requirements of NESC Rule 250; however, the boundaries for loading areas have been shifted from those in NESC Rule 250. All references to NESC 250B, 250C, and 250D refer to the District Loading, Extreme Wind, and Concurrent Ice and Wind as modified based on these shifts in loading areas.

5.1.1 District Maps

Based on the NESC figures, districts were established along county and parish boundaries which envelope the NESC requirements. These boundaries were further modified to address other commitments and past operating experience. Notably: several coastal parishes and counties have design wind speeds increased to 150 mph to address hardening study recommendations and other commitments; roughly the NW half of Arkansas has been treated as NESC Heavy rather than NESC Medium based upon past operating experience and design practice; and the 1 inch ice loading was extended throughout Arkansas and much of northern Mississippi based on extensive damage from past ice storms. They are collectively presented as Attachment 5 illustrating the enveloping districts as follows:

Transmission Line Designers shall use the most conservative loading requirements required along the entire line if the line crosses several counties or parishes requiring different loadings. Exception to this requirement may be taken where a containment structure is placed at the district boundary.

5.1.2 Load Cases - Summary

Table 5.1.2 summarizes the various load cases used to design and analyze structures.

Table 5.1.2 – Structural Load Cases

Description	Wind Loading	Ice Loading	Temperature	NESC Ref.
NESC 250B District Loading				
Heavy	4 psf	0.50 in.	0°F (-20°C)	250B, Table 250-1
Medium	4 psf	0.25 in.	15°F (-10°C)	250B, Table 250-1
Light	9 psf	0.00 in.	30°F (-1°C)	250B, Table 250-1
NESC 250C Extreme Wind				
100 mph	25.6 psf	0.00 in.	60°F (15°C)	250C, Table 250-1
110 mph	31.0 psf	0.00 in.	60°F (15°C)	250C, Table 250-1
125 mph	40.0 psf	0.00 in.	60°F (15°C)	250C, Table 250-1
140 mph	50.2 psf	0.00 in.	60°F (15°C)	250C, Table 250-1
150 mph	57.6 psf	0.00 in.	60°F (15°C)	250C, Table 250-1

Solar BOT Scope Book: Appendix 2 High Voltage Overhead Transmission

Appendix 2: High Voltage Overhead Transmission

Description	Wind Loading	Ice Loading	Temperature	NESC Ref.
NESC 250D Concurrent Ice and Wind				
0.5 in.	2.3 psf	0.50 in.	15°F (-10°C)	250D, Table 250-1
0.75 in.	2.3 psf	0.75 in.	15°F (-10°C)	250D, Table 250-1
1.0 in.	2.3 psf	1.00 in.	15°F (-10°C)	250D, Table 250-1
Cold Case – Uplift	0 psf	0.00 in.	0°F (-20°C)	
Every Day – Deflection	0 psf	0.00 in.	60°F (15°C)	
Unbalanced	See Section 5.1.4	See Section 5.1.4	60°F (15°C)	See Section 5.1.4

5.1.3 Loads – Structure Analysis

In addition to the cases in Table 5.1.2, the following load cases shall be used in the analysis and structure design of all Transmission Line structures.

5.1.4 Stringing Loads on Custom Davit and Cross Arms

For arms, the everyday load case shall include a vertical load of 5000 lbs. suspended from the ends of each arm (to address vertical construction loads). The described vertical load is an allowance for steep stringing angles and other construction loads.

5.1.5 NESC Load Cases with OCF = 1.0

In addition to the standard NESC Overload Capacity Factors, all concrete structures shall have loads applied for NESC Load Cases with OCF = 1.0.

5.1.6 Special Load Cases - Structure Analysis

The following load cases shall be used in the analysis and structure design of the following structure types.

5.1.7 Single Dead-End and Failure Containment (Dead-End Structures)

All wires up, One Side Only Loading, Initial or Final Condition using the Structural Load Cases in Table 5.1.2.

5.1.8 Stringing Longitudinal Unbalanced Load (Tangents & Run. Angles)

0 mph Wind & 0 inch Ice, 60°F (15°C), Initial (Everyday Loads) with 3000 lb. Longitudinal Force (1000 lb. per phase) or with 2000 lb. Longitudinal Force per conductor (H-Frames only).

5.1.9 Pole without Conductors (NESC 261A1c) (Guyed Poles)

Extreme Wind applied on pole in any direction.

5.1.10 Stringing loads on Dead-Ends

Everyday loads on one side only (0 mph wind, 0 inch ice, 60F (15C), Initial.

Appendix 2: High Voltage Overhead Transmission

5.1.11 PLS Wind Direction for Structure Loading

Designers shall conservatively use wind applied normal to all spans simultaneously when selecting structures for new designs.

5.2 Load Cases – Clearance Verification

The following clearance load cases shall be included to check vertical and horizontal clearances. “Line Design Clearances” are shown in Attachment 2.

Table 5.2.1 – Clearance Load Cases

Description	Wind Loading	Ice Loading	Temp.	NESC Ref.	Condition	Clearance Check
Max. Temp. (ACSR)	0 psf	0 in.	212°F (100°C)	232A	Final	Vertical Clearance
Max. Temp (ACSS & ACCC)	0 psf	0 in.	347°F (175°C)	232A	Final	Vertical Clearance
Max. Temp (ACAR)	0 psf	0 in.	176°F (80°C)	232A	Final	Vertical Clearance
NESC Zone						
Heavy	4 psf	0.5 in.	0°F (-20°C)	230B, Table 230-1, Table 230-2	Final	
Heavy Ice	0 psf	1.0in	32°F (0°C)	232A	Final	Vertical clearance to ground, other conductors, and structures
Medium Wind	6 psf	0 in.	60°F (15°C)	234A2	Initial and Final	Horizontal clearance to ground, other conductors and structures.
High Wind (ROW)	Extreme Wind from Table 5.1.2	0.0 in.	60°F (15°C)		Final	Horizontal Clearance to Edge of Right-of-Way
High Wind (Horizontal Clearance)	100 mph	0.0in.	60°F (15°C)		Final	Insulator swing and Conductor movement (See Section 6.3.3 for more information)
No Wind	0 psf	0.00 in.	60°F (15°C)		Initial and Final	Horizontal clearance to ground, other conductors and structures.

5.3 Load Cases – Wire Stringing

The following load cases shall be used to calculate stringing tensions for conductors and shield wires.

Conductor & Shield Wire Stringing Tensions

0 mph Wind, 0” Ice, 60°F (15°C), Initial & Final Stringing Temperature – 10 to 120°F (-12 to 49°C)

Appendix 2: High Voltage Overhead Transmission

5.4 Load Factor and Strength Reduction

Overload Capacity Factors (**OCF**) shall be coordinated with the appropriate Strength Reduction Factors (**SRF**) and confirm that material strengths are presented as ultimate or working material strengths.

Table 5.4A – NESC & Entergy Design Overload Capacity Factors (OCF)

LOAD CASE	VERT (OCF)	WIND (OCF)	TENSION (OCF)	CODE REF.
Structural Analysis				
NESC Zone Loading (Intact)	1.5	2.5	1.65	253-1
Extreme Wind - (Intact)	1	1	1	
Concurrent Ice & Wind – (Intact)	1	1	1	
Unbalanced – (Intact)	1	1	1	
Single DE NESC Failure Containment	1.5	2.5	1.65	
Single DE Extreme Wind & Heavy Ice	1	1	1	
Cold Case – for Uplift	1	1	1	
Every Day Loads – for Deflection	1	1	1	
Clearance Calculations				
Clearance – Vertical – Heavy Ice (NESC)	1	1	1	232A3
Clearance – Vertical – Max. Temp. (NESC)	1	1	1	232A2
Clearance – Vertical – Static (NESC)	1	1	1	
Clearance – Horizontal Med. Wind – (NESC)	1	1	1	234A2
Clearance – Horizontal R/W – Entergy Max. Wind	1	1	1	

Table 5.4B - Strength Reduction Factors (SRF)

Structure Component	SRF NESC Loads (250B)	SRF Extreme Wind and Ice Loads (250C & 250D)	NESC Code Reference
Steel & Pre-stressed Concrete Structures	1.0	1.0	Rule 261-A, Table 261-1
Foundation & Guy Anchors	1.0	1.0	Rule 261-B, Table 261-1
Guys & Guy Insulator	0.9	0.9	Rule 261-C& 264, Tab. 261-1
Steel Crossarms & Braces	0.9	0.9	Rule 261-D1, Table 261-1
DE Fittings, Splices & Hardware ⁽³⁾	1.0	0.8	Rule 261-H2C
Support Hardware ⁽²⁾	1.0	1.0	Rule 261-D-1, Table 261-1
Insulators – Suspension	0.50	0.65	Table 277-1 ⁽⁴⁾
Insulators – Post	0.50	0.50	Table 277-1 ⁽⁴⁾
Conductor & Shield Wire	(1)	(1)	Rule 261-H1

(1) Conductor and shield wire maximum wire tensions are taken from NESC Code Section 261- H1.

(2) Support hardware includes bolts and plates supporting davit arms, braced post and post insulators, brackets, suspension tees and other miscellaneous supports not supporting conductor or shield wire dead-

Appendix 2: High Voltage Overhead Transmission

ends. The reduction factors shown are multiplied by the ultimate strength of the part as indicated by the manufacturer.

(3) Dead-end fittings include bolts and dead-end tees used to dead-end conductors and shield wires. The manufacturer generally gives the ultimate strength of the tees. This value is then reduced by the reduction factor shown. The “minimum tensile strength” shown for bolts by the Vendor is the allowable tensile load that shall be used on the bolt without the combined load of shear produced in a guyed structure. These loads are not reduced by the reduction factor; however, the shear values given shall be reduced depending on the actual tensile stress, in accordance with the interaction equation.

(4) NESC 2017

6 CLEARANCE AND RIGHT OF WAY REQUIREMENTS

This section covers vertical and horizontal clearance requirements for the Transmission Lines, which include NESC vertical and horizontal clearance requirements from Section 23 of the 2017 Code or counterpart for subsequent codes for HV transmission lines in Entergy’s Service Area plus an added safety buffer, as described below.

6.1 Vertical Clearance – Over Ground

NESC and Entergy vertical clearances over various ground surfaces are shown in Attachment 2. These clearances are based on the 2017 Code, Table 232-1, with the voltage adder defined in Rule 232C1a, using the sags calculated under Rules 232A2 and 232A3.

See Section 125.2 for Clearance Load Cases.

The actual clearance to ground shall be based on the measurement to ground at the low point in the line as determined when the line is at maximum sag. For purposes of determining the required clearance for the Transmission Lines,

NESC Clearance = Table 232-1 Clearance + Voltage Adder (.4"/kV in excess of 22kV)

Entergy-Required Minimum Clearance = NESC Clearance + Safety Buffer

NESC provides consideration for clearances over water surfaces, including floodwater. Footnotes 17-21 to Table 232-1 shall be carefully considered when determining necessary clearances. For flood-prone areas that do not typically have standing surface water and are not subject to USACE or other permits, the normal flood level (10-year flood level) shall be considered along with required clearances for areas not suitable for boating. For most spans over such areas, clearances that consider or are based on vehicle access with un-flooded ground surfaces will continue to apply. Lines leading into generating facilities, EHV interconnections, or other lines where increased reliability is desired shall consider less frequent flood events (e.g., 50-year floods or 100-year floods) to avoid potential service interruptions. Such lines shall be designed to higher flood levels where the incremental costs are justified and will generally be compared to NESC requirements for water surface not suitable for sailboats.

6.2 Other Vertical Clearances

6.2.1 Supply Conductors (69 kV and above)

NESC and Entergy vertical clearances between various electricity supply lines and non-current carrying wires are also shown in Attachment 2. These clearances are based on the 2017 Code, Table 233-1, with the voltage adder defined in Rule 233C2a, using the sags calculated under Rules 233A1a (3)(b) and 233A1a (3)(c).

Appendix 2: High Voltage Overhead Transmission

The design clearance shall be measured as the distance between the field measured existing line and the design maximum sag.

The Entergy-Required Minimum Clearance: NESC Clearance + Safety Buffer

Attachment 2 shows the minimum vertical clearances over various ground surfaces and uses.

The line Designer shall establish “Prohibitive Zones” with the appropriate Design Clearances on the plan profiles within PLS-CADD in the areas where these considerations occur. Considerations could be but not limited to environmental, archaeological, landowner constraints, etc.

6.2.2 Substations

Transmission line vertical clearances inside substations shall meet the vertical clearance requirements shown in Attachment 2.

6.2.3 Miscellaneous

To every extent possible, ROW shall be selected, and ROW agreements written, to preclude structures, signage, and other miscellaneous items from being located beneath the transmission circuits. To the extent such items cannot be so precluded, the vertical clearances for the Transmission Line shall meet the basic NESC clearance requirements for each applicable clearance set forth in Attachment 2, plus an additional 4.5 feet.

6.3 Horizontal Clearance

All horizontal clearances shall include the deflection of the structure and the displacement of the conductor added to the clearance requirements defined below. Clearances per Section 6.3.1 and Section 6.3.2 shall be based on the development of the clearance envelopes shown in the NESC for each situation plus 4.5 feet at a minimum. Basic NESC clearances, including horizontal clearances, are summarized in Attachment 2.

6.3.1 Adjacent Supply Lines

Horizontal clearances to adjacent supply lines shall be calculated using loads described in Section 5.1.2. This clearance is based on an envelope as shown in NESC Figures 233-1, 2&3 and using the following loadings:

The horizontal movement shall be calculated using the medium wind defined under Rule 233A1a(1&2) using (1) a 6 lb/sf wind at 60°F (15°C) and no ice or (2) no wind at 60°F (15°C).

The maximum sag, Rule 233A1a(3), shall be calculated (a) using 120° F (49°C) with no wind; (b) using the max temperature; or (c) the Code Ice thickness with a temperature of 32°F (0°C) and no wind.

PLS-CADD shall be used to define the envelope vertices and check clearance to adjacent supply lines.

6.3.2 Adjacent Buildings and other Structures

The required clearance between conductors and buildings or other structures is covered in Rule 234 and varies between the various structure types. The loadings used for the clearance envelopes are given in Section 5.1.2. The Designer shall use PLS-CADD to check these clearances after specifying the required load cases and clearances.

6.3.3 Insulator/Conductor Swing Clearance

Clearances to the supporting structure resulting from insulator swing are addressed in Section 8.1. Additionally, air gap clearances between adjacent circuits on different structures are to be checked under

Appendix 2: High Voltage Overhead Transmission

the high wind load case in Section 5.1.2. Minimum clearance shall be associated for the higher voltage for the 100-mph swing clearance given in Table 8.1.2.

6.3.4 Right of Way Requirements

6.3.4.1 Rights of Way for New Lines

Rights of way (**ROW**) for new transmission lines must provide spacing sufficient to assure reliability and equipment accessibility for maintenance and construction.

Required ROW widths for new lines must be determined considering four primary parameters: (a) the effective structure width(s), taken as the outboard conductor spacing for the structure; (b) the minimum required spacing between adjacent circuits on separate structures; (c) the conductor displacement due to wind; and (d) a vegetation management width at the edges of the ROW to allow for a cyclical growth and periodic trimming schedules. The sum of the structure widths, any additional circuit spacing dimensions, and the conductor displacements (including the effects of structure deflection, insulator swing, and conductor movement) is called the conductor movement envelope (W_{CME}). Adding the appropriate vegetation management width on each side of W_{CME} gives the minimum allowed ROW width for purchase. Note that total minimum allowed ROW widths for purchase will be rounded upward in whole 5 foot increments (e.g., 161 feet is rounded to 165 feet.) The four parameters described above are illustrated for typical ROW situations in Figure 6.3.4.1-1 and Figure 6.3.4.1-2. Additional figures are found in Attachment 4.

Figure 6.3.4.1-1 – Typical Single Structure ROW

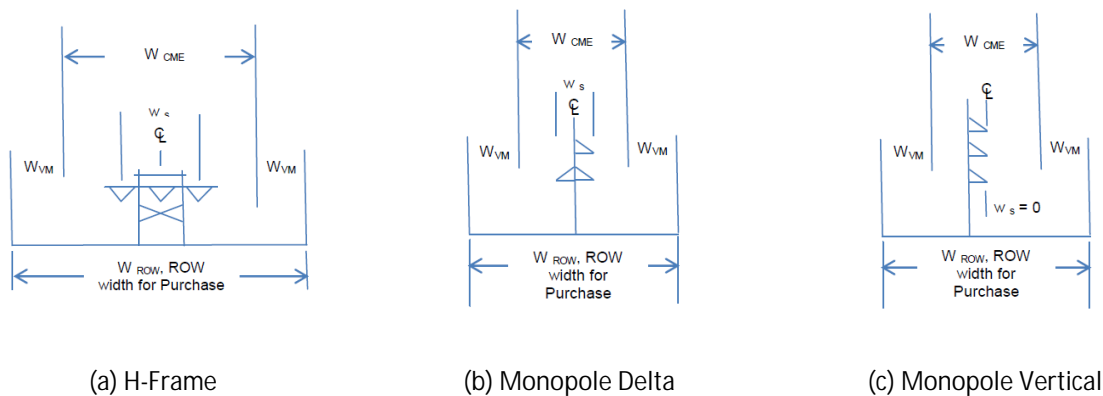

Notes: w_s = Effective Structure Width (Outboard Conductor Spacing) W_{VM} = Vegetation Management Width; W_{CME} = Width, Conductor Movement Envelope; Add Width = c/c Spacing

Appendix 2: High Voltage Overhead Transmission

Figure 6.3.4.1-2 – Typical Double Structure ROW

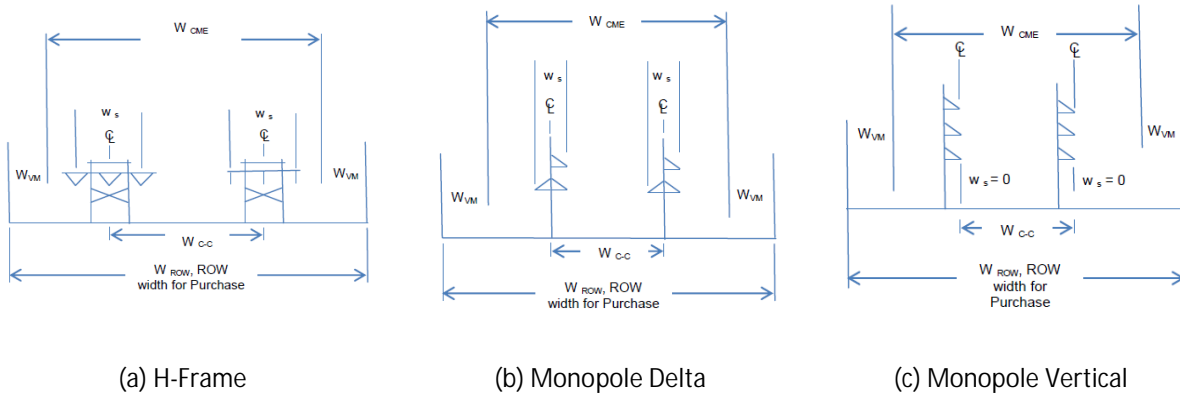

Notes: w_s = Effective Structure Width (Outboard Conductor Spacing) W_{VM} = Vegetation Management Width; W_{CME} = Width, Conductor Movement Envelope W_{C-C} = Center to Center Structure Spacing

6.3.4.2 Effective Structure Width (w_s) or Outboard Conductor Spacing

Except where special circumstances warrant use of larger values, the minimum allowed ROW widths for new construction shall be based on the effective structure widths (w_s) for standard structure framings as set forth in Table 6.3.4.2-1.

Table 6.3.4.2-1 – Typical Effective Structure Widths

Voltage	H-frames (ft.)	Single Pole	
		Delta/ Vert. Double Circuit (ft.)	Single Circuit Vertical (ft.)
500kV	67.66	28.00	0.00
345kV	51.00	24.00	0.00
230kV	40.00	18.00	0.00
161/138/115 kV	32.00	14.33	0.00
69kV	24.00	12.00	0.00

Note that for vertical conductor configurations, the conductors fall on the centerline of the circuit/ROW and the monopole structure itself is offset by a function of the insulator length. In such configurations there are no outboard conductors, and the effective width of the structure is treated as zero.

When determining ROW requirements for constructing a new transmission line adjacent to an existing transmission line (discussed in more detail below), the actual effective widths of the existing structure shall be determined and used in the calculation.

Adjacent Circuit Separation (W_{c-c})

Circuit center to center horizontal spacing for ROW determinations shall be as shown in Table 6.3.4.2-2 unless the Performance Standard requires use of a higher value.

Solar BOT Scope Book: Appendix 2 High Voltage Overhead Transmission

Appendix 2: High Voltage Overhead Transmission

Table 6.3.4.2-2 – Minimum Spacing for Adjacent Circuits (W_{c-c})

Voltage	H-frames (ft.)	Single Pole	
		Delta/ Vert. Double Circuit (ft.)	Single Circuit Vertical (ft.)
500kV	140	96	70
345kV	120	65	45
230kV	75	50	35
161/138/115 kV	60	40	30
69kV	45	30	20

For 345 kV and 500 kV Transmission Lines, the distances specified for adjacent single pole circuits reflect geometrical limits only. Electrical effects (audible noise, EMF, etc.) must be studied, and will require additional separation if indicated by the study. For two adjacent circuits of different voltage or framing, the larger of the two required separation distances shall be used.

6.3.4.3 Displaced Conductor Position (WCD)

During detailed line design, the displaced conductor positions are calculated including the effects of structure deflection and insulator/hardware swing; and using the load cases contained in Section 5. Wind loads are applied transversely in each direction to displace the conductor away from the centerline as illustrated below.

Figure 6.3.4.3-1 – Displaced Conductor Position & Relationship to W_{CME} and w_s

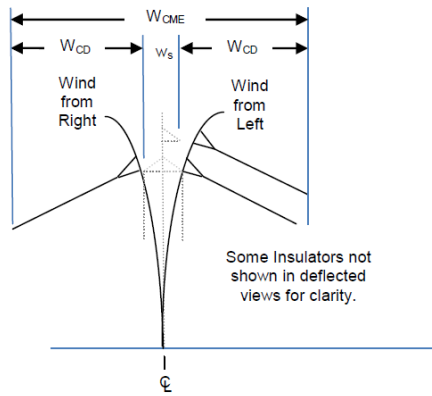

Notes: w_s = Effective Structure Width (Outboard Conductor Spacing) W_{CME} = Width, Conductor Movement Envelope; W_{CD} = Displaced Conductor Position Including Structure Deflection

In addition to checking required horizontal clearances per Sections 6.3.1 and 6.3.2, the displaced conductor position shall stay within the available conductor movement envelope under the extreme wind cases described in Table 5.1.2. As part of the line design, pole placements and span lengths must be adjusted if required to maintain required clearances and keep the conductor within the available width.

Appendix 2: High Voltage Overhead Transmission

The available CME widths in Table 6.3.4.4-1 and Table 6.3.4.5-1 contemplate and accommodate standard framings, typical spans, the current list of typical conductors and their specified stringing limits, etc. Markedly atypical designs may require a more rigorous evaluation of the ROW requirements. Conversely, severe ROW restrictions will likely require atypical design such as shortened spans.

Note that all tabulated values consider the use of V-string assemblies, braced-post assemblies, suspension units with struts, or other configurations where insulator swing is confined.

6.3.4.4 Vegetation Management Width (WVM)

It is assumed that trees grow or someday will grow at the edge of the ROW, and that normal growth cycles will result in further encroachment into the Vegetation Management Width. Therefore, the conductor movement envelope (**CME**) alone is insufficient as a ROW. Vegetation management in the area adjacent to ROW edges is required to prevent grow-in and to comply with the Minimum Vegetation Clearance Distance (**MVCD** see also definitions). Thus, additional width between the ROW edge and the outboard conductors is essential to allow planned, efficient vegetation management without violating the MVCD.

To accomplish this, apply a Minimum Vegetation Action Threshold Distance (**MVATD**) for prioritizing corrective maintenance. The Vegetation Management Width (W_{VM}) to be used when determining ROW width shall bound the MVATD and MVCD, and is tabulated below (values for MVATD and MVCD are provided for reference):

Table 6.3.4.4-1 – Vegetation Management Widths

Voltage	WVM (ft.)	MVATD (ft.)	MVCD (ft.)
500kV	22.5	14.68	7.4
345kV	15.0	9.44	4.5
230kV	12.5	5.14	4.3
161/138/115 kV	10	3.42 / 2.94 / 2.45	2.9 / 2.4 / 2.0
69kV	7.5	2.45	1.2

Where a circuit is to be built at a given voltage but operated at a lower voltage, the W_{VM} for the higher voltage shall be used to determine ROW width.

6.3.4.5 Calculation of Minimum Allowed ROW Width for Purchase - New Single Circuit Line or Double Circuit on the Same Structures

As illustrated in the preceding figures, at any given point, the minimum allowed ROW shall equal the applicable CME plus the applicable vegetation management width (W_{VM}) on each side of the ROW. Assuming multiple circuits are the same voltage, standard ROW widths are determined as:

$$ROW = WCME + 2(WVM), \quad \text{rounded up to the next whole 5' increment}$$

and are tabulated by voltage and framing type in Table 6.3.4.5-1 and Table 6.3.4.5-2.

Appendix 2: High Voltage Overhead Transmission

**Table 6.3.4.5-1 – Minimum Required ROW Widths for Single Structures
(Single Circuit or Multi-Circuit on Same Structure)**

		Typical ROW Width (ft.) for Purchase			Conductor Movement Envelope - CME (ft.)		
Line Voltage (kV)	WVM (ft.)	H-Frame	Single Pole Delta/Vertical Double Circuit	Single Pole Vertical	H-Frame	Single Pole Delta/Vertical Double Circuit	Single Pole Vertical
500	22.50	225	125	125	180	80	80
345	15.00	190	155	135	160	125	105
230	12.50	150	125	110	125	100	85
161	10.00	120	100	90	100	80	70
69	7.50	90	75	65	75	60	50

Table 6.3.4.5-2 – Minimum Allowed ROW Widths for Multiple Structures and Circuits

ROW Widths (ft.) assuming two identical lines									
Line Voltage (kV)	ROW Width for Purchase (ft.)			Conductor Movement Envelope - CME (ft.)			Add. Width per line (ft.)		
	H-Frame	Single Pole Delta/Vertical Double Circuit	Single Pole Vertical	H-Frame	Single Pole Delta/Vertical Double Circuit	Single Pole Vertical	H-Frame	Single Pole Delta/Vertical Double Circuit	Single Pole Vertical
500	365	225	195	320	180	150	140	96	70
345	310	220	180	280	190	150	120	65	45
230	225	175	145	200	150	120	75	50	35
161	180	140	120	160	120	100	60	40	30
69	135	105	85	120	90	70	45	30	20

Notes regarding Tables 6.3.4.5-1 and 6.3.4.5-2:

1. Tabulated 500 kV single pole ROW reflect an atypical short span design intended to compact lines on narrower ROWs.
2. As noted in 6.3.4.1, tabulated values reflect Vee-String, Brace Post, Suspension/Strut or other insulator assemblies where conductor attachments are somewhat restrained. Where suspension I-String assemblies are used: at 230 kV and below the ROW widths given shall be increased by 5 feet; and at 345 kV they shall be increased by 10 feet. Only Vee-String assemblies are currently approved for 500 kV.

Appendix 2: High Voltage Overhead Transmission

3. The ROW values presented are indicative of what would be required in straight sections of ROW containing tangent or light angle structures. Large angle changes using multi-pole structures or extensive guying patterns will require additional ROW in the vicinity of the angle structure.

7 CONDUCTOR AND SHIELD WIRE INFORMATION

This section includes design information about standard conductors, both in single and in bundled configurations, along with standard shield wires, including fiber optic wires. It includes tension and vibration control data for the NESC and Entergy design conditions. Conductors and shield wires shall be selected from these standards unless Buyer and Seller otherwise agree in a writing signed by authorized representatives of the Parties.

7.1 Entergy Standard Conductors

The required technical standards for conductors are set forth in this Section 7.1_(properties based on Southwire® data unless noted.):

Table 7.1A – Standard Conductors – Mechanical Properties

Type	Size	Stranding	Code Word	Area (in ²)	Dia. (in.)	Weight (lb/ft)	Strength (lbs)
ACCC/TW ⁽⁵⁾	1949	56/1	LAPWING ⁽⁴⁾	1.647	1.504	1.938	48,900
	1582	33/1	BITTERN ⁽⁴⁾	1.336	1.345	1.566	39,400
	1428.5	33/1	BEAUMONT ⁽⁴⁾	1.232	1.294	1.436	43,700
	1222	33/1	CARDINAL ⁽⁴⁾	1.053	1.198	1.224	37,100
	821.2	18-1	GROSBEAK ⁽⁴⁾	0.725	0.990	0.836	30,400
ACSS	1590	45/7	LAPWING	1.34	1.50	1.79	27,900
	1272	45/7	BITTERN	1.07	1.35	1.43	22,300
	954	54/7	CARDINAL	0.85	1.20	1.23	26,000
	666.6	24/7	FLAMINGO	0.59	1.00	0.86	18,200
ACSR	1780	84/19	CHUKAR	1.51	1.60	2.08	51,000
	1590	45/7	LAPWING	1.34	1.50	1.79	42,200
	1272	45/7	BITTERN	1.07	1.35	1.43	34,100
	1033.5	45/7	ORTOLAN ⁽¹⁾	0.87	1.21	1.163	27,700
	954	54/7	CARDINAL	0.85	1.20	1.23	33,800
	954	45/7	RAIL ⁽²⁾	0.80	1.165	1.075	25,290
	666.6	24/7	FLAMINGO	0.59	1.00	0.86	23,700
	336.4	26/7	LINNET	0.31	0.72	0.46	14,100
AC AR	1024.5	34/13	N/A ⁽³⁾	0.80	1.165	0.96	23,100

Appendix 2: High Voltage Overhead Transmission

Type	Size	Stranding	Code Word	Area (in ²)	Dia. (in.)	Weight (lb/ft)	Strength (lbs)
	649.5	18/19	N/A	0.51	0.93	0.61	17,100
	395.2	15/7	N/A	0.31	0.72	0.37	10,100

(1) Not for New Construction, Capital Maintenance only

(2) 345 kV and 500 kV only – Use for new construction

(3) 500 kV only – for Capital Maintenance work only

(4) Source: General Cable/LAMIFIL Data

(5) It is generally preferential to develop a custom conductor solution using an ACCR conductor in lieu of the ACCC conductors. Use of the ACCC standards will generally be limited to extension of existing ACCC lines or other similar circumstances.

Ampacity ratings for the standard conductors are determined using the commercially available software SWRate, which is based on the methodology of IEEE 738. Ampacity was determined using design parameters specified in Entergy standards and the conductor properties contained in the SWRate program library. Line ratings are also expressed as conductance in MVA using the expression $MVA = V * A * 0.001 * 3^{0.5}$, where V is voltage in kV, and A is rated ampacity in amps. Ampacity and conductance ratings for the standard conductors are summarized below.

Appendix 2: High Voltage Overhead Transmission

Table 7.1B – Standard Conductors – Capacity

Type	Size / Code Word	Rated Amps ⁽¹⁾	MVA 69kV	MVA 115kV	MVA 138kV	MVA 161kV	MVA 230kV	MVA 345kV	MVA 500kV
ACCC/TW ⁽³⁾	1949 / LAPWING	2490	298	496	595	694	992	-	-
	1582 / BITTERN	2180	261	434	521	608	868	-	-
	1429 / BEAUMONT	2050	245	408	490	572	817	-	-
	1222 / CARDINAL	1857	222	370	444	518	740	-	-
	821.4 / GROSBEAK	1439	172	287	344	401	573	-	-
ACSS	1590 / LAPWING	2263	270	451	541	631	902	-	-
	1272 / BITTERN	1957	234	390	468	546	780	-	-
	954 / CARDINAL	1607	192	320	384	448	640	-	-
	666.6 / FLAMINGO	1312	157	261	314	366	523	-	-
ACSR	1780 / CHUKAR	1608	192	320	384	448	641	-	-
	1590 / LAPWING	1494	179	298	357	417	595	-	-
	1272 / BITTERN	1303	156	260	311	363	519	-	-
	1033.5/ ORTOLAN ⁽²⁾	1144	137	228	273	319	456	-	-
	954 / CARDINAL	1088	130	217	260	303	433	-	-
	954 / RAIL	1088	130	217	260	303	433	650	942
	666.6 / FLAMINGO	882	105	176	211	246	351	-	-
	336.4 LINNET	575	69	115	137	160	229	-	-
ACAR	ACAR 1024.5 ⁽²⁾	878	105	175	210	245	350	-	760
	ACAR 649.5	658	79	131	157	183	626	-	-
	ACAR 395.2	483	58	96	115	135	192	-	-

(1) At normal operating temperatures, 212°F (100°C) for ACSR, 347°F (175°C) for ACSS and ACCC, and 176°F (80°C) for ACAR.

(2) Other historical limits may govern.

(3) It is generally preferential to develop a custom conductor solution using an ACCR conductor in lieu of the ACCC conductors. Use of the ACCC standards will generally be limited to extension of existing ACCC lines or other similar circumstances.

7.2 Standard Shield Wires

The required technical standards for shield wires are set forth in Table 7.2 below:

Table 7.2 – Standard Shield Wires

Code Word	Class Type	Size	Strand-Ing	Area (in ²)	Dia. (in.)	Weight (lb/ft)	Strength (lbs)
7 #7	Alumoweld	0.0	7	0.11	0.43	0.33	19,060

Appendix 2: High Voltage Overhead Transmission

7.3 Standard Optical Ground Wires

The required technical standards for optical ground wires (OPGW) are set forth below:

Table 7.3 – Standard OPGW Wires

<u>Code Word</u>	<u>Class Type</u>	<u>Fibers</u>	<u>Strand-Ing</u>	<u>Area (in²)</u>	<u>Dia. (in.)</u>	<u>Weight (lb/ft)</u>	<u>Strength (lbs)</u>
DNO-5651	AlumaCore	24LT	13	0.151	0.528	0.36	18,391
DNO-6651	AlumaCore	48LT	9/6	0.221	0.646	0.42	18,053
DNO-3476	AlumaCore	24	13	0.151	0.528	0.36	18,433
DNO-4596	AlumaCore	48	9/6	0.221	0.646	0.42	18,053
DNO-6205	CentraCore	24	10	0.166	0.528	0.41	21,845
DNO-6210	CentraCore	48	10	0.166	0.528	0.41	21,845
DNO-8161 ⁽¹⁾	AlumaCore	48	13	0.151	0.528	0.36	18,391
DNO-9800 ⁽²⁾	AlumaCore	48	13	0.151	0.528	0.36	19,391

(1) DNO-8161, 48 fiber AlumaCore will be the default OPGW selection unless project specifics warrant a different selection.

(2) DNO-9800, 48 fiber AlumaCore will be the default OPGW selection for “backbone” applications where dispersion shifted fibers are required by the telecommunications department.

Alternative optical ground wires may be used, provided they meet the same specifications as the above-referenced wires. Similar hardware to that used for standard wires specified herein must be used so that nonstandard hardware does not have to be stocked for maintenance.

7.4 Bundled Conductors

7.4.1 Bundled Conductors (New Construction, excluding 500 kV)

The standard bundled configuration is a vertical bundle in which no spacers are required. If other configurations are used, the conductor supplier and/or manufacture of the spacers shall be consulted regarding spacers requirements.

The standard assembly for bundled dead-end structures shall be the “DEPY” dead-end assembly with a two-insulator attachment to the structure.

Bundled dead-end structures where the maximum tension (with OCF) in each sub-conductor is less than 9700 lbs. may use the “DEP- 2 wire” dead-end assemblies with a single insulator. This assembly shall mainly be used in reduced tension situations.

All bundled structures with angles less than 30 degrees shall be designed as running angle structures, including Structure Types “C”, “F” and “G”. Those with angles greater than 30 degrees shall be designed as dead-end structures.

Appendix 2: High Voltage Overhead Transmission

7.4.2 Bundled Conductors (500 kV)

The standard 500 kV bundled conductor is a triple delta configuration with spacers at approximately 250 foot intervals.

7.5 Sag and Tension Limitations

7.5.1 NESC Tension Limits

Following are the maximum tension limits allowed in the determination of project sag and tension values. The “Zone Loading” tension limit is an NESC requirement for all load cases with an overload capacity factor of 1.65. The tension limits for extreme wind and heavy ice are Entergy requirements and have an overload capacity factor of 1.0. Load cases are shown in Section 5.4. The limit is a percent of the Ultimate Breaking Strength (UBS) of the wire. Limits are based on the Initial tension of the wire.

<u>Load</u>	<u>Tension Limits</u>
• Zone loading (OCF=1.65)	60% UBS - @ Initial Ten. (NESC 261H1)
• Extreme Wind (OCF=1.0)	75% UBS - @ Initial Ten.
• Concurrent Ice & Wind (OCF=1.0)	5% UBS - @ Initial Ten.

Additionally, the NESC (Section 261 H1) requires that the tension at each of the applicable NESC Zone temperatures shown in Table 5.1.2, without external load, shall not exceed the following percent of their UBS:

Initial unloaded tension 35% UBS

Final unloaded tension 25% UBS

These tension limits apply at each of the applicable NESC Zone temperatures shown in Table 5.1.2, unless dampers are used, in which case this limitation is at a maximum of 60°F (15°C).

7.5.2 Tension Limits for Vibration Control

Except for ACCC and ACCR conductors, for vibration control, maximum catenaries (horizontal tension/weight), or “C” values, will be calculated at 0°F (-20°C), 0 mph wind, and 0 inches ice. Calculated values for “C final” shall be 4710 and for “C initial” shall be 6000. Lesser values of “C” will require approval by Buyer.

For ACCC conductors, vibration dampers shall be placed in accordance with the manufacturer’s recommendations.

The following table, “Vibration Control Values”, provides Entergy’s tension limits for the standard conductors. The table was developed considering 900 ft. ruling spans. However, these values may be used for other ruling spans with only slight variations. Other ruling spans will require approval by Buyer.

Table 7.5.2 – Vibration Control Values

<u>Type</u>	<u>Conductor Name</u>	<u>Load Case</u>	<u>Max Tension (pounds)</u>	<u>% of Ultimate Strength</u>
ACSS	LAPWING	0-0-0 (I)	10740	38.5
	LAPWING	0-0-0 (F)	8431	30.2

Appendix 2: High Voltage Overhead Transmission

Type	Conductor Name	Load Case	Max Tension (pounds)	% of Ultimate Strength
	BITTERN	0-0-0 (I)	8580	38.5
	BITTERN	0-0-0 (F)	6735	30.2
	CARDINAL	0-0-0 (I)	7380	28.4
	CARDINAL	0-0-0 (F)	5793	22.3
	FLAMINGO	0-0-0 (I)	5160	28.4
	FLAMINGO	0-0-0 (F)	4051	22.3
ACSR	CHUKAR	0-0-0 (I)	12480	24.5
	CHUKAR	0-0-0 (F)	9796	19.2
	LAPWING	0-0-0 (I)	10740	25.5
	LAPWING	0-0-0 (F)	8431	20.0
	BITTERN	0-0-0 (I)	8580	25.2
	BITTERN	0-0-0 (F)	6735	19.8
	ORTOLAN	0-0-0 (I)	6978	25.2
	ORTOLAN	0-0-0 (F)	5478	19.8
	CARDINAL	0-0-0 (I)	7380	21.8
	CARDINAL	0-0-0 (F)	5793	17.1
	RAIL	0-0-0 (I)	6450	24.9
	RAIL	0-0-0 (F)	5063	19.5
	FLAMINGO	0-0-0 (I)	5160	21.8
	FLAMINGO	0-0-0 (F)	4051	17.1
LINNET	0-0-0 (I)	2760	19.6	
LINNET	0-0-0 (F)	2167	15.4	
ACAR	649.5 ACAR	0-0-0 (I)	3660	21.4
	649.5 ACAR	0-0-0 (F)	2873	16.8
	395.2 ACAR	0-0-0 (I)	2220	22.0
	395.2 ACAR	0-0-0 (F)	1743	17.3
	1024.5 ACAR	0-0-0 (I)	5760	24.9
	1024.5 ACAR	0-0-0 (F)	4522	19.6
SW	7#7 AW	0-0-0 (I)	1980	10.4
	7#7 AW	0-0-0 (F)	1554	8.2
	7/16" Steel	0-0-0 (I)	2400	11.5
	7/16" Steel	0-0-0 (F)	1884	9.1
OPGW	* AlumaCore, DNO-8161	0-0-0 (I)	2160	11.7
	* AlumaCore, DNO-8161	0-0-0 (F)	1696	9.2
	* AlumaCore, DNO-9800	0-0-0 (I)	2160	11.1
	* AlumaCore, DNO-9800	0-0-0 (F)	1696	8.7
ADSS	ADSS-AE024HG611CA2	0-0-0 (I)	546	18.2

Appendix 2: High Voltage Overhead Transmission

Type	Conductor Name	Load Case	Max Tension (pounds)	% of Ultimate Strength
	ADSS-AE024HG611CA2	0-0-0 (F)	429	14.3

*AlumaCore, DNO-8161 is the default.
 Note ADSS is not a transmission standard transmission conductor but is frequently used as an under-built non-transmission conductor. Typical ADSS span is on the order of 200 feet.
 Also note that (F) load cases shall be controlled by both Creep RS and Load RS, and that bimetallic conductors shall consider the effects of compression at high temperatures

7.5.3 Vibration Control for Long Spans Exceeding the Ruling Span

For span lengths greater than the ruling span, the Designer shall take special care to compare the conductor and shield wire sags, to ensure that adequate clearances at mid-span are maintained under all conditions. The shield wire tension shall not exceed 16% of its ultimate strength at 60°F (15°C), final. To account for unusual circumstances (e.g., ravine crossings), it may be necessary to dead-end the shield wire to account for tension differentials and/or increase the tensions along with adding dampers per manufacturer's specifications.

7.6 Correction to Sag when Final Installation is Interrupted

Prolonged stringing durations can affect final sags due to creep beyond that considered in the sagging algorithm. Conductors and shield wires shall be clipped in within 72 hours of achieving the intended stringing tension. Where stringing operations are interrupted or extend beyond this 72-hour threshold, engineering evaluation/approval is required with final approval by Buyer, and the cable manufacturer shall be contacted to obtain technical instructions on the issue.

7.7 Galloping

Certain areas within the Entergy Service Area have been identified as areas prone to galloping and shall require the installation of vibration control devices. These areas are generally in north Arkansas along the Mississippi River in open, flat areas where it is possible for ice to form on the cables.

Phase spacing shall be set to avoid mid-span interference between phases through the required assumption that double ellipse galloping will occur on any span exceeding 400 feet. A galloping overlap of less than 10 percent between phases will be allowed in the design process. It is generally assumed that using span lengths between 400 and 900 feet would eliminate this overlap. The ruling span is set at 80% of the limiting span for this analysis.

7.8 Aeolian Vibration

Aeolian vibration fatigue damage typically occurs in flat, open areas. The most effective way to reduce this type of vibration is to reduce the line tension. Also, the installation of dampers may eliminate or reduce this vibration; however, the conductor and damper suppliers shall be consulted regarding these conditions.

The use of ACSS type conductors may also reduce this vibration after one year of operation because of the self-damping characteristics built into this type of conductor.

7.9 Conductor Corona

Two solutions to reduce conductor corona are larger conductors and/or bundled conductors.

For 161 kV, 115 kV, and 69 kV, 336 kcmil ACSR "Linnet" shall be the minimum conductor size.

Appendix 2: High Voltage Overhead Transmission

At 230 kV, bundled 395 kcmil ACAR conductors or, for single conductor lines, a recommended standard wire size of 954 kcmil ACSR. The minimum wire size for 230 kV using industry standards is approximately one inch in diameter. The smallest standard wire size that meets the industry standard minimum wire size is “Flamingo” 666.6 kcmil ACSR.

For 500 kV transmission lines, 1024 kcmil ACAR and 954 kcmil ACSR “Rail” shall be the minimum conductor sizes to avoid corona effects. The standard for new construction is 954 kcmil “Rail”.

The selection of conductor size, considering corona losses, shall be estimated using the attached figure (obtained from the Westinghouse Transmission and Distribution Manual) entitled “Fig. 31 - Quick Estimating Corona-Loss Curves”. This figure is attached as Attachment **3**.

7.10 ACSS and ACSS/TW Conductor

7.10.1 ACSS Sags – Tensions - Stringing

ACSS suppliers have recommended that the ACSS & ACSS/TW conductors be pre-tensioned for approximately 10 to 15 minutes before final sagging of the line. This procedure inelastically stretches and elongates the aluminum wires and the steel core provides total support of the conductor in normal operation. Since little or no stress is left in the aluminum wires, initial and final sags and tensions are nearly the same. Pre-stressing is a means of reducing creep and enhancing self-damping capability. Recommendations for pre-stressing vary and range from the maximum tension. Consult with cable manufacturer for prestressing methodology and specifications.

7.11 Fiber Optic/Shield Wire Requirements

Fiber Optic Shield Wire (*OPGW*) is often the preferred shield wire. For structures with two shield wires, one shield wire will typically be OPGW and one shield wire will typically be 7#7. Project specific shield wire requirements is subject to approval by Buyer. Substation Relay Design, SCADA, Substation Networking and Corporate Telecommunications will need to determine the number of fibers that they will need. Standard Entergy shield wires are found in Section 7.

7.11.1 Fiber Optic Details

The fiber optic line may be dead-ended if the line angle is over 30°. For line angles between 30° and 50°, a heavy angle suspension assembly may be utilized. Fiber optic construction details are shown on the standard assembly drawings, shown in Attachment 1.

7.11.2 Splice Box Locations

Splice boxes shall be placed at existing or expected future laterals and substations. Additional boxes will be needed at intervals along the line, generally corresponding to reel wire length, line angles, and considering the nearest points of access.

7.12 SW Sagging Relative to Conductors

Every effort shall be made to ensure that the shield wire(s) have less sag than the conductor, so that any flashovers are encouraged to occur at a structure rather than at mid-span. It is suggested that the shield wire have a lesser amount of sag by approximately 0.33 percent of the span length, or approximately two (2) feet, under normal stringing loads, i.e., 60°F (15°C). Where this is not feasible, the tension limits to control vibration in Table 7.5.2 may be relaxed to pull the shield wire more tightly and achieve greater separation. Where the tension limits of Table 7.5.2 are relaxed, a conductor vibration study shall be performed, and vibration dampers shall be installed on the shield wire per the recommendations of the

Appendix 2: High Voltage Overhead Transmission

vibration study. Alternately, the standard framing may be modified with approval from Buyer to provide greater separation between the shield wire and the conductor.

7.13 Conductor and Shield Wire Marking

7.13.1 Aerial Patrol Marking

Aerial patrol marking to provide early warning of the hazards due to crossing transmission lines shall be applied as described herein.

7.13.2 Marking for Federal Aviation Administration (FAA) regulations

Marking required to comply with Federal Aviation Administration (FAA) regulations shall not be confused with the aerial patrol marking described in paragraph 7.13.1. When routing new lines, it is generally better to avoid selecting routes that pass within close proximity of airports, landing strips, heliports and facilities such as hospitals that might have aircraft landing on improvised landing sites. Such facilities can be generally identified by examining aerial navigation maps available at pilot centers in most public airports, examination of quadrangle maps published by the U.S. Geological Commission, examination of aerial photographs acquired for the line project, and other sources. Where these facilities cannot be avoided and where it is determined that FAA rules apply, the requirements of FAA Advisory Circular AC 70/7460-1K shall apply.

7.13.3 Navigable Waterway Marking

Lines crossing navigable waterways shall be marked as delineated in the applicable permits.

7.13.4 Avian

Avian markers are to be installed where appropriate to make the line more visible to birds. Several forms of markers are commercially available and marketed to increase line visibility and reduce the possibility of avian mortality. Avian markers shall be required only where specified by wildlife agencies or by applicable permits.

7.13.5 Slow-Moving Vehicle Signs

Slow-moving vehicle signs shall be placed on the third and fourth adjacent structures on both sides of any crossover lines, with the signs facing the approach to the lines from either side of the crossover. It is very important that all crossings be marked on the same number of advance structures for safety reasons. One sign on each structure shall be used to indicate a single crossover ahead. If two crossovers in close proximity exist ahead, then two signs shall be installed on each structure, one sign over the other, if possible. Two-crossover situations shall also have single signs on both sides of structures between the crossovers. Details of the installation are covered in an attachment to this Appendix, but generally the signs shall be near the top of the poles or towers of the structures. When used on wooden poles, the signs shall be outside any woodpecker wire covering the pole.

7.13.6 Spiral Vibration Dampers (Yellow)

Spiral dampers in addition to slow-moving vehicle signs may be desirable in some cases with extraordinary visibility difficulty. When used, such dampers shall be installed with a minimum of one pair of dampers on both sides of centerline of the line being patrolled at a point just outside the conductor locations but not less than 15 feet between the pairs. If there are two shield wires on the crossover line, half of the dampers shall be installed on each shield wire.

Appendix 2: High Voltage Overhead Transmission

7.13.7 QuikMark Devices

QuikMark devices, in addition to slow-moving vehicle signs, may be desirable in some cases with extraordinary visibility difficulty. When used, QuikMark devices shall be installed with a minimum of three QuikMark devices on each side of centerline of the line being patrolled at a point just outside the conductor locations but not less than 15 feet between each trio. If there are two shield wires on the crossover line, install half of the QuikMarks on each shield wire.

7.13.8 QuikMark Devices Combined with Spiral Vibration Dampers

QuikMark devices and spiral dampers may be combined to mark shield wires by keeping equal numbers of each on each side of the line being patrolled so the visual effects are balanced on the line. When the Transmission Line crosses under the line of another, the minimum requirement is for QuikMark devices or spiral dampers or both to be installed on the shield wires of the other line. This is for the safety of Entergy aerial patrollers and to protect Entergy and others from claims by the owner of the other line for property damage, lost revenues on the other line, and other claims.

8 OTHER ELECTRICAL CRITERIA

8.1 Electrical Insulation

All insulators shall be polymer (non-ceramic). Insulators that are procured from one of Entergy's approved vendors for insulators and adhere to Entergy's standards are assumed to meet this specification. Insulator types include dead-end, braced post, post, suspension and jumpers. All new HV (69 kV and above) Transmission Lines shall have insulators with corona rings installed. Details for these insulators are included in Attachment 1.

8.1.1 Insulator Swing

8.1.1.1 Mechanical Clearance

Post and braced post assemblies have the potential for contact between their suspension shoe and their post insulator. The suspension shoe may swing towards the supporting post insulator without any wind due to line deflection angle and/or phase position changes between consecutive structures. With a 6 PSF wind (60 degrees Fahrenheit and final wire tension) further displacing the conductor hardware from its everyday displacement, contact with the sheds (or corona ring) is not allowed. With extreme wind specified in Table 5.1.2 of the design criteria (60 degrees Fahrenheit and final wire tension) further displacing the conductor hardware from its everyday displacement, contact with the rod's sheath is not allowed. A swing angle adapter shall be used to increase mechanical clearance. This adapter does not preclude mechanical conflict, so conductor position shall still be checked.

8.1.1.2 Electrical Clearance

Table 8.1.1.2 specifies required certain clearances from the energized conductor shoe to non-energized portions of the structure under the prescribed conditions specified in the footnotes. These clearances were built into Entergy's standard framings shown in Attachment 1. Certain atypical conditions, such as short spans, structures in dips, transition between framings or phasing, deflection angles near the top of the range, and higher tensions, can warrant deviations from standard, such conditions will require Seller to acquire approval from Buyer. Conductor position shall be verified against Table 8.1.1.2 that the required minimum clearances are met, especially for suspension insulators. For posts and braced posts, the standard post lengths will ensure that these clearances are met, except for the no-wind clearance for

Solar BOT Scope Book: Appendix 2 High Voltage Overhead Transmission

Appendix 2: High Voltage Overhead Transmission

bundled conductors. For bundled posts and bundled braced posts, the conductor hardware shall not be allowed to swing more than 30 degrees toward the pole without wind (0 degrees F, initial). Note that the swing angle adapters mentioned in Section 8.1.1 do not improve electrical clearance.

Table 8.1.1.2 – Minimum Insulator Swing Clearances

FRAMING VOLTAGE	CONDITION	CLEARANCE TO ARM OR STRUCTURE	CLEARANCE TO GUY
500 kV	6 psf wind ⁽¹⁾	123 in	11 ft.
500 kV	100 mph ⁽²⁾	60 in	5 ft.
500 kV	no wind ⁽³⁾	140 in	12 ft.
500 kV	no wind ⁽⁴⁾	140 in	12 ft.
345 kV	6 psf wind ⁽¹⁾	85 in	8 ft.
345 kV	100 mph ⁽²⁾	41 in	4 ft.
345 kV	no wind ⁽³⁾	105 in	9 ft.
345 kV	no wind ⁽⁴⁾	105 in	9 ft.
230 kV	6 psf wind ⁽¹⁾	52 in	6 ft.
230 kV	100 mph ⁽²⁾	27 in	3 ft.
230 kV	no wind ⁽³⁾	83 in	8 ft.
230 kV	no wind ⁽⁴⁾	88 in	8 ft.
161 kV	6 psf wind ⁽¹⁾	37 in	5 ft.
161 kV	100 mph ⁽²⁾	19 in	2 ft.
161 kV	no wind ⁽³⁾	60 in	7 ft.
161 kV	no wind ⁽⁴⁾	71 in	7 ft.
138 kV	6 psf wind ⁽¹⁾	34 in	5 ft.
138 kV	100 mph ⁽²⁾	16 in	2 ft.
138 kV	no wind ⁽³⁾	54 in	7 ft.
138 kV	no wind ⁽⁴⁾	65 in	7 ft.
115 kV	6 psf wind ⁽¹⁾	28 in	5 ft.
115 kV	100 mph ⁽²⁾	13 in	2 ft.
115 kV	no wind ⁽³⁾	49 in	7 ft.
115 kV	no wind ⁽⁴⁾	60 in	7 ft.
69 kV	6 psf wind ⁽¹⁾	17 in	3 ft.
69 kV	100 mph ⁽²⁾	8 in	1 ft.
69 kV	no wind ⁽³⁾	49 in (36 in) ⁽⁵⁾	6 ft.
69 kV	no wind ⁽⁴⁾	60 in (49 in) ⁽⁵⁾	6 ft.

(1) Max required value between switch surge and NESC air gap. Controlled by NESC with 10% Voltage Surge (1.1 x nom. Voltage).

(2) 60 Hz minimum flash over distance.

(3) No wind clearance for suspension insulator (Impulse Air Gap).

(4) No wind clearance for running angles (Impulse Air Gap).

Appendix 2: High Voltage Overhead Transmission

(5) 69 kV framings use 115 kV no-wind air gaps for improved lightning performance. On existing structures where there isn't room for longer insulators and air gaps, the numbers in parentheses apply.

8.1.1.3 Typical Standard Davit Arms

For the purpose of determining clearances presented in Table 8.1.1.2 accounting for insulator swing; as well as for the purpose of evaluating shield angle and determining conductor coordinates, the following arm lengths and insulator lengths shall be used:

Table 8.1.1.3 – Typical Davit Arm and Insulator Lengths for New Construction

INSULATOR LENGTH⁽²⁾			
VOLTAGE (kV)	TYPE	INSULATOR LENGTH (IN)	DESIGN LENGTH (IN.)
69	SUS	59	66
161	SUS	73	78
230	SUS	89	96
69	DE/RA	62	80
161	DE/RA	92	98
230	DE/RA	104	110
69	LP/BP	60	60
161	LP/BP	76	78
230	LP/BP	94	94
DAVIT ARM LENGTH⁽¹⁾			
VOLTAGE (kV)	TYPE	LENGTH	RISE (IN.)
69	Tangent	5'-6"	13
161	Tangent	8'-6"	25
230	Tangent	11'-0"	24
69	Swing	3'-0"	N/A
161	Swing	4'-0"	N/A
230	Swing	5'-0"	N/A
69	DE	5'-0"	12
161	DE	6'-0"	15
230	DE	8'-0"	20

(1) Davit Arm Length is from pole face to conductor attachment

(2) Design length includes hardware.

8.1.1.4 Insulator Attachments – 69 kV, 161 kV, and 230 kV Structures

Braced post and line post insulators are limited to a line angle of 6 degrees based on the limited compression capacities of these insulators. Insulator capacities shall be obtained from manufacturer.

8.1.1.5 General

The same insulator type can be used for concrete and steel poles. Insulator attachments for post insulators are required to be provided by thru-bolting standard insulators to the pole structures.

Solar BOT Scope Book: Appendix 2 High Voltage Overhead Transmission

Appendix 2: High Voltage Overhead Transmission

Dead-end and suspension insulators are required to be attached to the poles via vangs on steel poles or pole-eye plates on concrete poles.

8.1.1.6 Conductor and Shield Wire Vangs

Standard conductor and shield wire attachment vangs on all steel poles shall be ¾ inch plate with 1 1/8 inch diameter holes and 1 ½ inch radius and shall be the same on both ends.

Conductor attachment vangs on concrete poles will be 60,000 or 70,000 pound strength pole-eye plates mounted with 7/8 inch diameter all-thread rods, similar to those provided by Hughes Brothers in Lincoln, Nebraska.

8.1.1.7 Guy Vangs

Standard guying vangs on all steel poles shall be ¾ inch plates with 1 1/8 inch diameter holes and 1 1/2 inch radius and shall be the same on both ends. All guy attachment vangs on all concrete poles will be 60,000 or 70,000 pound strength pole-eye plates mounted with 7/8 inch diameter all-thread rods, similar to those provided by Hughes Brothers in Lincoln, Nebraska.

8.1.1.8 Polymer Insulator Standard Drawing

Attachment 1 has detailed drawings of the Entergy Standard Insulator drawings for 115 kV, 138 kV, 161 kV and 230 kV voltages. Seller shall use the Entergy Standard Insulators and must verify they meet the requirements for the design. The drawing includes the following information:

- Braced Post Insulators
- Horizontal Line Post Insulators
- Suspension Insulators
- Dead-End Insulators
- Minimum Flashover Characteristics
- Minimum Leakage Distance

8.2 Transmission Line Lightning Protection Design

8.2.1 Reference Guides

IEEE Std. 1243-1997	Guide for Improving the Lightning Performance of Transmission Lines
EPRI	Handbook for Improving Overhead Transmission Line Lightning Performance
EPRI	AC Transmission Line Reference Book - 200kV and Above
EPRI	Guide for Transmission Line Grounding
EPRI	Outline of Guide for Application of Transmission Line Surge Arrestors – 42 to 765 kV

Where applicable Seller shall apply the following parameters during the design process.

8.2.2 GFD

The GFD varies greatly throughout Entergy’s transmission system and average from 2-7 flashes/Km²/yr. However, the GFD for any area for a particular year can be more than 3X the historic average. Therefore, Entergy’s design parameters do not consider the GFD for the specific line but assume the standard design

Appendix 2: High Voltage Overhead Transmission

methods will ensure an adequate reliability throughout the system no matter the GFD of any particular location.

8.2.3 Structure BIL

Although local atmospheric conditions can affect the ability of air to insulate against a flashover the typical breakdown rate for a negative dry arc is 650 kV per meter. Therefore, the structure BIL is 650 kV X air gap in meters.

It is very difficult to maintain an acceptable BIL for distribution circuits on a transmission line structure. In order to maintain acceptable lightning performance when attached to tall shielded transmission structures, fiberglass arms and transmission class insulators are required.

Distribution underbuild is considered a last resort for new construction. It complicates maintenance for both organizations.

8.2.4 Shield Wire Installation

The installation of a shield wire is the required method of lightning protection.

8.2.5 Shield Wire Type and Size

The size and type of shield wire used will be determined by needs other than that required for lightning protection, such as fault current. Any of Entergy's standard shield wires conforming to the parameters set out in the referenced guideline will be adequate for the lightning protection of the line. Note: Supporting distribution phases on transmission structures exposes transmission shield wire to long duration distribution faults for which it was not designed. Therefore, a neutral conductor shall be bonded to each transmission structure.

8.2.6 Shielding Angle

The shielding angle, as measured at the structure from the vertical plane of the shield wire clamp to the conductor clamp, shall be no more than 25° for structures adjacent to spans averaging less than 150 feet above ground level. The required shielding angle on structures where the average conductor height is greater than 150 feet above ground level need to be designed on a case by case basis and shall be subject to approval from Buyer. The average height taken as the height at the structure minus 2/3 the sag.

On single pole structures with one shield wire, the shielding angle shall be checked to the top conductor as well as to the bottom conductor opposite the shield wire attachment.

On H-type structures, the shielding angle shall be checked for each shield wire to its corresponding outer conductor. Unless the distance between the shield wires exceeds 60 feet, the shielding angle to the middle conductor is not considered.

8.2.7 Maximum Grounding Resistance

The maximum allowable grounding resistance shall be obtained as specified in Section 8.3.

8.2.8 Lightning Arrestors

Lightning arrestors shall be used on transmission lines only in cases where a shield wire cannot be installed (e.g., clearance near an airport), the maximum allowable grounding resistance cannot be obtained, or adjacent to extremely long spans where the lightning protection software shows the shield wire is insufficient.

Appendix 2: High Voltage Overhead Transmission

8.3 Grounding and Cathodic Protection

This section covers the design of the grounding and cathodic protection systems for concrete and steel structures for transmission lines.

8.3.1 Grounding

8.3.1.1 Grounding Systems

Entergy's steel and concrete pole structures shall be "effectively grounded" as defined in Section 2 of the NESC. Shield wires are constructed, along with the associated grounding system, on all of Entergy's transmission lines for lightning protection. The use of proper structure grounding will reduce the ground resistance at the structures and will reduce line outages due to lightning strikes.

8.3.1.2 Steel Structure Grounding System

Steel poles shall be bonded to the shield wire by a copperweld jumper. The pole then acts as a ground rod to the ground line. Because the coating at the bottom of direct embedded steel poles insulates the steel, direct embedded poles shall be grounded. This grounding shall be done with ground rods driven into the earth and bonded to the pole. The same grounding is used to ground a steel pole bolted to a concrete pier or set in a concrete pile. Steel poles socketed into steel piles shall be bonded to the steel pile.

8.3.1.3 Concrete Structure Grounding System

Concrete poles shall be bonded to the shield wire through the grounding clip and a terminal lug at the pole top by a copperweld jumper. A copperweld wire shall then run down the pole to another terminal lug below ground. The wire may be internal or external. There are four options for grounding the direct buried pole: (1) connect the ground wire to the pancake at pole bottom; (2) extend the ground wire from the pancake to the ground rod; (3) connect the ground wire from the terminal directly to the ground rod; and (4) connect the ground to the substation ground grid using 4/0 copper. Ground wires shall be continuous (no splices). For concrete poles set in steel piles, the ground wire shall be extended from the bottom lug and bonded to the pile.

8.3.1.4 Guy Wire Grounding System

In accordance with NESC requirements, guy wires shall be bonded directly to the steel structure or to the ground wire on a concrete structure using a copperweld wire bonded to the guy wire.

8.3.1.5 Achieving Desired Structure Resistance

Tests to verify that the required footing resistance has been obtained using the standard methods shall be performed by Seller.

Seller shall test for grounding resistance, which shall not be greater than:

69 kV & 115kV 13 ohms

138 kV & 161 kV 10 ohms

230 kV 7 ohms

345 kV & 500 kV (H-frames) 18 ohms

There are two acceptable methods to achieve these requirements: (1) driving additional rods and (2) installing a counterpoise that consists of 100 feet of conductor buried 18" deep parallel to the line.

Appendix 2: High Voltage Overhead Transmission

8.3.1.6 Grounding at Substations

Bonding of Transmission Line Shield Wire to Substation Ground Grid

Electrical currents can be introduced on shield wires from a variety of sources. To prevent these currents from arcing across mechanical connections to get to the substation ground grid, a bonding conductor shall be provided.

The following common shielding configurations and requirements shall be permitted are detailed below:

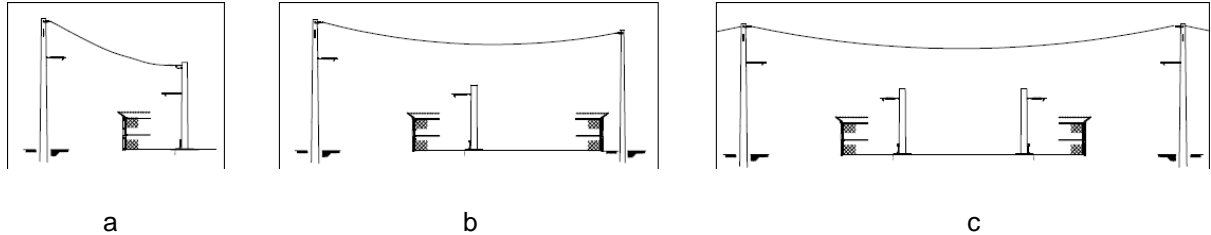

a. Shield wire attached to Substation pull-off structure

Generally, the transmission line will be dead-ended outside the substation and the shield wire slack span into the station will be positively grounded to the pull-off tower with a jumper and the pull-off tower will be connected to the substation ground grid. It is the responsibility of the substation to make these connections. The last transmission structure in the immediate vicinity of the station shall not be bonded to the substation ground grid unless a specific grounding analysis is performed.

b. Shield wire across station to dedicated shield wire pole

Since the shield wire pole is usually installed within close proximity to the substation; it shall be bonded to the substation ground grid. The last transmission structure in the immediate vicinity of the station shall not be bonded to the station grid unless a specific grounding analysis is performed.

c. Shield wire across station to exiting transmission line structure

One of the transmission structures on either side of the station shall be bonded to the substation ground grid. The structure selected for bonding shall be the one closest to the station or having the fewest physical obstacles between the structure and the station.

8.3.2 Cathodic Protection

The cathodic protection system is a method of protecting steel transmission line structures from corrosion, generally at the ground-line where moisture can mix with air to cause corrosion and thus deterioration and loss of strength of the structures. The protection system used is to attach either magnesium or zinc anodes to the structure.

These anodes provide sacrificial protection for the steel in the structures.

8.3.2.1 Soil Investigations

The soil investigation shall include soil corrosion recommendations to determine the need for anodes and the number required for each structure.

8.3.2.2 Anode Types

Magnesium anodes shall be used except that, in areas such as coastal marshes, zinc anodes may be used where recommended over magnesium anodes by the corrosion engineer based on in-situ conditions

Appendix 2: High Voltage Overhead Transmission

8.3.3 Structure Protection

Steel poles, steel piles and steel guy anchors shall be protected as described below.

8.3.3.1 Steel Dead-End and Guyed Structures

All buried steel (embed poles and piles) at dead-end and guyed steel structures shall be installed with anodes as shown on the Framing Drawings and provided Assembly Drawings. The number of anodes per structure shall be as recommended in the corrosion consultation report or as deemed necessary by the corrosion engineer based on in-situ conditions.

8.3.3.2 Steel Tangent Structures

Steel tangent structures are generally not installed with anodes, anodes shall be installed on structures in areas of known corrosion problems, or when structures are to be installed adjacent to a pipeline or railroad. In these cases, installation shall be in accordance with provided Assembly Drawings in Attachment 1.

Guy Anchors for Steel and Concrete Structures

The steel helix type anchors for both steel and concrete poles shall be installed with anodes.

9 STRUCTURE DESIGN CRITERIA

9.1 Steel Poles

Entergy standard structure framings are shown in Attachment 1.

9.1.1 Tubular Steel Pole Purchase Specification

Details of structure design that shall be included in the purchase specification are:

ASCE Design Manual Requirements

Material Specifications

Pole Deflection Limitations

Fabrication Requirements

Protective Coating Requirements

Cathodic Protection

Grounding Requirements

Seller shall procure (or cause to be procured) tubular steel poles from tubular steel pole vendors on the Approved Vendor List (Attachment 5) for tubular steel pole vendors and direct the vendor to provide items in conformance with their applicable standard Energy specifications.

9.1.2 General Design Requirements

9.1.2.1 General

All designs shall be in accordance with the provisions of the latest NESC, ASCE/SEI Standard 48, and the requirements stated in this document. All construction shall be Grade B, as defined in Section 24 of the NESC Code.

Appendix 2: High Voltage Overhead Transmission

9.1.2.2 Foundation Rotation

In addition to the applied loadings, all self-supported monopole and un-braced H-frame structures shall be designed with a 3 degree foundation rotation. The point of rotation is assumed to be at the ground line. Smaller foundation rotations for braced H-frame structures shall be considered on a case-by-case basis.

9.1.2.3 Deflection Limitations

The following pole deflection limitations assume 0 degree foundation rotation and shall be adhered to in the design of all poles. The percentage listed is the percent of the pole height above ground.

Table 9.1.2.3 – Deflection Limitations

Load Case / Wires	Tangent (Intact)	Running Angle (Intact)	Dead-end (Intact)	Dead-end (DE One Side)
NESC w/OLF See Loading District	10%	10%	10%	NSL
NESC without/OLF See Loading District	NSL	NSL	NSL	NSL
High Wind See Loading District	10%	10%	10%	NSL
Wind & Ice See Loading District	10%	10%	10%	NSL
Everyday No Wind or Ice - 60°F	3% ⁽¹⁾	3% ⁽¹⁾	3% ⁽¹⁾	NSL
Longitudinal Unbalance 1K at Each Phase Location	NSL	NSL	NA	NA
DE Stringing No Wind or Ice - 60°F	NA	NA	NA	1% ⁽²⁾

NA - Not Applicable

NSL - No Specified Deflection Limit

- (1) Camber if Deflection Exceeds 1%
- (2) Only if Specifically Requested

9.1.2.4 Pole Raking

For new project construction, cambering the pole when deflection exceeds 1% of the pole height above ground is the required resolution to concerns arising from what might (aesthetically) appear to be excess pole deflection.

9.1.2.5 Guyed Structures – Pre-Designed

The Designer shall select a pre-designed light duty pole, such as an SW Class H-6 equivalent, to be used as the pole in guyed framings in the pole spotting procedure. This type of pole will make available the range of heights to complete the spotting process. PLS-CADD will select the optimal pole height.

Appendix 2: High Voltage Overhead Transmission

9.1.2.6 Selection of Pre-designed Poles – Optimizing Process

To use the line optimization features PLS-CADD, the Designer must select and input the pre-designed pole types and framings most suited for the Transmission Lines. This shall include the material, framings and pole heights, types and sizes.

9.1.2.7 Pole Design and Verification Process

The purchase order for the structures selected by PLS-CADD during the optimization process is then forwarded to the pole vendor along with a calculated load tree for each pole. The vendor will then review the design of the selected poles before pricing and fabrication. In some cases the poles selected may have to be revised to meet the design criteria.

9.1.3 Procurement

To purchase the poles and associated materials, Seller shall use a type of purchase requisition known as a “White Requisition”.

“White Requisition” – This type of order is used to purchase material from Entergy’s preferred vendors including steel and concrete poles, insulators and conductors. The pole order will generally include the preferred item plus most of the assembly attachment material, such as nuts, bolts, vangs. It is the vendor’s responsibility to verify the size and number of each item. “White Requisitions” are also used to order non-stock-coded items.

9.1.4 Structure Hardware

The Entergy “Standard Structure Framings” in Attachment 1 lists the standard assemblies required for each structure framing. Each assembly drawing lists the bill of materials required for that assembly. The standard hardware parts were designed to meet the maximum tensions and loads calculated for the pre-designed structures previously described but shall be verified by the designer. Unless Buyer grants an exception in writing, poles shall be ordered with sufficient step bolt mounting provisions.

9.1.5 Grounding and Cathodic Protection

See Section 8.3 for design information regarding the required grounding and cathodic protection for steel poles.

9.1.6 Hybrid Structures

Hybrid structures, a combination of a steel top section and a concrete bottom section, shall be used where ground water conditions may cause excessive corrosion of a steel pole. For such structures, the concrete bottom piece shall directly embedded using standard embedment details. Foundation and grounding details are discussed in Section 10 and Section 8.3, respectively.

9.2 Concrete Poles

This section covers the design and analysis of concrete pole structures for single and bundled conductor transmission lines. It covers single pole, two pole, and three pole structures with direct-embedded foundations, socket-type foundations and base-plated foundations all for use on tangent, running angle or dead-end structures. All standard structure framings applicable to this work are delineated in Attachment 1.

9.2.1 Spun Pre-stressed Concrete Pole Purchase Specification

Details of structure design that shall be included in the purchase specification include:

Solar BOT Scope Book: Appendix 2 High Voltage Overhead Transmission

Appendix 2: High Voltage Overhead Transmission

ASCE and PCI Design Guide Requirements

Material Specifications Pole Deflection Limitations

Fabrication Requirements

Testing Requirements.

Seller shall select a concrete pole vendor from the list of concrete pole vendors set forth in the Approved Vendor List (Attachment 5) and direct the concrete pole vendor to provide items in conformance with their applicable standard Entergy specifications.

9.2.2 General Design Requirements

9.2.2.1 General

All concrete pole and related designs shall be in accordance with the provisions of the latest NESC, the PCI and ASCE Guide Specifications, and the requirements stated in this document. All concrete pole construction shall be at least Grade B, as defined in Section 24 of the NESC Code.

9.2.2.2 Foundation Rotation

In addition to the applied loadings, all self-supporting structures shall be designed with a 3-degree foundation rotation. The point of rotation shall be assumed to be at the ground line.

9.2.2.3 Deflection Limitations

The following pole deflection limitations assume 0-degree foundation rotation and shall be adhered to in the design of all concrete poles. The percentage listed is the percentage of the pole height above ground.

Load Case / Wires	<i>Concrete Structure Type</i>			
	Tangent (Intact)	Running Angle (Intact)	Dead-end (Intact)	Dead-end (DE One Side)
NESC w/OLF See Loading District	10%	10%	10%	NSL
NESC without/OLF See Loading District	2%	2%	2%	NSL
High Wind See Loading District	10%	10%	10%	NSL
Wind & Ice See Loading District	10%	10%	10%	NSL
Everyday No Wind or Ice - 60°F	1%	1%	1%	NSL
Longitudinal Unbalance 1K at Each Phase Location	NSL	NSL	NA	NA
DE Stringing No Wind or Ice - 60°F	NA	NA	NA	1%

NA - Not Applicable

NSL - No Specified Deflection Limit

9.2.2.4 Pole Raking

Where deflections under the everyday load case exceed 1% of the above ground pole height as described in Section 9.2.2.3, but do not exceed 2% the pole shall be raked to improve aesthetic concerns and minimize Solar BOT Scope Book: Appendix 2 High Voltage Overhead Transmission

Appendix 2: High Voltage Overhead Transmission

secondary moment effects. Where poles are to be raked, the Designer shall provide specific instructions identifying the degree to which the pole shall be raked to compensate for the calculated deflection under the everyday load case.

9.2.3 Procurement

To purchase the poles and associated materials, Seller shall use a type of purchase requisition known as a “White Requisition”.

“White Requisition” – This type of order is used to purchase material from Entergy’s preferred vendors, including steel and concrete poles, insulators and conductors. The pole order will generally include the poles plus most of the assembly attachment material, such as nuts, bolts, vangs. It is the vendor’s responsibility to verify the size and number of each item.

9.2.4 Structure Hardware

The applicable Entergy “Standard Structure Framings” included as Attachment 1 lists the standard assemblies required for each structure framing. Each assembly drawing lists the Bill of Materials required for that assembly. The standard hardware parts are designed to meet the maximum tensions and loads calculated for the pre-designed structures previously described. Unless a deviation is granted by Buyer, poles shall be ordered by Seller with sufficient mounting locations for attachment of climbing provisions.

9.3 H-Frame Design

This section covers the design of concrete and steel H-Frame structures to be used in construction of the Transmission Lines. These standard framings cover transmission structures for single and double circuit construction using standard suspension insulators. Clearance has been provided for the possible use of bundled conductors.

9.3.1 Structure Types

Standard framings are developed for single and double circuit “Light” and “Medium” (HA2) tangent ($0^\circ - 1.5^\circ$) structures and “Light” and “Medium” (HB2) small angle ($1.5^\circ - 6.0^\circ$) structures. Standard tubular steel cross arms have been pre-designed and detailed for use in “Light” and “Medium” structures.

The standard framings are based on the base assumption that steel structures will be X-braced and concrete structures will not be X-braced. The pole supplier shall determine if X-braces are required for each structure and shall detail and supply the X-braces and connection hardware if required.

Special “Uplift” framings are included for use in certain structures to address uplift forces in those structures. These structures use the “Light” cross arms with extra vangs to dead-end the conductors.

9.3.2 Cross Arm Design

The maximum allowable spans for the pre-designed standard cross arms are based on the maximum vertical load imposed on the arms. The load cases reviewed for each cross arm are NESC designated loadings with overload factors. Maximum arm deflections range from 1 inch to 2 inches.

The tubular steel cross arms are designed to support the vertical load of the various standard conductors used by Entergy on the standard H-Frame framings. The maximum loads for each of the Standard Framings are shown on the Framing Drawings.

The “Light” and “Medium” standard cross arm sizes are as follows:

Light Cross Arm – TS 6 x 6 x 3/16 inch

Medium Cross Arm – TS 8 x 8 x ¼ inch

Solar BOT Scope Book: Appendix 2 High Voltage Overhead Transmission

Appendix 2: High Voltage Overhead Transmission

Shield Wire Arm – TS 4 x 4 x 3/16 inch

The required use (loading) for the standard cross arms is as follows:

69 kV – Use the Light Cross Arm – for all conditions

161 kV – Use the Light Cross Arm – for ½ inch Ice loadings

Use the Medium Cross Arm – for 1 inch Ice loadings

230 kV – Use the Medium Cross Arm for all conditions

9.3.3 Cross Arm Assembly Details

The assembly drawings for attaching cross arms to poles are included in the voltage specific assemblies.

9.3.4 Rock Anchors

In rock formations, where screw type anchors will not penetrate the rock, rock anchors shall be used. There are two types of rock anchors available, to be selected based on in-situ conditions and engineering calculations.

9.3.5 Expanding Rock Anchors

Rods have a diameter of 1.0 inch and an ultimate strength of 36,000 lbs. The limitation of 36,000 lbs. can be overcome by using twin anchors. A more stringent limitation is that the rods are non-extendable. This prevents the expanding rock anchors from being used when the non-fractured bedrock is deeper than about four feet below the surface.

9.3.6 Grouted Rock Anchors

The anchors have a 1 ¼ inch diameter round shaft ending in a 4-inch diameter bell. The anchors can be extended with either 1 ¼" round shaft extensions or 1 ½" square shaft extensions. The anchor assembly has an ultimate strength of 70,000 lbs. The strength of the installed anchor (resistance to pullout) is dependent upon the rock type and the dimensions of the grout column. The characteristic of the rock that dominates the calculation for anchor depth is the equivalent cohesion. The installed anchor strength is calculated by multiplying the surface area of the grout column in each layer by the equivalent cohesion of the rock in that layer. For conservatism, any contribution from the overburden shall be ignored.

The High Wind and Heavy Ice Tensions shall be multiplied by 1.65 to provide a safety factor for the anchor installation. For the NESC Zone load case (NESC 250B) a safety factor of 1.0 shall be used as allowed by the code, since that load case already includes an Overload Factor of 1.65. The resulting worst case force shall be resisted by the friction between the grout column and the surrounding rock.

Anchor strength = (circumference) (column length per vertical foot) (constant of 0.9) [(layer 1 thickness)(layer 1 cohesion) + (layer 2 thickness)(layer 2 cohesion) + ...]

Seller shall procure that the anchor manufacturer calculates the required anchor depth using their software, but the effective cohesion shall be the parameter that dominates the result. For simplicity, the formula above uses just the effective cohesion. The constant 0.9 is a factor to account for the possible effects of other rock characteristics

The dimension that is to be specified is the distance along the anchor shaft from the ground surface to the bottom of the anchor. The minimum anchor length engaging rock is five feet.

The grout shall be pumped into the hole to ensure that a solid column is produced.

Appendix 2: High Voltage Overhead Transmission

9.3.7 Guying Hardware

Following are listed the strength values in Entergy's Standard Guying Assembly which limit line conductor tensions and are required for this Project.

9.3.7.1 Insulator Assembly

Entergy's Standard Polymer Dead-End Insulators have an ultimate tension capacity of 50,000 lbs. The NESC Strength Factor for insulators is 0.5, therefore the Routine Test Load (RTL or working load) of 25,000 lbs is used.

9.3.7.2 Steel Vangs (Steel Poles)

Steel Dead-End vangs are thru vangs and can be designed for any applied tensions. The NESC Strength Factor for the vangs is 1.0.

9.3.7.3 Pole Eye Plates for Conductor or Shield Wire (Concrete Poles)

The standard guying attachment is the "AS2720 Double Guying Tee" from Hughes Bros. The Ultimate Strength (maximum tension load) is 35,000 lbs per hole. The NESC Strength Factor is 1.0 for NESC Rule 250B Tensions (OLF=1.65) and 0.8 for Extreme Load Tensions (OLF=1.0) for Rule 250C.

9.3.7.4 Pole Eye Plates for Guy Wire (Concrete Poles)

The standard guying attachment is the "A2132 Heavy Dead End Tee" from Hughes Bros. The Ultimate Strength (maximum tension load) is 70,000 lbs. The Strength Factors are the same as for the above "Double Guying Tee". The maximum tension is along the guy slope, thus limiting the line tension depending on the actual guy slope.

9.3.7.5 Double Arming Bolts (Concrete Poles)

The standard bolt used in Entergy's Dead-End Assemblies is an ANSI C135.1, 7/8 inch "Double Arming Bolt". The maximum Tensile Strength is 25,400 lbs, the maximum shear strength through threads is 17,270 lbs. and the maximum shear strength through the shaft is 24,350 lbs. The shear strength through the threads is always used for the Dead-End Connection. The NESC Strength Factors are also the same as for the "Double Guying Tee". The allowable bolt strength for combination shear and tension loads, such as the guying assembly, is the calculated "interaction stress". These bolts are the limiting factor, depending on guy slope, of the line tension in the guying assembly.

9.3.7.6 Thimble Clevis

The thimble clevis used in the Dead-End Assembly has a 1 inch pin and is rated at 60,000 lbs. Ultimate Strength. The NESC Strength Factors are the same as the "Double Guying Tee".

9.3.7.7 Extension Link

The extension link is used in place of the thimble clevis when a double down-guy is used with two anchors. The link uses a 1 inch pin and is rated at 60,000 lbs. Ultimate Strength. The NESC Strength Factors are the same as the "Double Guying Tee".

9.3.7.8 Vari-Grip Dead-End

The vari-grip shall be rated for a 19#8 guy wire with an Ultimate Strength of 43,240 lbs. and 61,500 lbs. with a 19#6 guy wire. The NESC Strength Factor is 1.0.

Appendix 2: High Voltage Overhead Transmission

9.3.7.9 Turnbuckle

The turnbuckle shall be a 1" x 6" with jaw and eye ends with an Ultimate Strength of 50,000 lbs. The NESC Strength Factor is 1.0.

The following table gives the allowable line tension based on the guy assembly and guy wire slopes. All loads are in Kips.

Table 9.3.7.9 – Allowable Line Tensions based on Hardware Limitations

Assembly Part	Ultimate Strength	NESC Strength Factor	Allowable Load	Line Tension Guy Slope 1.5:1	Line Tension Guy Slope 1:1
Dead-End Insulator	50.0	0.5	25	25	25
19#8 Guys	43.2	0.9	38.9	21.6	30.6
19#6 Guys	61.7	0.9	55.5	30.8	39.4
Double Guy Tee (NESC)	35.0	1.0	35.0	19.4	24.8
Extreme Loads	35.0	0.8	28.0	15.5	19.9
Dead-End Tee (NESC)	70.0	1.0	70.0	38.9	49.6
Extreme Loads	70.0	0.8	56.0	31.1	39.7
7/8" D. A. Bolt (NESC)	T=25.4	1.0		21.2	28.0
Extreme Loads	V=17.3	0.8		17.0	23.0
1-1/2" SS Screw Anchor	70.0	1.0	70.0	38.9	49.6
Thimble Clevis (NESC)	60.0	1.0	60.0	33.3	42.5
Extreme Loads	60.0	0.8	48.0	26.7	34.0
Vari-Grip (NESC) w/ 19#8	43.2	1.0	43.2	24.0	30.6
Extreme Loads	43.2	0.8	34.6	19.2	24.5
Turnbuckle (NESC)	50.0	1.0	50.0	27.8	35.5
Extreme Loads	50.0	0.8	40.0	22.2	28.4
Extension Link (NESC)		1.0			
Extreme Loads		0.8			

9.3.8 Guyed Structure Limitations

9.3.8.1 Concrete Structures

The maximum line tension that can be applied on a guyed concrete structure is limited by the combined stress on the 7/8 inch D. A. Bolts, where the maximum guy tension is 18.0 kips on the 1.5:1 slope. The

Appendix 2: High Voltage Overhead Transmission

governing design condition, which is considerably less than the ultimate applied tensions that shall be applied on the larger standard conductors for the Hurricane loads (150 mph wind speed.).

9.3.8.2 Steel Structures

Welded steel thru vangs replace the tees and bolts on the concrete pole and these vangs shall be designed to support all of the possible applied loads. Therefore, as provided in the table, the 19#8 guys, the standard guy material, will govern the line tension limit when this guy wire is used. Where 19#6 guys are used, the anchor hardware will govern the line tension limit.

9.3.8.3 Heavy Ice Zone

In the heavy ice zones (NESC 250D zones), standard through bolts, guy tees and single 19#8 guy wire may be inadequate for larger conductors or bundled configurations. Special design considerations shall be investigated under these conditions.

9.3.8.4 Double Down-guy Assemblies

Double down-guy assemblies shall be used when it is determined that the soil is incapable of supporting the applied load with one anchor or where the loads exceed the allowable guy tension. The double down guy assembly shall consist of one attachment to the pole, a link with two rollers, and two guy wires and two anchors. Double Down-guy assemblies shall use 19#8 guy wires. The anchors shall be separated by at least five (5) feet.

9.3.8.5 Guy Anchor Groups

All standard guyed structure framings reference a particular Guy/Anchor Group which defines the structure voltage, and in turn provides the required number and size of guys, type of anchor, guy configuration and structure type.

9.3.8.6 Cathodic protection

Guy anchor assemblies shall be provided with cathodic protection by the installation of anodes.

Guy anchor assemblies shall be protected by anodes as shown on the "Guy Anchor Group" detail drawings. Refer to Section 8.3 for details.

9.4 Spacing of Dead-End Structures

Dead-end structures shall be required where necessary to carry eccentric loads developed due to conductor tensions. Such dead-end structures shall also be required where necessary as anti-cascading structures, or where they are necessary to facilitate construction. At a maximum spacing, dead-end structure shall be spaced such that no more than two reels of conductor and a single splice are needed between them. While the length of conductor contained on a reel can vary based on the conductor's diameter and unit weight, for most commonly used conductors this will result in a maximum spacing of approximately 4 miles between dead-end structures.

9.5 Considerations at Major Crossings

The Transmission Lines shall be designed to provide additional reliability at major crossings, in particular along major highway crossings serving as evacuation routes from coastal area. Design and maintenance/replacement activities will apply the following:

1. All crossing structures are non-wood, for all voltages
2. If a wood crossing structure is to be replaced, it shall be replaced with non-wood structure

Appendix 2: High Voltage Overhead Transmission

3. All highways are crossed at an angle as close to perpendicular as possible
4. No conductor or shield wire splices within two spans of the crossing span unless expressly approved in writing by Buyer
5. Where conductor/shield wire splices are unavoidable, or where they are installed during conductor maintenance, install implosive, full tension splices or shunt devices in conjunction with the conventional splice.
6. Install redundant insulator configurations on all crossings (e.g., braced post insulators, V-string insulators, semi-strain insulators, etc.)
7. Make shield wire connections more robust at the crossings (e.g., use shackles with nut, vs. shackles with pins, etc.)
8. No guys on crossing structures if possible, and where guys shall be installed, install double guys
9. Install highway crossing structures in locations difficult for vehicles to hit, e.g. behind ditches
10. Provide crash barriers on all highway crossing structures that are not installed in locations difficult for vehicles to hit

10 STRUCTURE FOUNDATIONS

This section covers the design of structure foundations.

Structure foundations shall be designed to meet the NESC District Loading and Everyday Load Cases, as discussed in Section 5.1; and considering the safety factors and deflection limitations discussed in Section 10.2. Note that loads shall generally be extracted from pole manufacturer calculations where the structure has been optimized for a high percentage of utilization. Where structures are designed in groups, the reaction used shall be that of the group (as opposed to loads derived from PLS or elsewhere for the specific location). Where manufacturer calculations are not available, foundations shall be designed for the published class/capacity of the pole used (to assure that future modifications on the line do not overestimate the foundation capacity based on the strength of the pole). Where this is not done, a notation shall be made on the plan and profile sheet stating that the foundation was determined considering actual loads in lieu of the structure's capacity.

10.1 Soil Information

The Designer shall obtain as much subsurface information as practicable. The basic sources of information are: (1) actual soil boring samples obtained from geotechnical investigations; (2) Geological maps; (3) data from existing U.S. Dept. of Agriculture maps; or (4) other Geotechnical sources (e. g., DOT files, customer soil records, etc.)

Actual soil data obtained from structure locations is preferable. Generally, soil borings are made at angle and dead-end structures and at intervals of approximately two miles within tangent runs depending on the terrain.

Soil information used in design shall be provided by Seller to Buyer.

Appendix 2: High Voltage Overhead Transmission

10.2 Design Methodology – Lateral Load

10.2.1 Program Description

The Designer shall use the computer programs Moment Foundation Analysis and Design (*MFAD*), and Foundation Analysis and Design (*FAD*) to design for lateral loads.

10.2.2 General Acceptance Criteria

The Designer shall apply the following generally accepted factors of safety for the calculated lateral loads as related to the calculated ultimate capacity of the pile and the acceptable deflection and rotation of the pile:

Description	Normal Soil
Total Ground Line Deflection ⁽¹⁾	3.0 in.
Total Fnd. Rotation ⁽¹⁾	1.5 deg.
Non Recoverable Deflection	1.0 in.
Non Recoverable Rotation	1.0 deg.
Safety Factor (Tangents)	1.2
Safety Factor (Angles/DEs) NESC 250B	1.0
Safety Factor (Angles/DEs) other load cases	1.65

(1) Additionally, for DE Structures, total foundation rotation and ground-line deflection shall be limited to 0.5 degrees and 1 inch under Everyday load case with all conductors on one side only.

10.3 Foundation Types

10.3.1 Basic Foundation Types

The Designer shall select from the following six basic foundation types typically used by Entergy on steel and concrete pole structures: Direct Embedment Foundation, Steel Pile with Socket Foundation, Cap/Base Plate Foundation, Steel Pile with Anchor Bolt Foundation, Drilled Pier with Anchor Bolts Foundation, and Concrete Pile with Steel or Concrete Pole using Socket Foundation. Seller's foundation engineer shall determine suitable foundation types and dimensions. Alternative foundation types shall only be used if expressly approved in writing by Buyer.

Foundation elements shall be designed using applicable material design specifications (e.g. AISC 360 for steel elements, ACI 318 for concrete elements, etc.)

Reveal height for concrete or steel socket piles shall be between 4 feet and 5 feet to facilitate concrete placement and to minimize required excavation for the socketed pole. Foundation height for base-plated poles shall be at least 2 feet, to raise anchor bolts above the ground and the bulk of the wet underbrush. The Designer shall require taller reveals in floodplains, where requested for constructability purposes, or where otherwise needed. The Designer shall not all reveals outside these specifications on the foundation drawings and/or staking sheet.

Appendix 2: High Voltage Overhead Transmission

10.3.2 Grounding and Cathodic Protection

The steel pile shall be designed to act as a ground for both steel and concrete structures. Socket connections and anchor bolt connections using steel piles shall be positively connected between the pole and pile using a #4 copperweld wire connected between the pole and the Two Hole NEMA Pad welded to the pile for a good ground. The cap/base plated connections shall be designed to provide a good grounded connection. Steel and concrete poles supported by concrete drilled piers shall be grounded to copperclad steel ground rods.

Where cathodic protection is required, the anodes shall be connected to the NEMA Pads as indicated on the cathodic protection detailed drawings. In general, unless an analysis for corrosion potential indicates otherwise or the structure is located in exposed bedrock, anodes will be required at all guy anchors, and dead-end or large angle structures supported on steel foundations or embedments. In general, unless local conditions warrant (brackish marsh, shared ROW with railroads or pipelines protected by impressed current cathodic protection, etc.) anodes are not usually required for tangent structures on structures supported on concrete foundations or embedments. Reference is made to Section 8.3 of this Appendix.

11 Attachments

Attachment 1 – Applicable Standard Framing and Assembly Drawings

Attachment 2 – NESC and Entergy Clearance Requirements

Attachment 3 – Quick Estimating Corona Loss Curves

Attachment 4 – Example ROW

Attachment 5 – Approved Vendor List¹

Attachment 6 – Entergy Loading Districts

¹ This Attachment provides an Approved Vendor List. This Approved Vendor List is in addition to that found in the Scope Book and is considered acceptable for use, and preferred.

Appendix 2: High Voltage Overhead Transmission

Attachment 1: APPLICABLE STANDARD FRAMING AND ASSEMBLY DRAWINGS

0'-5", SELF SUPPORTING, DE, JUMPER, VERTICAL,
SINGLE CIRCUIT, DE POLYMER, CONC

ASSEMBLY LIST		
ITEM	QTY.	ASSEMBLY/DRAWING
1	3	BLT-P-C
2	6	INSUL (SEE TABLE 1)
3	3	INSUL2 (SEE TABLE 1)
4	2	OHG-DE-XX
5	4	TEE-B-B

REFERENCE DRAWINGS		
ITEM	QTY.	ASSEMBLY/DRAWING
7	1	SGN-C
8	-	GND-C-XX
9	-	SEE MFR. DWG.
10	1	FOUNDATION TYPE T.B.D.
11	1	OHGCFG, SHT1, DET. OD
12	3	CONCFG, SHT11, DET. CJ3
13	-	PVO, SHT 1, VW PV-19
14	-	ANODE-XX (IF REQD.)

TABLE 1
VARIABLE DIMENSIONS & REF. DWGS.

	69 kV	161 kV	230 kV
PT	10'-6"	13'-0"	15'-0"
PP	9'-0"	14'-0"	16'-0"
INSUL	DEP/TRB-69-XX	DEP/TRB-161-XX	DEP/TRB-230-XX
INSUL2	JLP-69-XX	JLP-161-XX	JLP-230-XX

NOTES:
1. For General Notes, See Dwg. TMS220.

SDJA-V-DEP-C
ENTERGY SERVICES, INC.

Transmission Line Design Standard
0-5" SC S. SPPT. DE, DEP W/J, CONC
STRUCTURE DRAWING & DETAIL

STD NO. _____ SCALE: NONE

No. TMS627A0

PLLOT 1=1 SH.1 OF 1
SDJA-V-DEP-C

0	01-02-16	REPLACES DWS TAS525A0, TCS626A1, & TDS556A1	WRK	KC	ECW
NO.	DATE	REVISION	BY	CHK	APPR
	rkugl90	12/2/2015			

Appendix 2: High Voltage Overhead Transmission

Attachment 1: APPLICABLE STANDARD FRAMING AND ASSEMBLY DRAWINGS

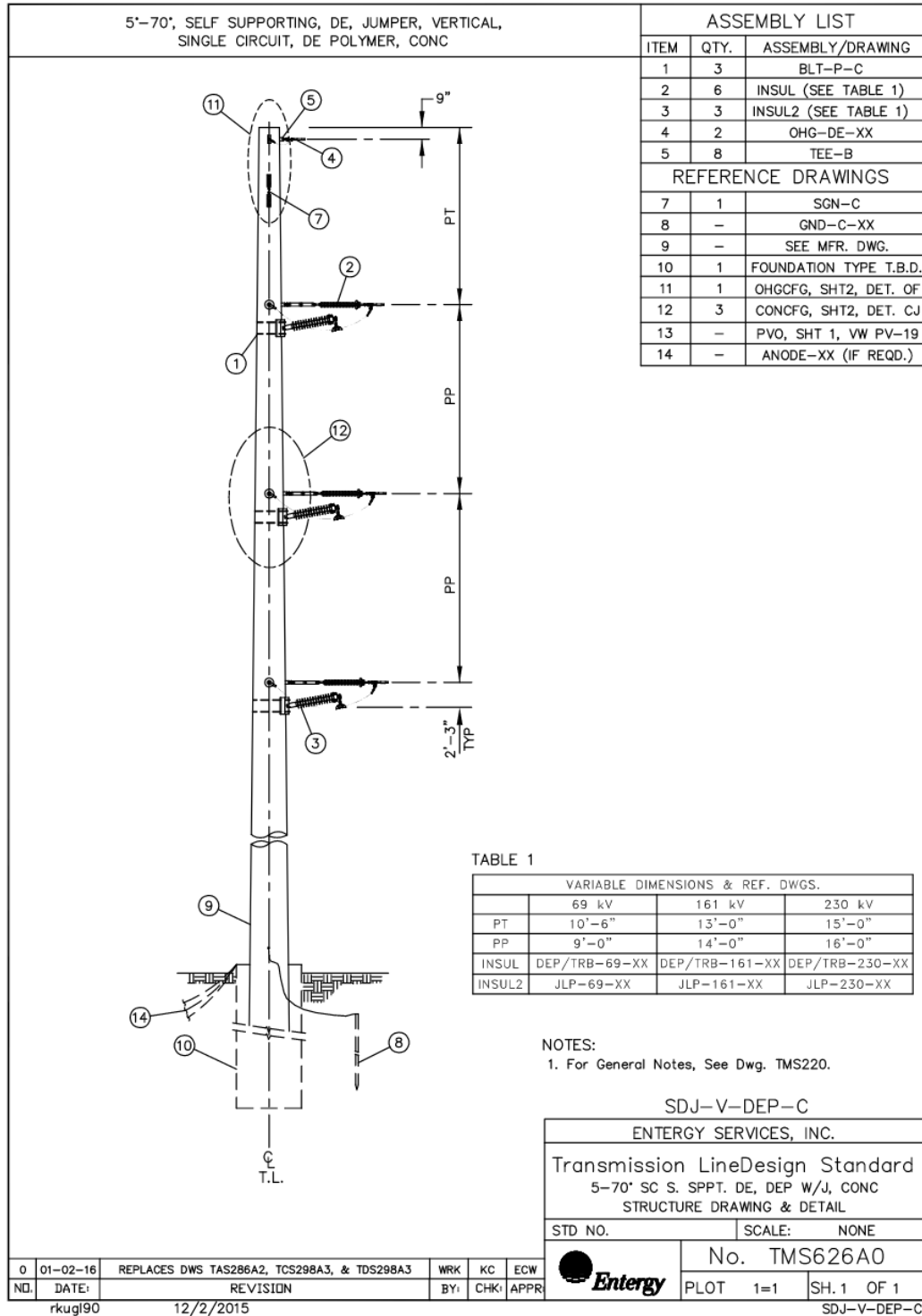

Appendix 2: High Voltage Overhead Transmission

Attachment 1: APPLICABLE STANDARD FRAMING AND ASSEMBLY DRAWINGS

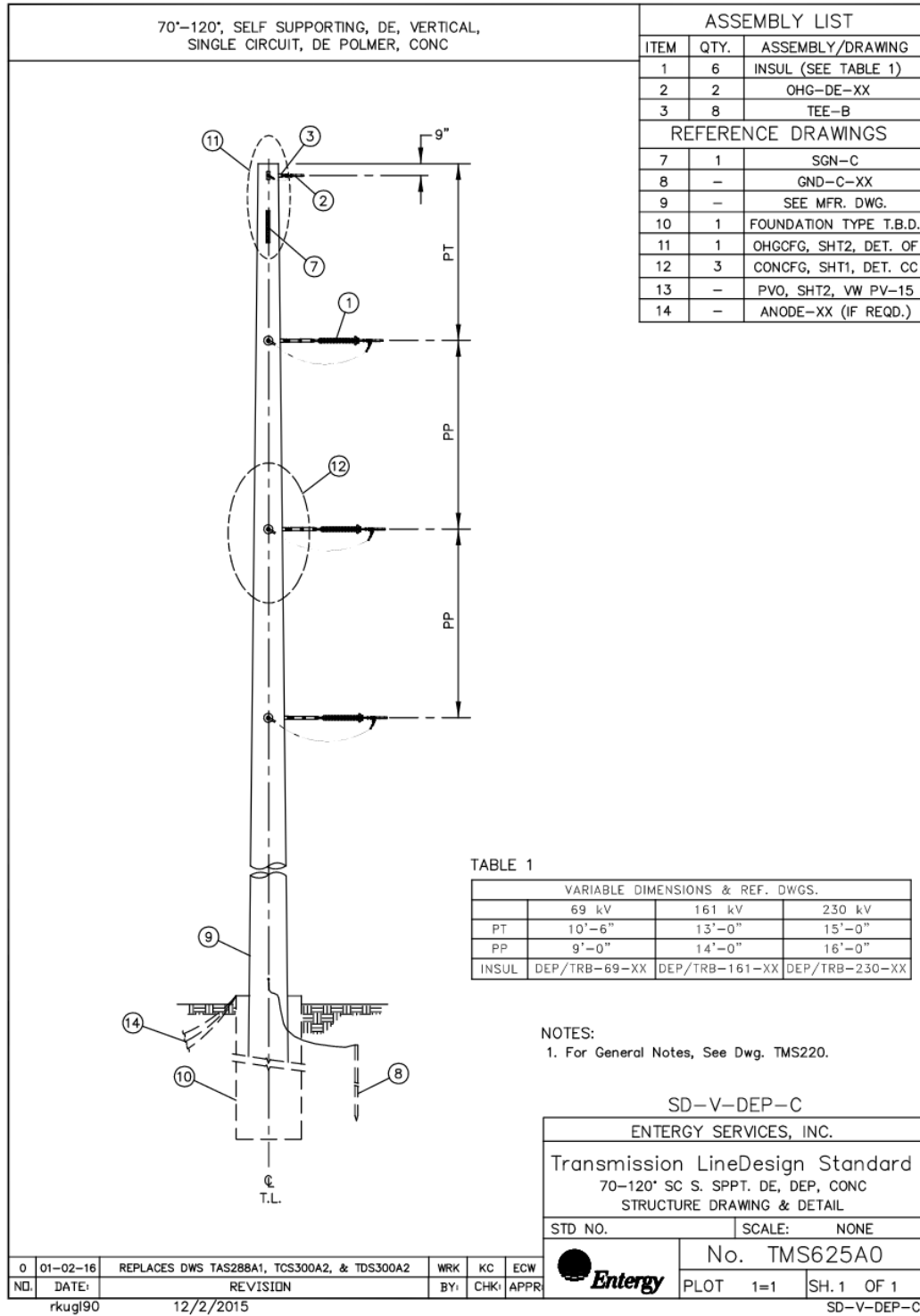

Appendix 2: High Voltage Overhead Transmission

Attachment 1: APPLICABLE STANDARD FRAMING AND ASSEMBLY DRAWINGS

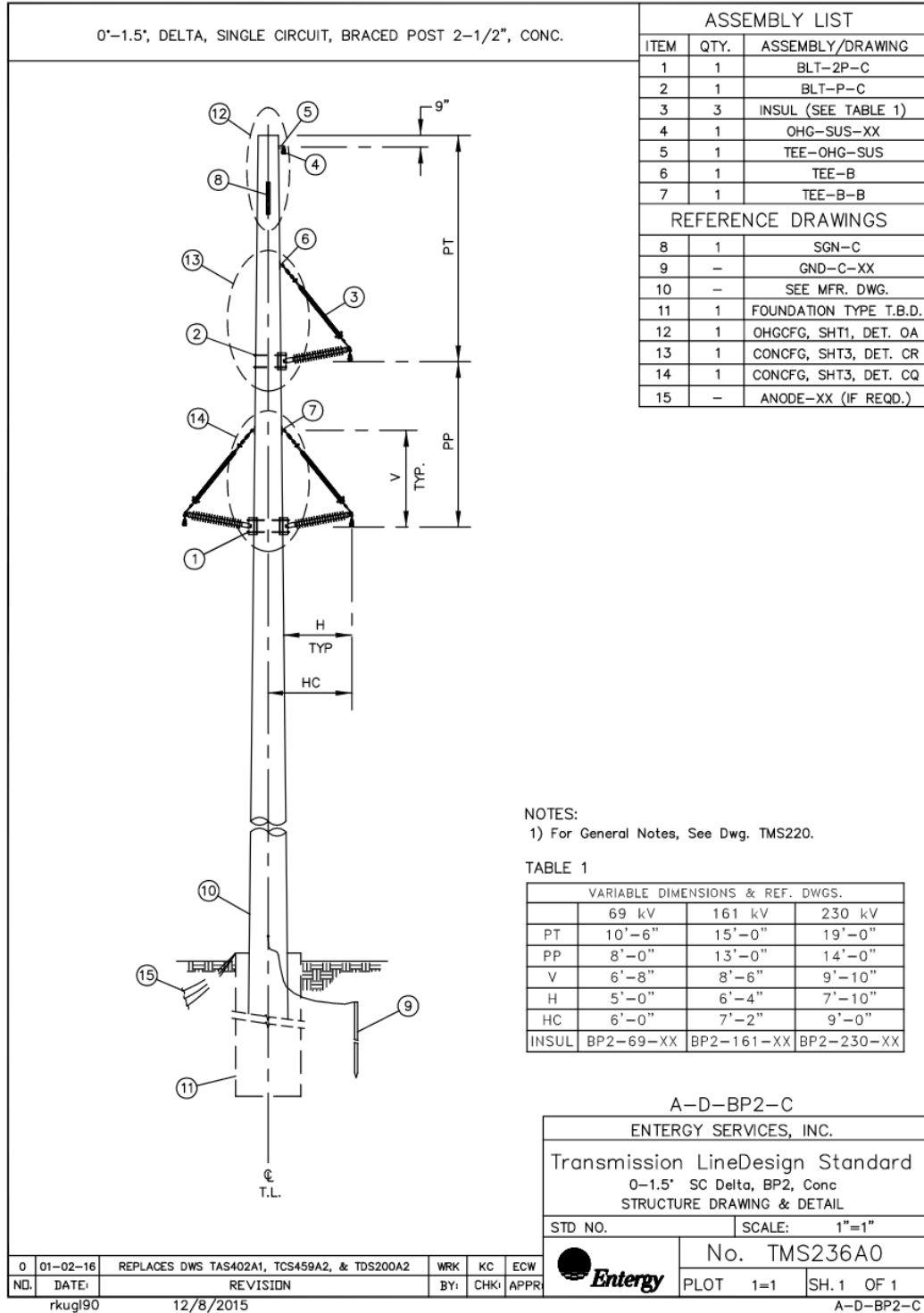

Appendix 2: High Voltage Overhead Transmission

Attachment 1: APPLICABLE STANDARD FRAMING AND ASSEMBLY DRAWINGS

6'-20", SELF SUPPORTING, VERTICAL, SINGLE CIRCUIT,
BRACED POST 2-1/2", CONC

ASSEMBLY LIST		
ITEM	QTY.	ASSEMBLY/DRAWING
1	3	BLT-P-C
2	3	INSUL (SEE TABLE 1)
3	1	OHG-SUS-XX
4	1	TEE-OHG-SUS
5	3	TEE-B
6		
REFERENCE DRAWINGS		
7	1	SGN-C
8	-	GND-C-XX
9	-	SEE MFR. DWG.
10	1	FOUNDATION TYPE T.B.D.
11	1	OHGCFG, SHT1, DET. OA
12	3	CONCFG, SHT3, DET. CR
13	-	ANODE-XX (IF REQD.)

TABLE 1 VARIABLE DIMENSIONS & REF. DWGS.			
	69 kV	161 kV	230 kV
PT	10'-6"	15'-0"	19'-0"
PP	8'-0"	13'-0"	14'-0"
V	6'-8"	8'-6"	9'-10"
H	5'-0"	6'-4"	7'-10"
HC	6'-0"	7'-2"	9'-0"
INSUL	BP2-69-XX	BP2-161-XX	BP2-230-XX

NOTES:

- For General Notes, See Dwg. TMS220.
- Line post adapters are required where line angles greater than 3', or phase transitions pull suspension hardward toward the pole. See Dwg. TMD415 for additional materials.

SC-V-BP2-C

ENTERGY SERVICES, INC.

Transmission Line Design Standard
6-20' SC VERT, BP2, CONC
STRUCTURE DRAWING & DETAIL

STD NO.	SCALE: NONE
No. TMS588A0	
PLOT	1=1 SH. 1 OF 1

0	01-02-16	REPLACES DWS TAS458A0, TCS285A2, & TDS283A2	WRK	KC	ECW
NO.	DATE	REVISION	BY	CHK	APPR
	rkugl90	12/2/2015			

	SC-V-BP2-C

Appendix 2: High Voltage Overhead Transmission

Attachment 1: APPLICABLE STANDARD FRAMING AND ASSEMBLY DRAWINGS

15°-30° SELF SUPPORTING SUSPENSION, VERTICAL,
SINGLE CIRCUIT, SUSPENSION HEAVY POLYMER w/LINK, CONC.

ASSEMBLY LIST		
ITEM	QTY.	ASSEMBLY/DRAWING
1	1	OHG-SUS-XX
2	3	INSUL (SEE TABLE 1)
3	1	TEE-OHG-SUS
4	3	TEE-B
5		
6		

REFERENCE DRAWINGS		
7	1	SGN-C
8	-	GND-C-XX
9	-	SEE MFR. DWG.
10	1	FOUNDATION TYPE T.B.D.
11	1	OHGCFG, SHT1, DET. OA
12	3	CONCFG, SHT1, DET. CA
13	-	ANODE-XX (IF REQD.)

TABLE 1

VARIABLE DIMENSIONS & REF. DWGS.			
	69 kV	161 kV	230 kV
PT	10'-6"	15'-0"	19'-0"
PP	9'-0"	14'-0"	16'-0"
INSUL	SHR-LINK-69-XX	SHR-LINK-161-XX	SHR-LINK-230-XX
HC	6'-0"	7'-0"	9'-0"

NOTES:

1. For General Notes, See Dwg. TMS220.

SF-V-SHR-C

ENTERGY SERVICES, INC.

Transmission Line Design Standard
15-30° SC S. SPPT. VERT. SUS, CONC
STRUCTURE DRAWING & DETAIL

STD NO.	SCALE: NONE
No. TMS633A0	
PLOT 1=1	SH.1 OF 1

0	01-02-16	REPLACES DWS TAS292A1, TCS304A2, & TDS304A2	WRK	KC	ECW
NO.	DATE:	REVISION	BY:	CHK:	APPR:
	rkugl90	12/2/2015			

SF-V-SHR-C

Appendix 2: High Voltage Overhead Transmission

Attachment 1: APPLICABLE STANDARD FRAMING AND ASSEMBLY DRAWINGS

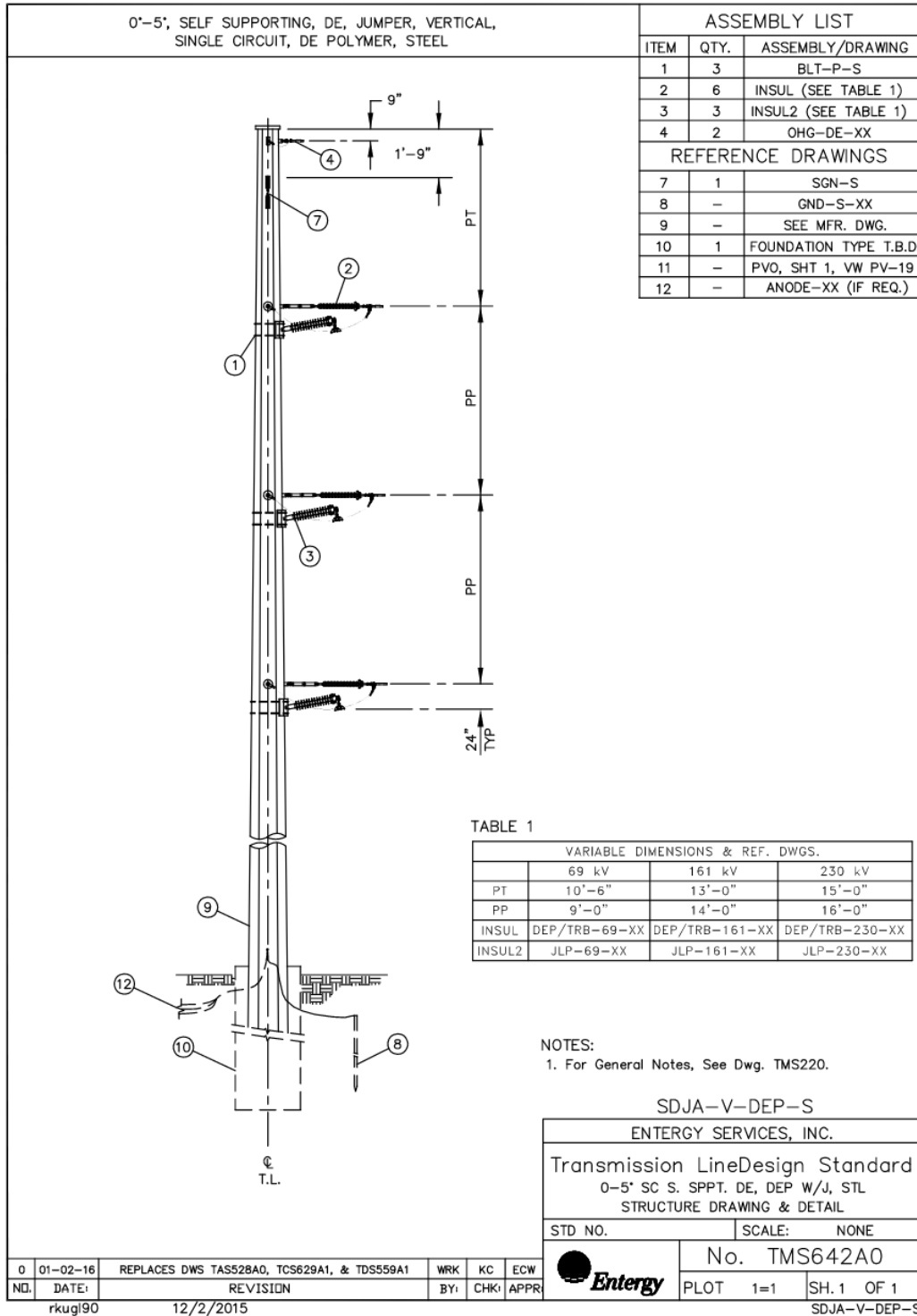

Appendix 2: High Voltage Overhead Transmission

Attachment 1: APPLICABLE STANDARD FRAMING AND ASSEMBLY DRAWINGS

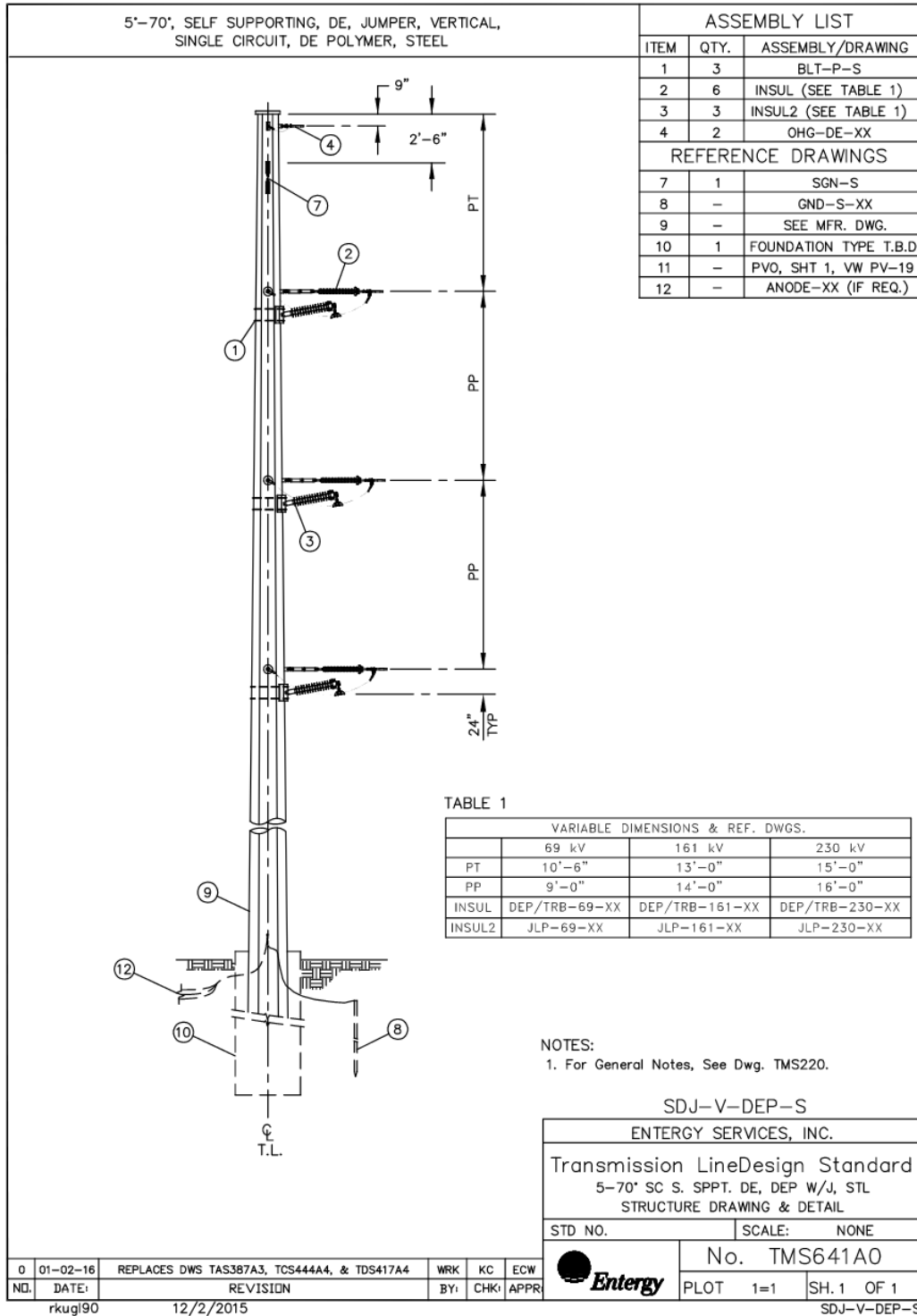

Appendix 2: High Voltage Overhead Transmission

Attachment 1: APPLICABLE STANDARD FRAMING AND ASSEMBLY DRAWINGS

70'-120', SELF SUPPORTING, DE, VERTICAL,
SINGLE CIRCUIT, DE POLMER, STEEL

ASSEMBLY LIST		
ITEM	QTY.	ASSEMBLY/DRAWING
1	6	INSUL (SEE TABLE 1)
2	2	OHG-DE-XX
REFERENCE DRAWINGS		
7	1	SGN-S
8	-	GND-S-XX
9	-	SEE MFR. DWG.
10	1	FOUNDATION TYPE T.B.D.
11	-	PVO, SHT 2, VW PV-15
12	-	ANODE-XX (IF REQ.)

TABLE 1

VARIABLE DIMENSIONS & REF. DWGS.			
	69 kV	161 kV	230 kV
PT	10'-6"	13'-0"	15'-0"
PP	9'-0"	14'-0"	16'-0"
INSUL	DEP/TRB-69-XX	DEP/TRB-161-XX	DEP/TRB-230-XX

NOTES:

1. For General Notes, See Dwg. TMS220.

SD-V-DEP-S

ENTERGY SERVICES, INC.

Transmission Line Design Standard
70-120' SC S. SPPT. DE, DEP, STL
STRUCTURE DRAWING & DETAIL

STD NO.	SCALE: NONE
No. TMS640A0	
PLOT	1=1 SH. 1 OF 1

0	01-02-16	REPLACES DWS TAS389A2, TCS446A3, & TDS419A3	WRK	KC	ECW
NO.	DATE	REVISION	BY	CHK	APPR
	rkugl90	12/2/2015			

Appendix 2: High Voltage Overhead Transmission

Attachment 1: APPLICABLE STANDARD FRAMING AND ASSEMBLY DRAWINGS

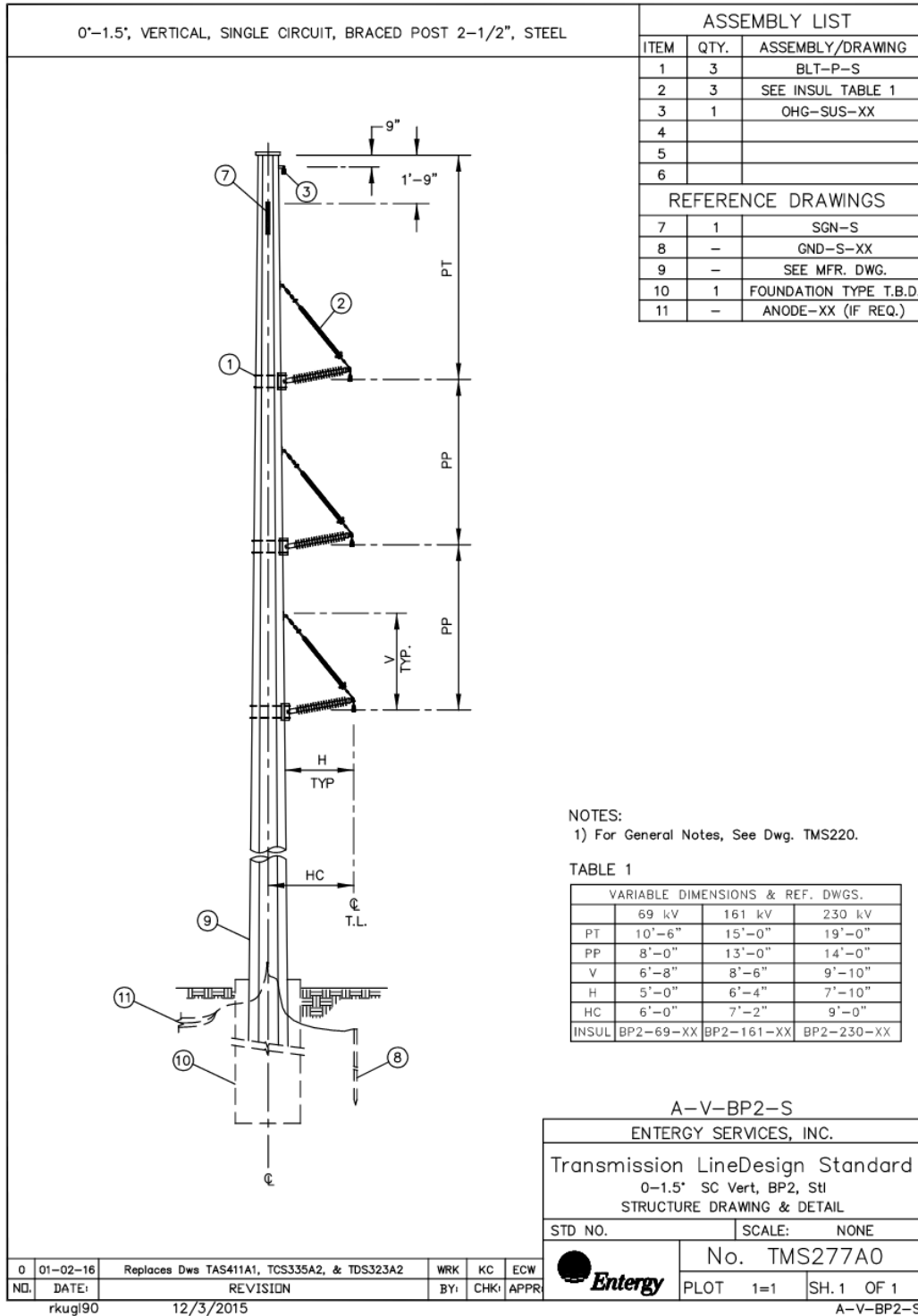

Appendix 2: High Voltage Overhead Transmission

Attachment 1: APPLICABLE STANDARD FRAMING AND ASSEMBLY DRAWINGS

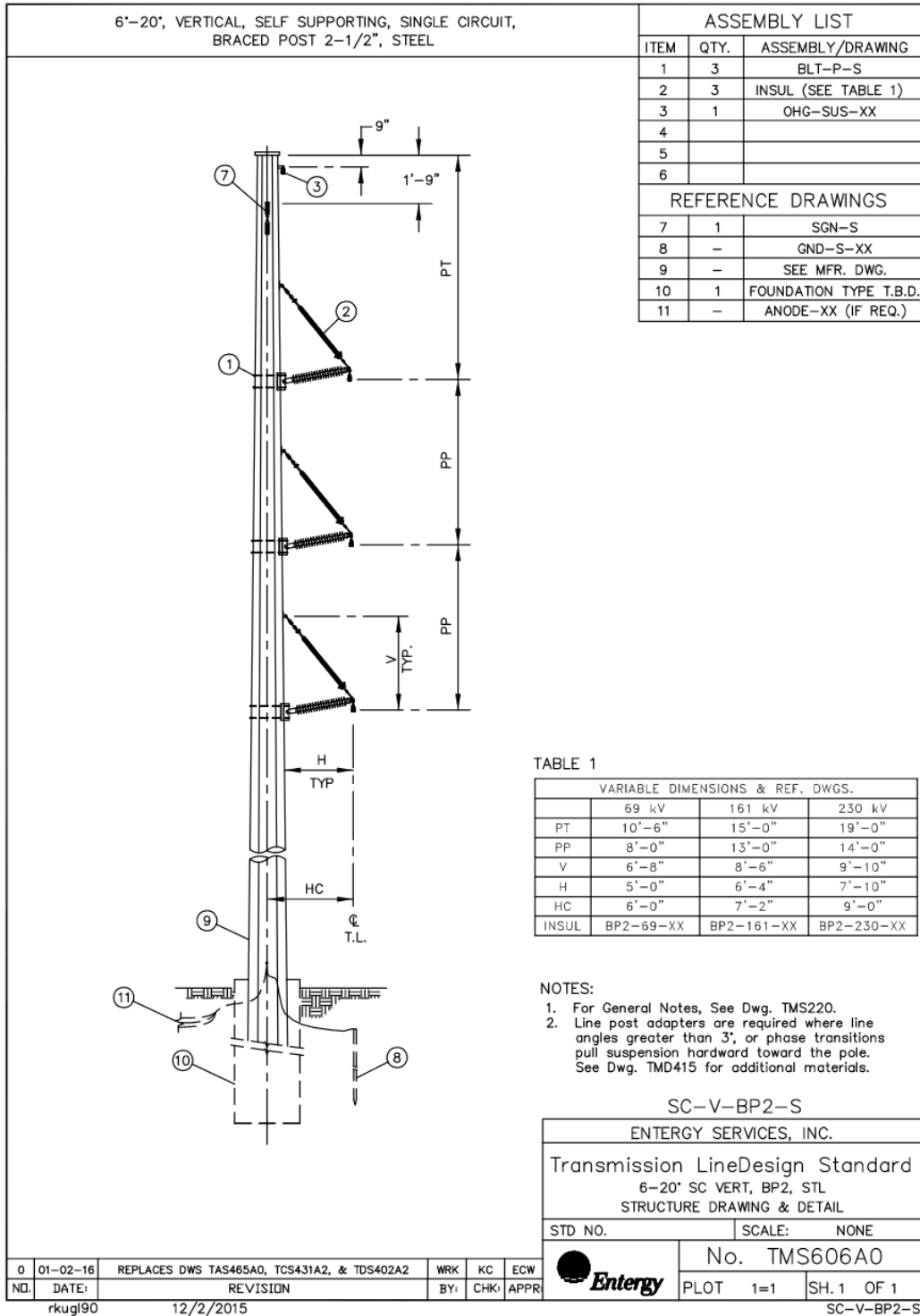

Appendix 2: High Voltage Overhead Transmission

Attachment 1: APPLICABLE STANDARD FRAMING AND ASSEMBLY DRAWINGS

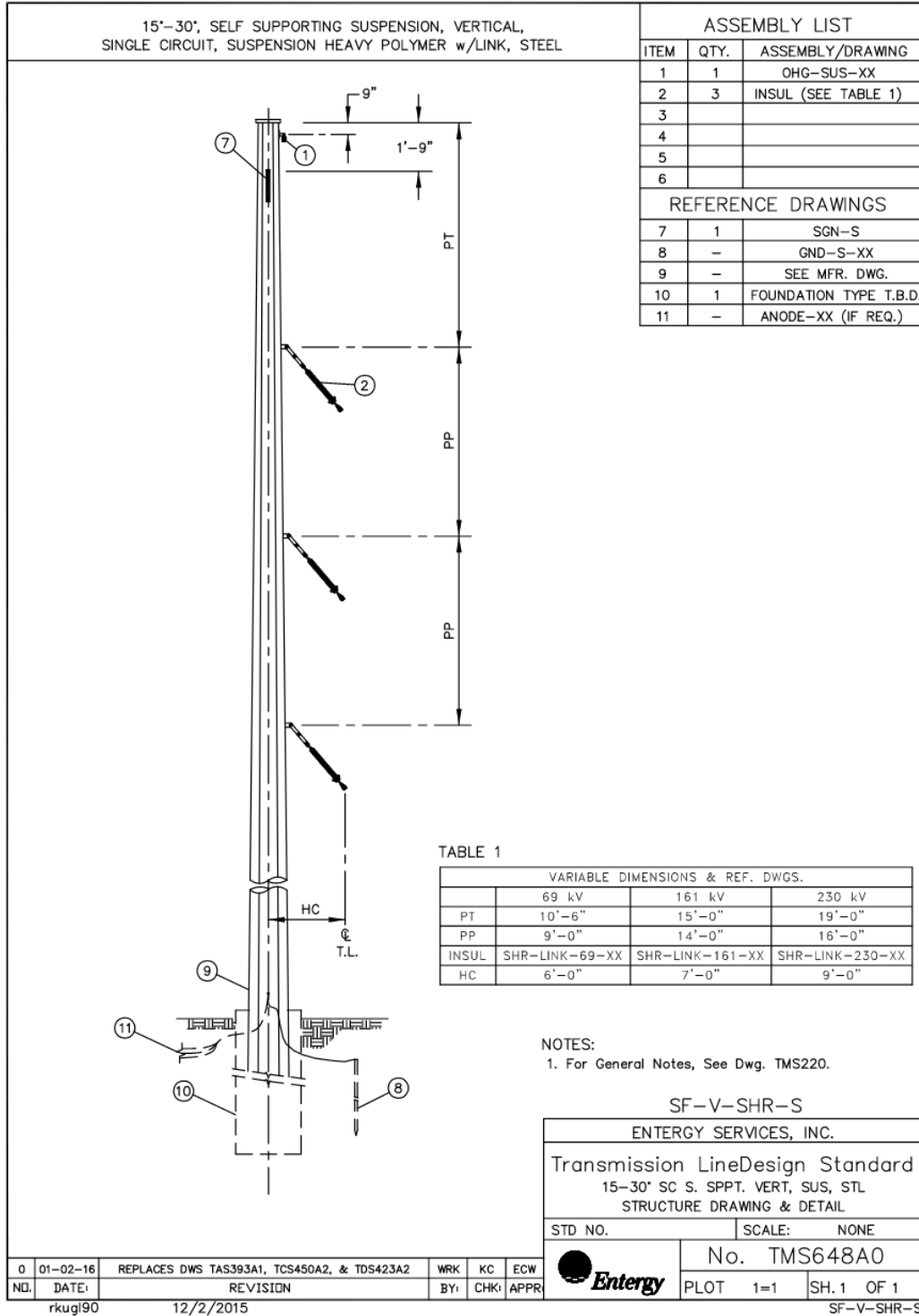

Appendix 2: High Voltage Overhead Transmission

Attachment 1: APPLICABLE STANDARD FRAMING AND ASSEMBLY DRAWINGS

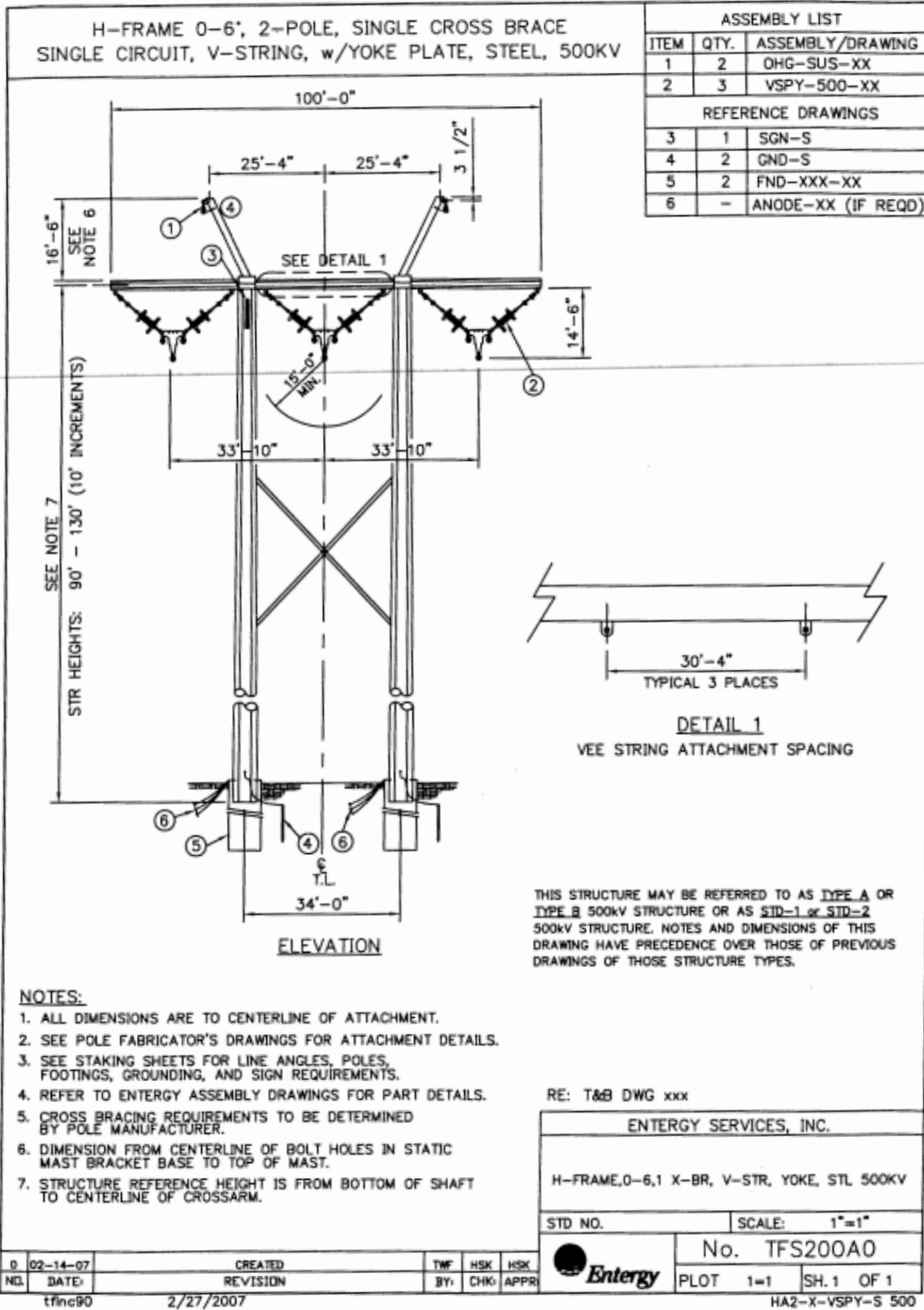

Appendix 2: High Voltage Overhead Transmission

Attachment 1: APPLICABLE STANDARD FRAMING AND ASSEMBLY DRAWINGS

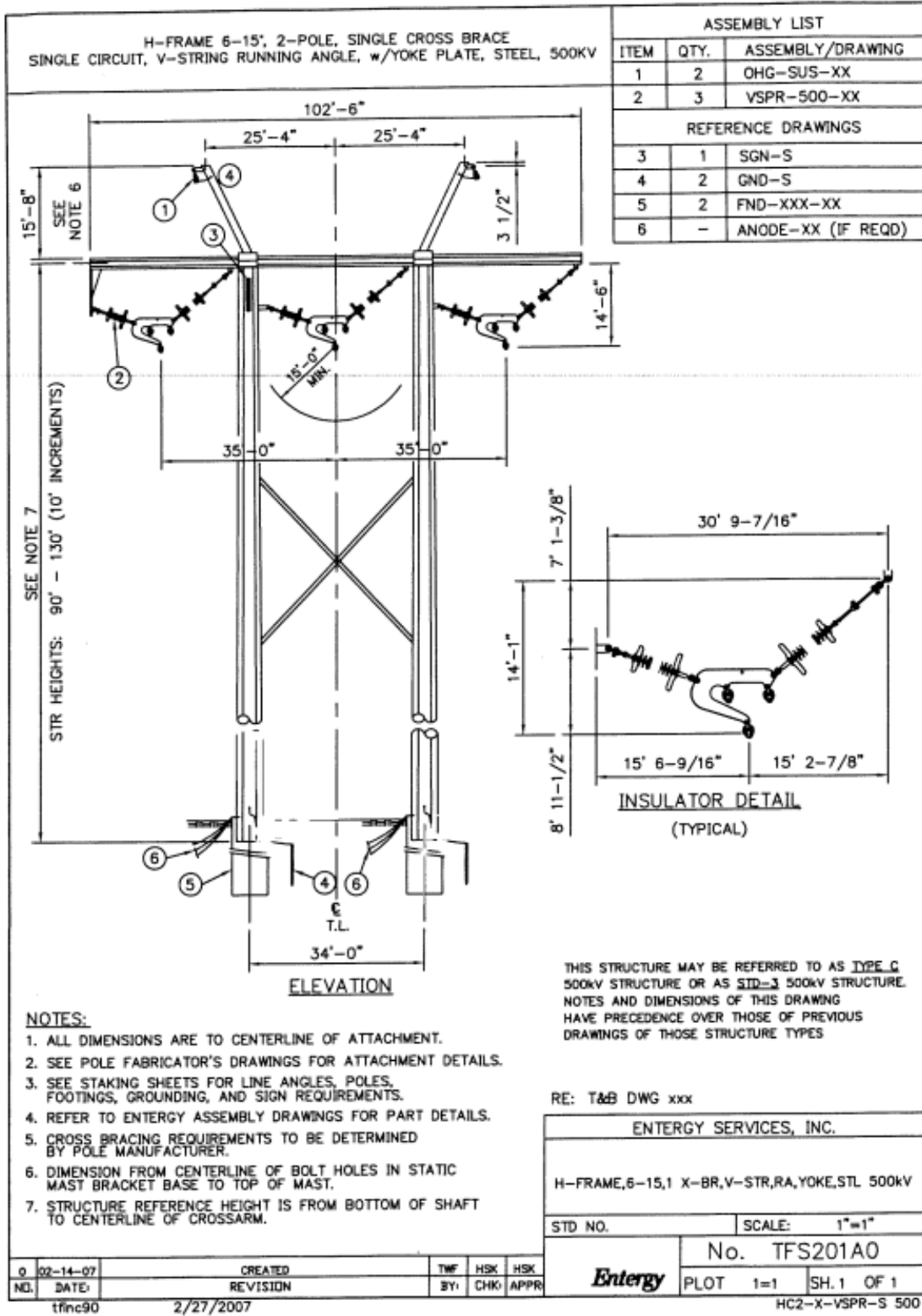

Solar BOT Scope Book: Appendix 2 High Voltage Overhead Transmission

Appendix 2: High Voltage Overhead Transmission

Attachment 1: APPLICABLE STANDARD FRAMING AND ASSEMBLY DRAWINGS

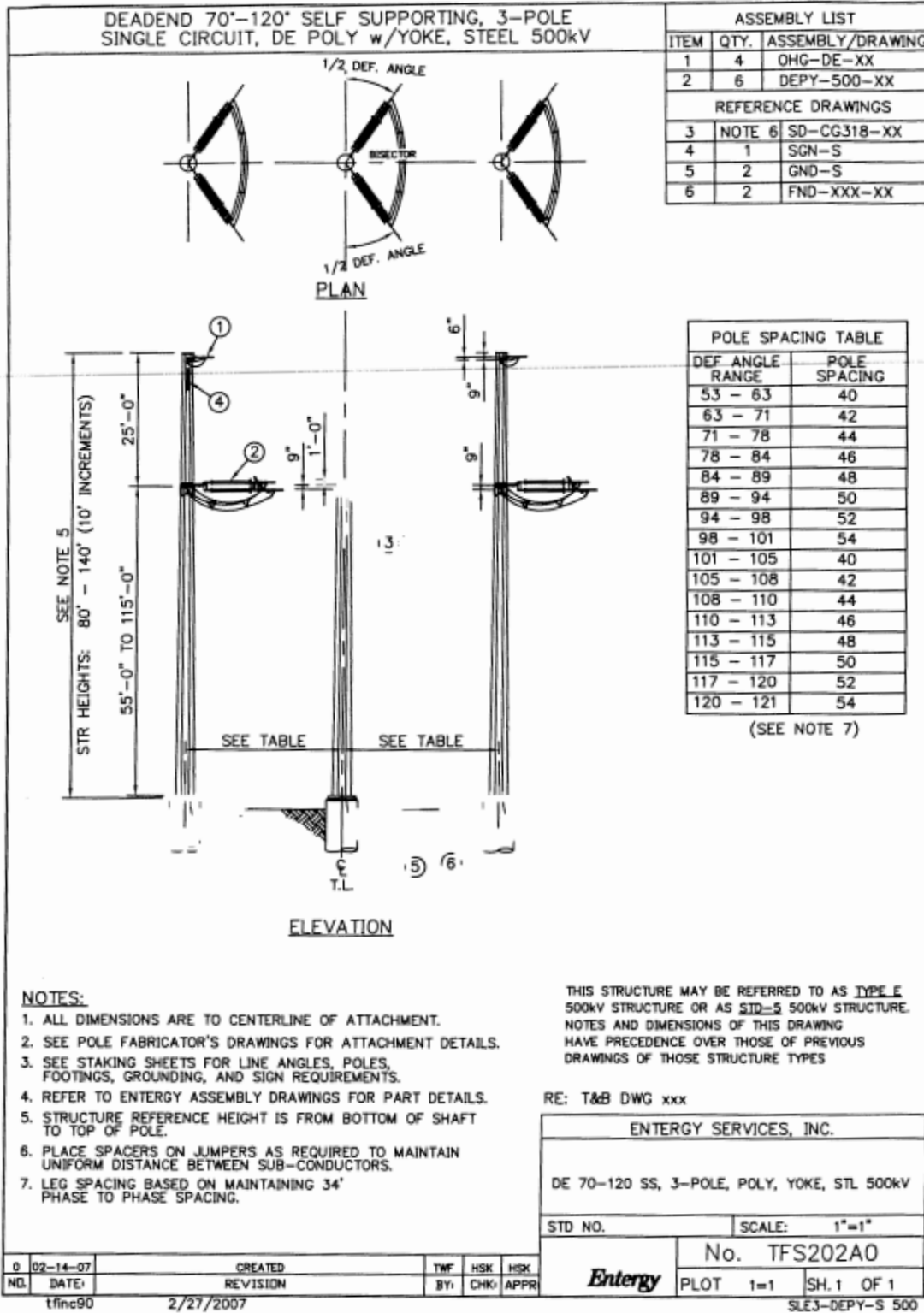

Appendix 2: High Voltage Overhead Transmission

Attachment 1: APPLICABLE STANDARD FRAMING AND ASSEMBLY DRAWINGS

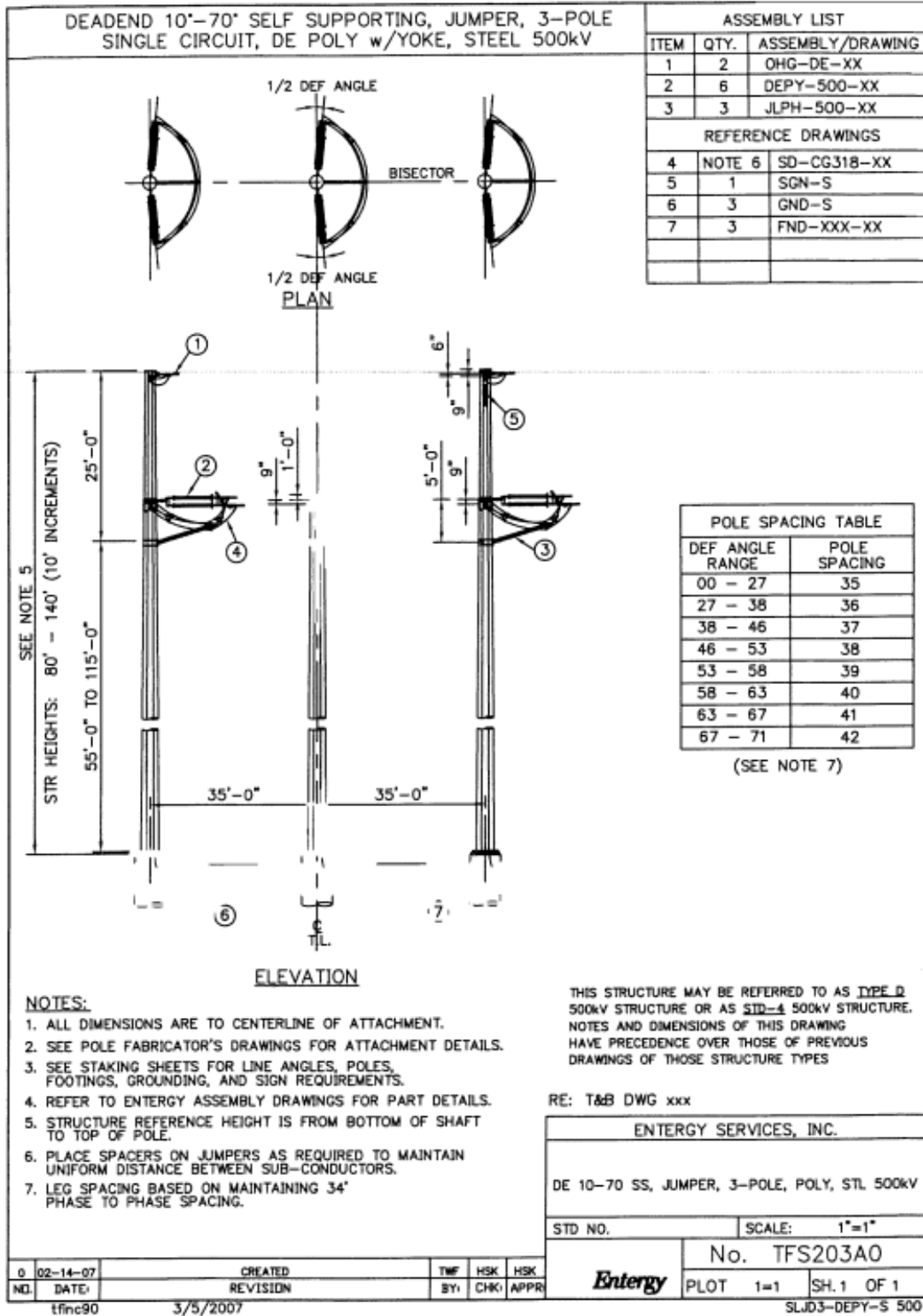

Appendix 2: High Voltage Overhead Transmission

Attachment 1: APPLICABLE STANDARD FRAMING AND ASSEMBLY DRAWINGS

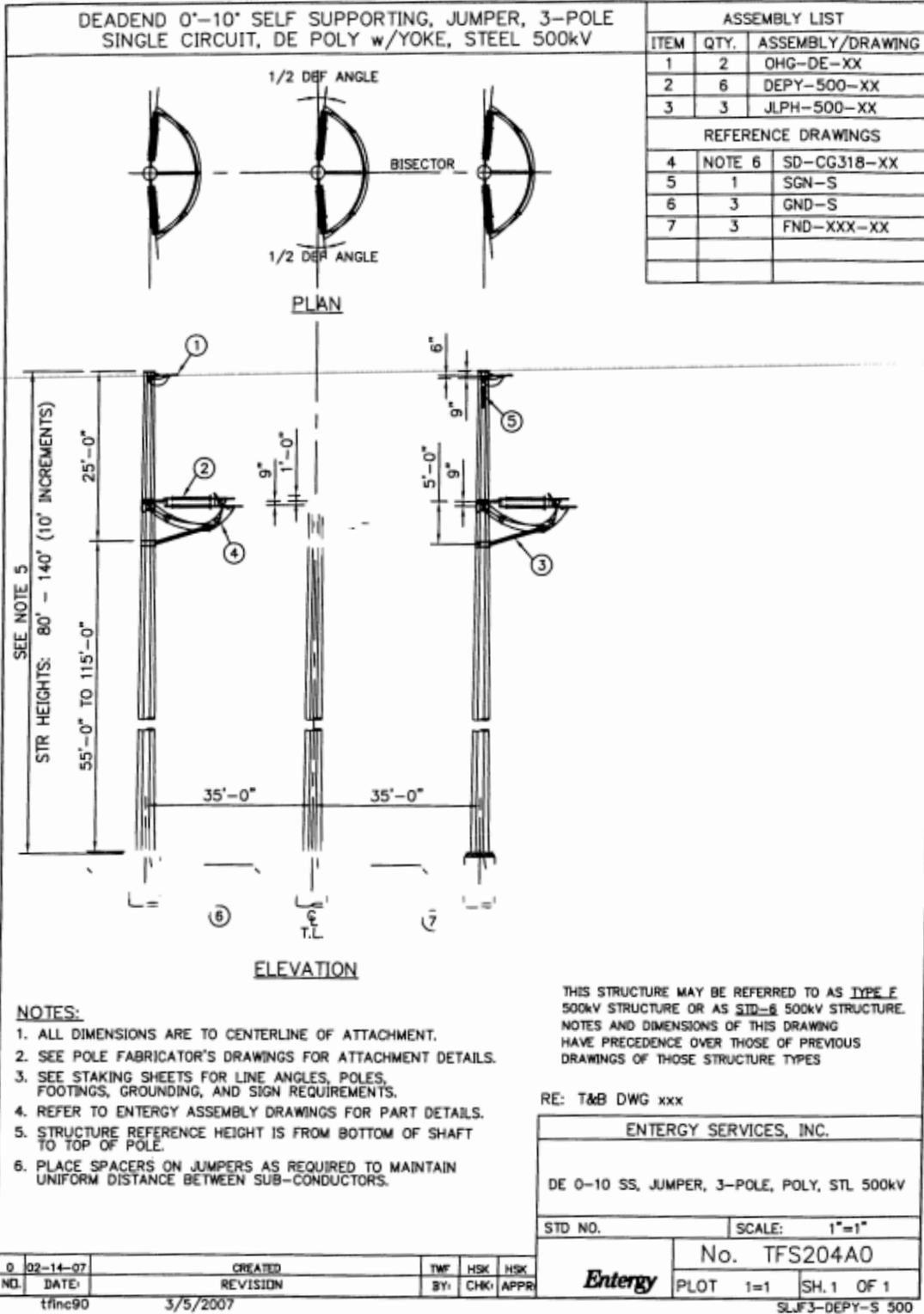

Appendix 2: High Voltage Overhead Transmission

Attachment 1: APPLICABLE STANDARD FRAMING AND ASSEMBLY DRAWINGS

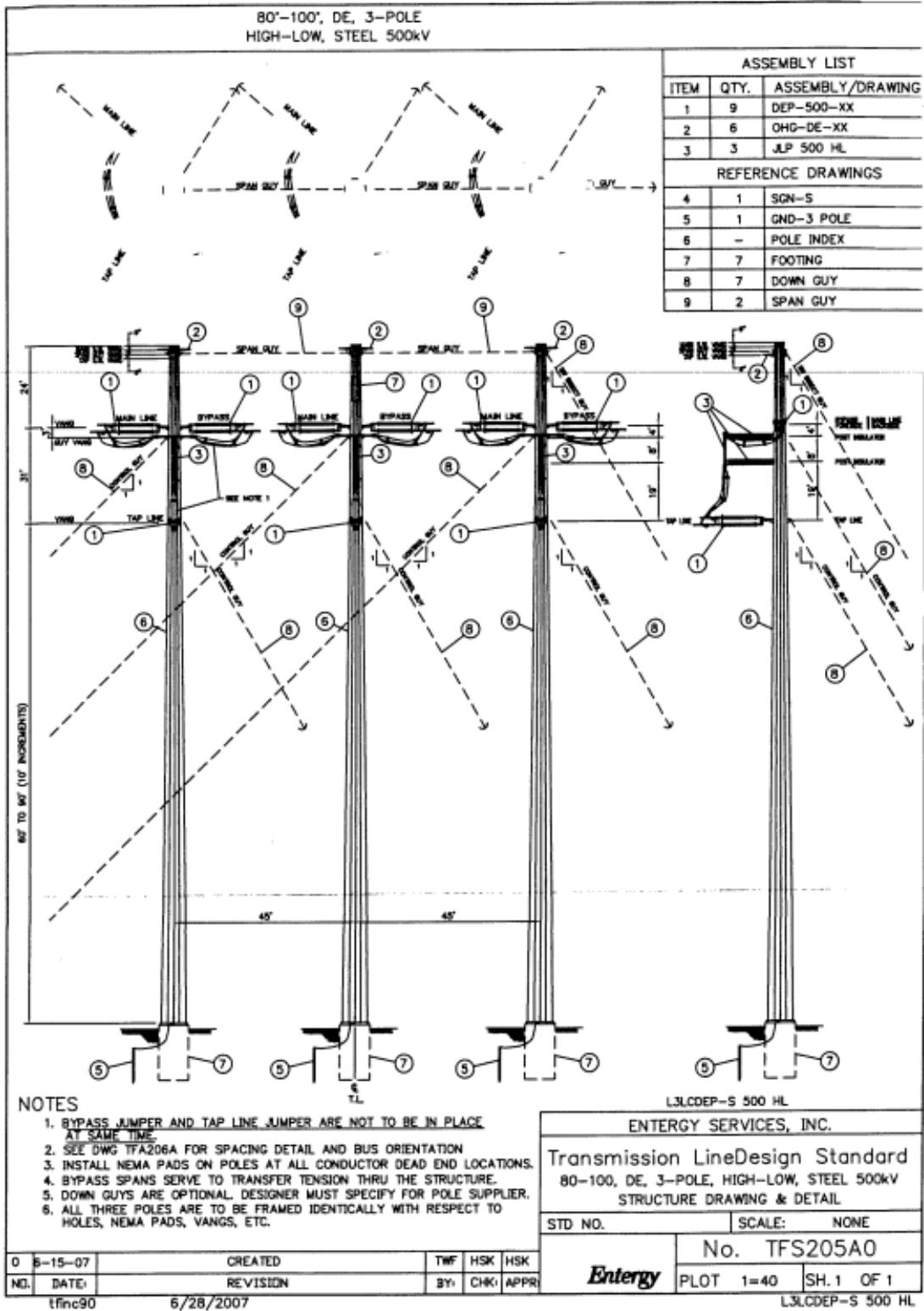

Appendix 2: High Voltage Overhead Transmission

Attachment 1: APPLICABLE STANDARD FRAMING AND ASSEMBLY DRAWINGS

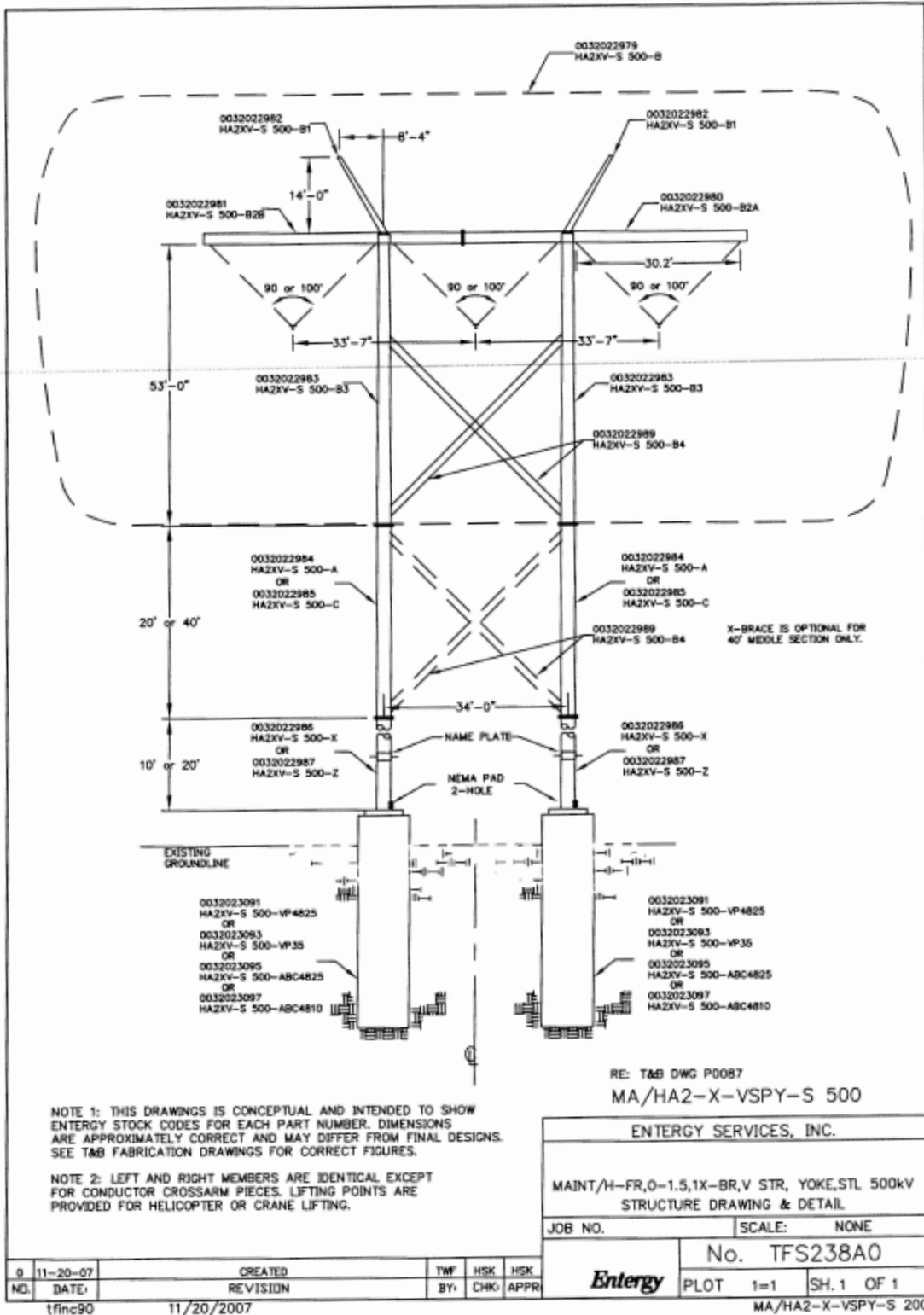

Serial Book Scope Book: Appendix 2 High Voltage Overhead Transmission

Appendix 2: High Voltage Overhead Transmission

Attachment 1: APPLICABLE STANDARD FRAMING AND ASSEMBLY DRAWINGS

LOADING TABLE *							
ITEMS	LOAD	CASE 1	CASE 2	CASE 3	CASE 4	CASE 5	CASE 6
SHIELDWIRE	T1	1760	820	1859	213	213	213
	V1	1343	3218	557	557	557	557
	L1	0	0	0	0	2036	0
CONDUCTOR	T2	9241	4278	12161	1540	1540	1540
	V2	10295	16327	5015	5015	5015	5015
	L2	0	0	0	0	0	14709
WIND ON STRUCTURE	W	10	0	25.6	0	0	0
STRUCTURE WEIGHT	VS	TO BE DETERMINED BY T&B					
LINEMAN & EQUIP. WEIGHT	V3	500					

WIRE DATA: * V, T AND L IN POUNDS, W IN PSF (OLF INCLUDED)
CONDUCTOR LOADS ARE TOTAL PER PHASE
(SEE ADDITIONAL CASE 7 BELOW)

SHIELDWIRE (SEE NOTE 7)
24 FIBER OPGW (GW2400 - 64 mm² / 528)
DIA=0.528", WT=0.362 LBS/FT, RTS=18,432 LBS
1" RADIAL ICE, 15F MAX TENSION 7833 LBS INITIAL
EVERYDAY CONDITION, 60F TENSION 2036 LBS INITIAL

7#7 ALLUMOWELD
DIA=0.433", WT=0.330 LBS/FT, RTS=19,060 LBS
1" RADIAL ICE, 15F MAX TENSION 7328 LBS INITIAL
EVERYDAY CONDITION, 60F TENSION 1740 LBS INITIAL

PHASE CONDUCTOR
(3) 954.0 KCMIL 45/7 STRAND ACSR "RAIL" (TRIPLE BUNDLED)
DIA=1.165", WT=1.0750 LBS/FT, RTS=25,900 LBS
1" RADIAL ICE, 15F MAX TENSION 13623 LBS INITIAL(SUB COND)
EVERYDAY CONDITION, 60F TENSION 4903 LBS INITIAL (SUB COND)

MECHANICAL LOADING CRITERIA:

CASE 1 - NESC MEDIUM: 4 PSF WIND ON WIRES AND STRUCTURE, 1/4" RADIAL ICE, 15° F. TRANSVERSE WIND OLF=2.50, LONGITUDINAL OLF=1.65; VERTICAL OLF=1.50.

CASE 2 - HEAVY ICE: 1" RADIAL ICE, NO WIND, 15° F. OLF=1.0

CASE 3 - HIGH WIND: 25.6 PSF WIND ON WIRES AND STRUCTURE, NO ICE, 60° F. OLF=1.00.

CASE 4 - PRECAMBER: NO WIND, NO ICE, 60° F. OLF=1.0

CASE 5 - BROKEN SHIELDWIRE: NO WIND, NO ICE, 60° F. OLF=1.0

CASE 6 - BROKEN PHASE: NO WIND, NO ICE, 60° F. OLF=1.0

CASE 7 - 25.6 PSF LONG. WIND ON STR. W/O WIRES, OLF=1.0

SPAN DATA:
WIND SPAN = 1200' at 6° Line Angle - 1600' at 0° Line Angle
WEIGHT SPAN = 1400 FEET
RULING SPAN = 1000 FEET

NOTES:

- ALL LOADS ARE ULTIMATE LOADS AND INCLUDE OVERLOAD FACTORS.
- FOR STRUCTURAL DESIGN, THE LONGITUDINAL (L), TRANSVERSE (T), AND VERTICAL (V) LOADS SHALL BE CONSIDERED TO ACT SIMULTANEOUSLY WITH WIND AND THE DEAD WEIGHT OF THE STRUCTURE.
- THE TRANSVERSE LOADS (T) INCLUDE WIND ON THE WIRE AND TRANSVERSE COMPONENT OF THE TENSION DUE TO THE LINE ANGLE.
- V1 INCLUDES 50 POUNDS FOR EACH SHIELDWIRE ASSEMBLY. V2 INCLUDES 500 POUNDS FOR EACH INSULATOR ASSEMBLY.
- V3 (LINEMAN+EQUIPMENT) = 500 LBS AT ANY ONE LOCATION.
- STRUCTURES TO BE DESIGNED FOR MAX OF EITHER 1200' WIND SPAN AT 6° LINE ANGLE OR 1600' WIND SPAN AT 0° LINE ANGLE. ABOVE TABLE REFLECTS CONTROLLING CONFIGURATION FOR EACH LOADING CONDITION. (6° CONTROLS ALL CASES)
- STRUCTURES TO BE DESIGNED TO SUPPORT ANY COMBINATION OF TWO (2) SHIELD WIRES (FIBER OR 7#7 - ONE PER PEAK). ABOVE TABLE REFLECTS THE LOADINGS DUE TO THE OPGW WHICH CONTROLS THE DESIGN
- STR. REF. HT. IS FROM BOTTOM OF SHAFT TO CL OF CROSSARM. DESIGN STRUCTURE FOR 90' TO 130' HTS. IN 10' INCREMENTS.
- PROVIDE BASE PLATE DESIGN FOR EACH STRUCTURE.
- PROVIDE SOCKET PILE DESIGN (DIAMETER, THICKNESS, AND OVERLAP) FOR EACH STRUCTURE.
- PROVIDE BASE PLATED PILE DESIGN (DIAMETER & THICKNESS) FOR EACH STRUCTURE (BASED ON 4 FT PILE REVEAL).
- SEE DRAWING STD-2 FOR STRUCTURE FRAMING.

LOAD TREE 500KV

0	11-21-07	CREATED	TWF	HSK	HSK
ND.	DATE:	REVISION	BY:	CHK:	APPR:
		12/7/2007			

HA2-X-VSPY-S 500 SK2

ENTERGY SERVICES, INC.	
Transmission Line Design Standard LOAD TREE, H-FRAME, 0'-6", 90'-130' STRUCTURE DRAWING & DETAIL	
STD NO.	SCALE: NONE
No. TFS239A0	
ENTERGY	PLOT 1=1 SH.1 OF 1

HA2-X-VSPY-S 500; SK2

Appendix 2: High Voltage Overhead Transmission

Attachment 1: APPLICABLE STANDARD FRAMING AND ASSEMBLY DRAWINGS

LOADING TABLE *							
ITEMS	LOAD	CASE 1	CASE 2	CASE 3	CASE 4	CASE 5	CASE 6
SHIELDWIRE	T1	2682	2045	2392	532	652	532
	V1	1343	3218	557	557	557	557
	L1	0	0	0	0	5000	0
CONDUCTOR	T2	14752	10669	15472	3840	3840	3604
	V2	10295	16327	5015	5015	5015	5015
	L2	0	0	0	0	0	8000
WIND ON STRUCTURE	W	10	0	25.6	0	0	0
STRUCTURE WEIGHT	VS	TO BE DETERMINED BY T&E					
LINEMAN & EQUIP. WEIGHT	V3	500					

WIRE DATA: * V, T AND L IN POUNDS, W IN PSF (OLF INCLUDED)
CONDUCTOR LOADS ARE TOTAL PER PHASE
(SEE ADDITIONAL CASE 7 BELOW)

SHIELDWIRE (SEE NOTE 7)
24 FIBER OPGW (GW2400 - 64 mm2 / 528)
DIA=0.528", WT=0.362 LBS/FT, RTS=18,432 LBS
1" RADIAL ICE, 15F MAX TENSION 7833 LBS INITIAL
EVERYDAY CONDITION, 60F TENSION 2036 LBS INITIAL
7#7 ALLUMOWELD
DIA=0.433", WT=0.330 LBS/FT, RTS=19,060 LBS
1" RADIAL ICE, 15F MAX TENSION 7328 LBS INITIAL
EVERYDAY CONDITION, 60F TENSION 1740 LBS INITIAL

PHASE CONDUCTOR
(3) 954.0 KCMIL 45/7 STRAND ACSR "RAIL" (TRIPLE BUNDLED)
DIA=1.165", WT=1.0750 LBS/FT, RTS=25,900 LBS
1" RADIAL ICE, 15F MAX TENSION 13623 LBS INITIAL (SUB COND)
EVERYDAY CONDITION, 60F TENSION 4903 LBS INITIAL (SUB COND)

MECHANICAL LOADING CRITERIA:

CASE 1 - NESC MEDIUM: 4 PSF WIND ON WIRES AND STRUCTURE, 1/4" RADIAL ICE, 15' F. TRANSVERSE WIND OLF=2.50, LONGITUDINAL OLF=1.65; VERTICAL OLF=1.50.
CASE 2 - HEAVY ICE: 1" RADIAL ICE, NO WIND, 15' F. OLF=1.0
CASE 3 - HIGH WIND: 25.6 PSF WIND ON WIRES AND STRUCTURE, NO ICE, 60' F, OLF=1.00.
CASE 4 - PRECAMBER: NO WIND, NO ICE, 60' F. OLF=1.0
CASE 5 - BROKEN SHIELDWIRE: NO WIND, NO ICE, 60' F. OLF=1.0
CASE 6 - UNBALANCED PHASE: NO WIND, NO ICE, 60' F. OLF=1.0
CASE 7 - 25.6 PSF LONG. WIND ON STR. W/O WIRES, OLF=1.0

SPAN DATA:
WIND SPAN = 1000' at 15' Line Angle
WEIGHT SPAN = 1400 FEET
RULING SPAN = 1000 FEET

NOTES:

- ALL LOADS ARE ULTIMATE LOADS AND INCLUDE OVERLOAD FACTORS.
- FOR STRUCTURAL DESIGN, THE LONGITUDINAL (L), TRANSVERSE (T), AND VERTICAL (V) LOADS SHALL BE CONSIDERED TO ACT SIMULTANEOUSLY WITH WIND AND THE DEAD WEIGHT OF THE STRUCTURE.
- THE TRANSVERSE LOADS (T) INCLUDE WIND ON THE WIRE AND TRANSVERSE COMPONENT OF THE TENSION DUE TO THE LINE ANGLE.
- V1 INCLUDES 50 POUNDS FOR EACH SHIELDWIRE ASSEMBLY. V2 INCLUDES 500 POUNDS FOR EACH INSULATOR ASSEMBLY.
- V3 (LINEMAN+EQUIPMENT) = 500 LBS AT ANY ONE LOCATION.
- STRUCTURES TO BE DESIGNED FOR 1000' WIND SPAN AT 15' LINE ANGLE. PROVIDE SPAN AND ANGLE CHART FOR 6' TO 14' LINE ANGLE.
- STRUCTURES TO BE DESIGNED TO SUPPORT ANY COMBINATION OF TWO (2) SHIELD WIRES (FIBER OR 7#7 - ONE PER PEAK). ABOVE TABLE REFLECTS THE LOADINGS DUE TO THE OPGW WHICH CONTROLS THE DESIGN
- STR. REF. HT. IS FROM BOTTOM OF SHAFT TO CL OF CROSSARM. DESIGN STRUCTURE FOR 90' TO 130' HTS. IN 10' INCREMENTS.
- PROVIDE BASE PLATE DESIGN FOR EACH STRUCTURE.
- PROVIDE SOCKET PILE DESIGN (DIAMETER, THICKNESS, AND OVERLAP) FOR EACH STRUCTURE.
- PROVIDE BASE PLATED PILE DESIGN (DIAMETER & THICKNESS) FOR EACH STRUCTURE (BASED ON 4 FT PILE REVEAL).
- SEE DRAWING STD-3 FOR STRUCTURE FRAMING.

LOAD TREE 500KV

0 11-21-07		CREATED		TWF	HSK	HSK	HC2-X-VSPR-S 500 SK3	
ND. DATE:		REVISION		BY:	CHK:	APPR:	ENTERGY SERVICES, INC.	
							Transmission Line Design Standard	
							LOAD TREE, H-FRAME, 6'-15', 90'-130'	
							STRUCTURE DRAWING & DETAIL	
STD NO.				SCALE: NONE				
							No. TFS240A0	
PLOT 1=1				SH. 1 OF 1				
tffc90		12/7/2007		Entergy		HC2-X-VSPR-S 500; SK3		

Appendix 2: High Voltage Overhead Transmission

Attachment 1: APPLICABLE STANDARD FRAMING AND ASSEMBLY DRAWINGS

LOADING TABLE *						
ITEMS		LOAD	CASE 1	CASE 2	CASE 3	CASE 4
INTACT	SW	T1	2468	2045	2111	532
		V1	1887	4576	774	774
		L1	0	0	0	0
	COND	T2	13712	10669	13608	3840
		V2	14386	23110	6950	6950
		L2	0	0	0	0
DE ONE SIDE	SW	T1	1234	1022	1055	266
		V1	1289	3082	535	535
		L1	6933	7766	4808	2019
	COND	T2	6856	5334	6804	1920
		V2	9586	15448	4622	4622
		L2	40218	40519	30442	14583
WIND ON STRUCTURE		W	10	0	25.6	0
STRUCTURE WEIGHT		VS	TO BE DETERMINED BY T&B			
LINEMAN & EQUIP. WEIGHT		V4	500			
JUMPER INSULATOR WEIGHT		V3	215			

* V, T AND L IN POUNDS, W IN PSF (OLF INCLUDED)

WIRE DATA:

SHIELDWIRE
 (2) 24 FIBER OPCW (GW2400 - 64mm² / 528)
 DIA=0.528", WT=0.362 LBS/FT, RTS=18,432 LBS
 1" RADIAL ICE, 15' F MAX TENSION 7833 LBS INITIAL
 EVERYDAY COND, 60' F TENSION 2036 LBS INITIAL

PHASE CONDUCTOR
 (3) 954.0 KCMIL 45/7 STRAND ACSR "RAIL" (TRIPLE BUNDLED)
 DIA=1.165", WT=1.0750 LBS/FT, RTS=25,900 LBS
 1" ICE, 15' F MAX TENSION 13623 LBS INITIAL (SUB CONDUCT)
 EVERYDAY CONDITION, 60' F TENSION 4903 LBS INITIAL (SUB CONDUCT)

SPAN DATA:

WIND SPAN = 750 FT (INTACT) 375 FT (DE)
 WEIGHT SPAN = 2000 FT (INTACT) 1340 FT (DE)
 RULING SPAN = 1000 FT

MECHANICAL LOADING CRITERIA:

CASE 1 - NESC MEDIUM: 4 PSF WIND ON WIRES AND STRUCTURE, 1/4" RADIAL ICE, 15' F, TRANSVERSE WIND OLF=2.50, LONGITUDINAL OLF=1.65; VERTICAL OLF=1.50.
 CASE 2 - HEAVY ICE: 1" RADIAL ICE, NO WIND, 15' F, OLF=1.0
 CASE 3 - HIGH WIND: 25.6 PSF WIND ON WIRES AND STRUCTURE, NO ICE, 60' F, OLF=1.00.
 CASE 4 - EVERYDAY: NO WIND, NO ICE, 60' F, OLF=1.0

NOTES:

- ALL LOADS ARE ULTIMATE LOADS AND INCLUDE OVERLOAD FACTORS PER MECHANICAL LOADING CRITERIA.
- FOR STRUCTURAL DESIGN, THE LONGITUDINAL (L), TRANSVERSE (T) AND VERTICAL (V) LOADS SHALL BE CONSIDERED TO ACT SIMULTANEOUSLY WITH WIND AND THE DEAD WEIGHT OF THE STRUCTURE.
- THE TRANSVERSE LOADS (T) INCLUDE WIND ON THE WIRES AND TRANSVERSE (TENSION) LOADS FROM THE LINE ANGLE AT THE STRUCTURE.
- V1 INCLUDES 50 LBS FOR SHIELDWIRE ASSEMBLY(S).
 V2 INCLUDES 500 LBS FOR INSULATOR ASSEMBLIES. (INTACT)
 V2 INCLUDES 300 LBS FOR INSULATOR ASSEMBLY. (DE)
- V4 (LINEMAN+EQUIPMENT) = 500 LBS AT ANY ONE LOCATION.
- DESIGN STRUCTURE FOR BOTH INTACT & DE ONE SIDE CONDITION.
- STRUCTURES TO BE DESIGNED TO SUPPORT ANY COMBINATION OF TWO SHIELD WIRES (FIBER OR 7#7) - ONE PER OUTSIDE LEG. ABOVE TABLE REFLECTS THE LOADINGS DUE TO THE OPCW WHICH CONTROLS THE DESIGN.
- DESIGN FOR HEIGHTS TO CONDUCTOR FROM 55' TO 115' IN 10' INCREMENTS (OVERALL HT 80' TO 140').
- PROVIDE SOCKET PILE DESIGN (DIAMETER, THICKNESS, AND OVERLAP) FOR EACH STRUCTURE.
- SEE DRAWING STD-4 FOR STRUCTURE FRAMING.

LOAD TREE 500KV 3-POLE

SLE3-DEPY-S 500 SK4 (15)

ENERGY SERVICES, INC.	
Transmission Line Design Standard	
LOAD TREE, DEADEND, 15', SS, 55'-115'	
STRUCTURE DRAWING & DETAIL	
STD NO.	SCALE: NONE
No. TFS241A0	
ENTergy	PLOT 1=1 SH. 1 OF 1

SLE3-DEPY-S 500; SK4 (15)

0	11-21-07	CREATED	TWF	HSK	HSK
		REVISION	BY:	CHK:	APPR:
tffc90		12/7/2007			

Appendix 2: High Voltage Overhead Transmission

Attachment 1: APPLICABLE STANDARD FRAMING AND ASSEMBLY DRAWINGS

LOADING TABLE *						
ITEMS		LOAD	CASE 1	CASE 2	CASE 3	CASE 4
INTACT	SW	T1	3669	3391	2944	881
		V1	1887	4576	774	774
		L1	0	0	0	0
	COND	T2	20682	17691	18884	6397
		V2	14386	23110	6950	6950
		L2	0	0	0	0
DE ONE SIDE	SW	T1	1835	1695	1472	441
		V1	1289	3082	535	535
		L1	6827	7647	4734	1988
	COND	T2	10341	8846	9442	3184
		V2	9586	15448	4622	4622
		L2	39604	39900	29977	14360
WIND ON STRUCTURE		W	10	0	25.6	0
STRUCTURE WEIGHT		VS	TO BE DETERMINED BY T&B			
LINEMAN & EQUIP. WEIGHT		V4	500			
JUMPER INSULATOR WEIGHT		V3	215			

* V, T AND L IN POUNDS, W IN PSF (OLF INCLUDED)

WIRE DATA:

SHIELDWIRE
 (2) 24 FIBER OPGW (GW2400 - 54mm2 / 528)
 DIA=0.528", WT=0.362 LBS/FT, RTS=18,432 LBS
 1" RADIAL ICE, 15' F MAX TENSION 7833 LBS INITIAL
 EVERYDAY COND, 60F TENSION 2036 LBS INITIAL

PHASE CONDUCTOR
 (3) 954.0 KCMIL 45/7 STRAND ACSR "RAIL" (TRIPLE BUNDLED)
 DIA=1.165", WT=1.0750 LBS/FT, RTS=25,900 LBS
 1" ICE, 15F MAX TENSION 13623 LBS INITIAL (SUB CONDUCT)
 EVERYDAY CONDITION, 60F TENSION 4903 LBS INITIAL (SUB CONDUCT)

MECHANICAL LOADING CRITERIA:

CASE 1 - NESC MEDIUM: 4 PSF WIND ON WIRES AND STRUCTURE, 1/4" RADIAL ICE, 15' F. TRANSVERSE WIND OLF=2.50, LONGITUDINAL OLF=1.65; VERTICAL OLF=1.50.

CASE 2 - HEAVY ICE: 1" RADIAL ICE, NO WIND, 15' F. OLF=1.0

CASE 3 - HIGH WIND: 25.6 PSF WIND ON WIRES AND STRUCTURE, NO ICE, 60' F. OLF=1.00.

CASE 4 - EVERYDAY: NO WIND, NO ICE, 60' F. OLF=1.0

SPAN DATA:

WIND SPAN = 750 FT (INTACT) 375 FT (DE)
 WEIGHT SPAN = 2000 FT (INTACT) 1340 FT (DE)
 RULING SPAN = 1000 FT

NOTES:

- ALL LOADS ARE ULTIMATE LOADS AND INCLUDE OVERLOAD FACTORS PER MECHANICAL LOADING CRITERIA.
- FOR STRUCTURAL DESIGN, THE LONGITUDINAL (L), TRANSVERSE (T) AND VERTICAL (V) LOADS SHALL BE CONSIDERED TO ACT SIMULTANEOUSLY WITH WIND AND THE DEAD WEIGHT OF THE STRUCTURE.
- THE TRANSVERSE LOADS (T) INCLUDE WIND ON THE WIRES AND TRANSVERSE (TENSION) LOADS FROM THE LINE ANGLE AT THE STRUCTURE.
- V1 INCLUDES 50 LBS FOR SHIELDWIRE ASSEMBLY(S).
 V2 INCLUDES 500 LBS FOR INSULATOR ASSEMBLIES. (INTACT)
 V2 INCLUDES 300 LBS FOR INSULATOR ASSEMBLY. (DE)
- V4 (LINEMAN+EQUIPMENT) = 500 LBS AT ANY ONE LOCATION.
- DESIGN STRUCTURE FOR BOTH INTACT & DE ONE SIDE CONDITION.
- STRUCTURES TO BE DESIGNED TO SUPPORT ANY COMBINATION OF TWO SHIELD WIRES (FIBER OR 7#7) - ONE PER OUTSIDE LEG. ABOVE TABLE REFLECTS THE LOADINGS DUE TO THE OPGW WHICH CONTROLS THE DESIGN.
- DESIGN FOR HEIGHTS TO CONDUCTOR FROM 55' TO 115' IN 10' INCREMENTS (OVERALL HT 80' TO 140').
- PROVIDE SOCKET PILE DESIGN (DIAMETER, THICKNESS, AND OVERLAP) FOR EACH STRUCTURE.
- SEE DRAWING STD-4 FOR STRUCTURE FRAMING.

LOAD TREE 500KV 3-POLE

SLE3-DEPY-S 500 SK4 (25)

ENTERGY SERVICES, INC.	
Transmission LineDesign Standard	
LOAD TREE, DEADEND, 25', SS, 55'-115'	
STRUCTURE DRAWING & DETAIL	
STD NO.	SCALE: NONE
No. TFS242A0	
	PLOT 1=1 SH. 1 OF 1

SLE3-DEPY-S 500; SK4 (25)

0	11-21-07	CREATED	TWF	MSK	MSK
1		REVISION	BY:	CHK:	APPR:
		12/7/2007			

tfinc90

Appendix 2: High Voltage Overhead Transmission

Attachment 1: APPLICABLE STANDARD FRAMING AND ASSEMBLY DRAWINGS

LOADING TABLE *						
ITEMS		LOAD	CASE 1	CASE 2	CASE 3	CASE 4
INTACT	SW	T1	4848	4711	3761	1224
		V1	1887	4576	774	774
		L1	0	0	0	0
	COND	T2	27518	24579	24058	8846
		V2	14386	23110	6950	6950
		L2	0	0	0	0
DE ONE SIDE	SW	T1	2424	2355	1881	612
		V1	1289	3082	535	535
		L1	6669	7470	4625	1942
	COND	T2	13759	12290	12029	4423
		V2	9586	15448	4622	4622
		L2	38688	38977	29284	14028
WIND ON STRUCTURE		W	10	0	25.6	0
STRUCTURE WEIGHT		VS	TO BE DETERMINED BY T&B			
LINEMAN & EQUIP. WEIGHT		V4	500			
JUMPER INSULATOR WEIGHT		V3	215			

* V, T AND L IN POUNDS, W IN PSF (OLF INCLUDED)

WIRE DATA:

<p>SHIELDWIRE</p> <p>(2) 24 FIBER OPGW (GW2400 - 64mm² / 528) DIA=0.528", WT=0.362 LBS/FT, RTS=18,432 LBS 1" RADIAL ICE, 15' F MAX TENSION 7833 LBS INITIAL EVERYDAY COND, 60' F TENSION 2036 LBS INITIAL</p>	<p>PHASE CONDUCTOR</p> <p>(3) 954.0 KCMIL 45/7 STRAND ACSR "RAIL" (TRIPLE BUNDLED) DIA=1.165", WT=1.0750 LBS/FT, RTS=25,900 LBS 1" ICE, 15' F MAX TENSION 13623 LBS INITIAL (SUB CONDUCT) EVERYDAY CONDITION, 60' F TENSION 4903 LBS INITIAL (SUB CONDUCT)</p>
--	--

MECHANICAL LOADING CRITERIA:

CASE 1 - NESC MEDIUM: 4 PSF WIND ON WIRES AND STRUCTURE, 1/4" RADIAL ICE, 15' F. TRANSVERSE WIND OLF=2.50, LONGITUDINAL OLF=1.65; VERTICAL OLF=1.50.

CASE 2 - HEAVY ICE: 1" RADIAL ICE, NO WIND, 15' F. OLF=1.0

CASE 3 - HIGH WIND: 25.6 PSF WIND ON WIRES AND STRUCTURE, NO ICE, 60' F. OLF=1.00.

CASE 4 - EVERYDAY: NO WIND, NO ICE, 60' F. OLF=1.0

SPAN DATA:

WIND SPAN = 750 FT (INTACT) 375 FT (DE)
 WEIGHT SPAN = 2000 FT (INTACT) 1340 FT (DE)
 RULING SPAN = 1000 FT

NOTES:

- ALL LOADS ARE ULTIMATE LOADS AND INCLUDE OVERLOAD FACTORS PER MECHANICAL LOADING CRITERIA.
- FOR STRUCTURAL DESIGN, THE LONGITUDINAL (L), TRANSVERSE (T) AND VERTICAL (V) LOADS SHALL BE CONSIDERED TO ACT SIMULTANEOUSLY WITH WIND AND THE DEAD WEIGHT OF THE STRUCTURE.
- THE TRANSVERSE LOADS (T) INCLUDE WIND ON THE WIRES AND TRANSVERSE (TENSION) LOADS FROM THE LINE ANGLE AT THE STRUCTURE.
- V1 INCLUDES 50 LBS FOR SHIELDWIRE ASSEMBLY(S). V2 INCLUDES 500 LBS FOR INSULATOR ASSEMBLIES. (INTACT) V2 INCLUDES 300 LBS FOR INSULATOR ASSEMBLY. (DE)
- V4 (LINEMAN+EQUIPMENT) = 500 LBS AT ANY ONE LOCATION.
- DESIGN STRUCTURE FOR BOTH INTACT & DE ONE SIDE CONDITION.
- STRUCTURES TO BE DESIGNED TO SUPPORT ANY COMBINATION OF TWO SHIELD WIRES (FIBER OR 7#) - ONE PER OUTSIDE LEG. ABOVE TABLE REFLECTS THE LOADINGS DUE TO THE OPGW WHICH CONTROLS THE DESIGN.
- DESIGN FOR HEIGHTS TO CONDUCTOR FROM 55' TO 115' IN 10' INCREMENTS (OVERALL HT 80' TO 140').
- PROVIDE SOCKET PILE DESIGN (DIAMETER, THICKNESS, AND OVERLAP) FOR EACH STRUCTURE.
- SEE DRAWING STD-4 FOR STRUCTURE FRAMING.

(SEE NOTE 8)

LOAD TREE 500KV 3-POLE

SLE3-DEPY-S 500 SK4 (35)

ENTERGY SERVICES, INC.

Transmission Line Design Standard

LOAD TREE, DEADEND, 35', SS, 55'-115'

STRUCTURE DRAWING & DETAIL

STD NO. SCALE: NONE

No. TFS243A0

PLOT 1=1 SH. 1 OF 1

0	11-21-07	CREATED	TWF	HSK	HSK
NDL	DATE:	REVISION	BY:	CHK:	APPR:
tfnc90		12/7/2007			

Appendix 2: High Voltage Overhead Transmission

Attachment 1: APPLICABLE STANDARD FRAMING AND ASSEMBLY DRAWINGS

LOADING TABLE *						
ITEMS		LOAD	CASE 1	CASE 2	CASE 3	CASE 4
INTACT	SW	T1	5994	5995	4556	1558
		V1	1887	4576	774	774
		L1	0	0	0	0
	COND	T2	34169	31280	29093	11258
		V2	14386	23110	6950	6950
		L2	0	0	0	0
DE ONE SIDE	SW	T1	2997	2998	2278	779
		V1	1289	3082	535	535
		L1	6460	7237	4480	1881
	COND	T2	17085	15640	14546	5629
		V2	9586	15448	4622	4622
		L2	37477	37758	28368	13589
WIND ON STRUCTURE		W	10	0	25.6	0
STRUCTURE WEIGHT		VS	TO BE DETERMINED BY T&B			
LINEMAN & EQUIP. WEIGHT		V4	500			
JUMPER INSULATOR WEIGHT		V3	215			

* V, T AND L IN POUNDS, W IN PSF (OLF INCLUDED)

WIRE DATA:

<p>SHIELDWIRE (2) 24 FIBER OPCW (GW2400 - 64mm2 / 528) DIA=0.528", WT=0.362 LBS/FT, RTS=18,432 LBS 1" RADIAL ICE, 15' F MAX TENSION 7833 LBS INITIAL EVERYDAY COND, 60F TENSION 2036 LBS INITIAL</p>	<p>PHASE CONDUCTOR (3) 954.0 KCMIL 45/7 STRAND ACSR "RAIL" (TRIPLE BUNDLED) DIA=1.165", WT=1.0750 LBS/FT, RTS=25,900 LBS 1" ICE, 15F MAX TENSION 13623 LBS INITIAL (SUB CONDUCT) EVERYDAY CONDITION, 60F TENSION 4903 LBS INITIAL (SUB CONDUCT)</p>
---	--

MECHANICAL LOADING CRITERIA:

CASE 1 - NESC MEDIUM: 4 PSF WIND ON WIRES AND STRUCTURE, 1/4" RADIAL ICE, 15' F. TRANSVERSE WIND OLF=2.50, LONGITUDINAL OLF=1.65; VERTICAL OLF=1.50.

CASE 2 - HEAVY ICE: 1" RADIAL ICE, NO WIND, 15' F. OLF=1.0

CASE 3 - HIGH WIND: 25.6 PSF WIND ON WIRES AND STRUCTURE, NO ICE, 60' F. OLF=1.00.

CASE 4 - EVERYDAY: NO WIND, NO ICE, 60' F. OLF=1.0

SPAN DATA:

WIND SPAN = 750 FT (INTACT) 375 FT (DE)
 WEIGHT SPAN = 2000 FT (INTACT) 1340 FT (DE)
 RULING SPAN = 1000 FT

NOTES:

- ALL LOADS ARE ULTIMATE LOADS AND INCLUDE OVERLOAD FACTORS PER MECHANICAL LOADING CRITERIA.
- FOR STRUCTURAL DESIGN, THE LONGITUDINAL (L), TRANSVERSE (T) AND VERTICAL (V) LOADS SHALL BE CONSIDERED TO ACT SIMULTANEOUSLY WITH WIND AND THE DEAD WEIGHT OF THE STRUCTURE.
- THE TRANSVERSE LOADS (T) INCLUDE WIND ON THE WIRES AND TRANSVERSE (TENSION) LOADS FROM THE LINE ANGLE AT THE STRUCTURE.
- V1 INCLUDES 50 LBS FOR SHIELDWIRE ASSEMBLY(S).
 V2 INCLUDES 500 LBS FOR INSULATOR ASSEMBLIES. (INTACT)
 V2 INCLUDES 300 LBS FOR INSULATOR ASSEMBLY. (DE)
- V4 (LINEMAN+EQUIPMENT) = 500 LBS AT ANY ONE LOCATION.
- DESIGN STRUCTURE FOR BOTH INTACT & DE ONE SIDE CONDITION.
- STRUCTURES TO BE DESIGNED TO SUPPORT ANY COMBINATION OF TWO SHIELD WIRES (FIBER OR 7#7) - ONE PER OUTSIDE LEG. ABOVE TABLE REFLECTS THE LOADINGS DUE TO THE OPCW WHICH CONTROLS THE DESIGN.
- DESIGN FOR HEIGHTS TO CONDUCTOR FROM 55' TO 115' IN 10' INCREMENTS (OVERALL HT 80' TO 140').
- PROVIDE SOCKET PILE DESIGN (DIAMETER, THICKNESS, AND OVERLAP) FOR EACH STRUCTURE.
- SEE DRAWING STD-4 FOR STRUCTURE FRAMING.

(SEE NOTE 8)

BASE PLATED STR.
 DRILLED PIER FOUNDATION

LOAD TREE 500KV 3-POLE
 SLE3-DEPY-S 500 SK4 (45)

ENTERGY SERVICES, INC.	
Transmission Line Design Standard LOAD TREE, DEADEND, 45', SS, 55'-115' STRUCTURE DRAWING & DETAIL	
STD NO.	SCALE: NONE
No. TFS244A0	
PLOT 1=1	SH. 1 OF 1

0	11-21-07	CREATED	TWF	HSK	HSK
NO.	DATE:	REVISION	BY:	CHK:	APPR:
		12/7/2007			

SLE3-DEPY-S 500; SK4 (45)

Appendix 2: High Voltage Overhead Transmission

Attachment 1: APPLICABLE STANDARD FRAMING AND ASSEMBLY DRAWINGS

LOADING TABLE *						
ITEMS		LOAD	CASE 1	CASE 2	CASE 3	CASE 4
INTACT	SW	T1	7100	7234	5323	1880
		V1	1887	4576	774	774
		L1	0	0	0	0
	COND	T2	40584	37742	33948	13584
		V2	14386	23110	6950	6950
		L2	0	0	0	0
DE ONE SIDE	SW	T1	3550	3617	2661	940
		V1	1289	3082	535	535
		L1	6203	6948	4301	1806
	COND	T2	20292	18871	16974	6792
		V2	9586	15448	4622	4622
		L2	35982	36251	27236	13047
WIND ON STRUCTURE		W	10	0	25.6	0
STRUCTURE WEIGHT		VS	TO BE DETERMINED BY T&B			
LINEMAN & EQUIP. WEIGHT		V4	500			
JUMPER INSULATOR WEIGHT		V3	215			

* V, T AND L IN POUNDS, W IN PSF (OLF INCLUDED)

WIRE DATA:

SHIELDWIRE
 (2) 24 FIBER OPGW (GW2400 - 84mm2 / 528)
 DIA=0.528", WT=0.362 LBS/FT, RTS=18,432 LBS
 1" RADIAL ICE, 15' F MAX TENSION 7833 LBS INITIAL
 EVERYDAY COND, 60' F TENSION 2036 LBS INITIAL

PHASE CONDUCTOR
 (3) 954.0 KCMIL 45/7 STRAND ACSR "RAIL" (TRIPLE BUNDLED)
 DIA=1.165", WT=1.0750 LBS/FT, RTS=25,900 LBS
 1" ICE, 15' F MAX TENSION 13623 LBS INITIAL (SUB CONDUCT)
 EVERYDAY CONDITION, 60' F TENSION 4903 LBS INITIAL (SUB CONDUCT)

MECHANICAL LOADING CRITERIA:

CASE 1 - NESC MEDIUM: 4 PSF WIND ON WIRES AND STRUCTURE, 1/4" RADIAL ICE, 15' F. TRANSVERSE WIND OLF=2.50, LONGITUDINAL OLF=1.65; VERTICAL OLF=1.50.

CASE 2 - HEAVY ICE: 1" RADIAL ICE, NO WIND, 15' F. OLF=1.0

CASE 3 - HIGH WIND: 25.6 PSF WIND ON WIRES AND STRUCTURE, NO ICE, 60' F. OLF=1.00.

CASE 4 - EVERYDAY: NO WIND, NO ICE, 60' F. OLF=1.0

SPAN DATA:

WIND SPAN = 750 FT (INTACT) 375 FT (DE)
 WEIGHT SPAN = 2000 FT (INTACT) 1340 FT (DE)
 RULING SPAN = 1000 FT

NOTES:

- ALL LOADS ARE ULTIMATE LOADS AND INCLUDE OVERLOAD FACTORS PER MECHANICAL LOADING CRITERIA.
- FOR STRUCTURAL DESIGN, THE LONGITUDINAL (L), TRANSVERSE (T) AND VERTICAL (V) LOADS SHALL BE CONSIDERED TO ACT SIMULTANEOUSLY WITH WIND AND THE DEAD WEIGHT OF THE STRUCTURE.
- THE TRANSVERSE LOADS (T) INCLUDE WIND ON THE WIRES AND TRANSVERSE (TENSION) LOADS FROM THE LINE ANGLE AT THE STRUCTURE.
- V1 INCLUDES 50 LBS FOR SHIELDWIRE ASSEMBLY(S). V2 INCLUDES 500 LBS FOR INSULATOR ASSEMBLIES. (INTACT) V2 INCLUDES 300 LBS FOR INSULATOR ASSEMBLY. (DE)
- V4 (LINEMAN+EQUIPMENT) = 500 LBS AT ANY ONE LOCATION.
- DESIGN STRUCTURE FOR BOTH INTACT & DE ONE SIDE CONDITION.
- STRUCTURES TO BE DESIGNED TO SUPPORT ANY COMBINATION OF TWO SHIELD WIRES (FIBER OR 7#7) - ONE PER OUTSIDE LEG. ABOVE TABLE REFLECTS THE LOADINGS DUE TO THE OPGW WHICH CONTROLS THE DESIGN.
- DESIGN FOR HEIGHTS TO CONDUCTOR FROM 55' TO 115' IN 10' INCREMENTS (OVERALL HT 80' TO 140').
- PROVIDE SOCKET PILE DESIGN (DIAMETER, THICKNESS, AND OVERLAP) FOR EACH STRUCTURE.
- SEE DRAWING STD-4 FOR STRUCTURE FRAMING.

(SEE NOTE B)

LOAD TREE 500KV 3-POLE

SLE3-DEPY-S 500 SK4 (55)

ENERGY SERVICES, INC.

Transmission Line Design Standard
LOAD TREE, DEADEND, 55', 55', 55'-115'
STRUCTURE DRAWING & DETAIL

STD NO. _____ SCALE: NONE

No. TFS245A0

PLOT 1=1 SH. 1 OF 1

SLE3-DEPY-S 500; SK4 (55)

0	11-21-07	CREATED	TWF	HSK	HSK
ND.	DATE	REVISION	BY:	CHK:	APPR:
	tfinc90	12/7/2007			

Appendix 2: High Voltage Overhead Transmission

Attachment 1: APPLICABLE STANDARD FRAMING AND ASSEMBLY DRAWINGS

LOADING TABLE *						
ITEMS		LOAD	CASE 1	CASE 2	CASE 3	CASE 4
INTACT	SW	T1	8157	8417	6056	2188
		V1	1887	4576	774	774
		L1	0	0	0	0
	COND	T2	46713	43918	38588	15806
		V2	14386	23110	6950	6950
		L2	0	0	0	0
DE ONE SIDE	SW	T1	4078	4209	3028	1094
		V1	1289	3082	535	535
		L1	5898	6606	4090	1717
	COND	T2	23357	21959	19294	7903
		V2	9586	15448	4622	4622
		L2	34212	34469	25896	12405
WIND ON STRUCTURE		W	10	0	25.6	0
STRUCTURE WEIGHT		VS	TO BE DETERMINED BY T&B			
LINEMAN & EQUIP. WEIGHT		V4	500			
JUMPER INSULATOR WEIGHT		V3	215			

* V, T AND L IN POUNDS, W IN PSF (OLF INCLUDED)

SHIELDWIRE
 (2) 24 FIBER OPGW (GW2400 - 64mm² / 528)
 DIA=0.528", WT=0.362 LBS/FT, RTS=18,432 LBS
 1" RADIAL ICE, 15' F MAX TENSION 7833 LBS INITIAL
 EVERYDAY COND, 60' F TENSION 2036 LBS INITIAL

PHASE CONDUCTOR
 (3) 954.0 KCMIL 45/7 STRAND ACSR "RAIL" (TRIPLE BUNDLED)
 DIA=1.165", WT=1.0750 LBS/FT, RTS=25,900 LBS
 1" ICE, 15' F MAX TENSION 13623 LBS INITIAL (SUB CONDUCT)
 EVERYDAY CONDITION, 60' F TENSION 4903 LBS INITIAL (SUB CONDUCT)

WIRE DATA:

MECHANICAL LOADING CRITERIA:

CASE 1 - NESC MEDIUM: 4 PSF WIND ON WIRES AND STRUCTURE, 1/4" RADIAL ICE, 15' F, TRANSVERSE WIND OLF=2.50, LONGITUDINAL OLF=1.65; VERTICAL OLF=1.50.

CASE 2 - HEAVY ICE: 1" RADIAL ICE, NO WIND, 15' F, OLF=1.0

CASE 3 - HIGH WIND: 25.6 PSF WIND ON WIRES AND STRUCTURE, NO ICE, 60' F, OLF=1.00.

CASE 4 - EVERYDAY: NO WIND, NO ICE, 60' F, OLF=1.0

SPAN DATA:

WIND SPAN = 750 FT (INTACT) 375 FT (DE)
 WEIGHT SPAN = 2000 FT (INTACT) 1340 FT (DE)
 RULING SPAN = 1000 FT

NOTES:

- ALL LOADS ARE ULTIMATE LOADS AND INCLUDE OVERLOAD FACTORS PER MECHANICAL LOADING CRITERIA.
- FOR STRUCTURAL DESIGN, THE LONGITUDINAL (L), TRANSVERSE (T) AND VERTICAL (V) LOADS SHALL BE CONSIDERED TO ACT SIMULTANEOUSLY WITH WIND AND THE DEAD WEIGHT OF THE STRUCTURE.
- THE TRANSVERSE LOADS (T) INCLUDE WIND ON THE WIRES AND TRANSVERSE (TENSION) LOADS FROM THE LINE ANGLE AT THE STRUCTURE.
- V1 INCLUDES 50 LBS FOR SHIELDWIRE ASSEMBLY(S). V2 INCLUDES 500 LBS FOR INSULATOR ASSEMBLIES. (INTACT) V2 INCLUDES 300 LBS FOR INSULATOR ASSEMBLY. (DE)
- V4 (LINEMAN+EQUIPMENT) = 500 LBS AT ANY ONE LOCATION.
- DESIGN STRUCTURE FOR BOTH INTACT & DE ONE SIDE CONDITION.
- STRUCTURES TO BE DESIGNED TO SUPPORT ANY COMBINATION OF TWO SHIELD WIRES (FIBER OR 7#) - ONE PER OUTSIDE LEG. ABOVE TABLE REFLECTS THE LOADINGS DUE TO THE OPGW WHICH CONTROLS THE DESIGN.
- DESIGN FOR HEIGHTS TO CONDUCTOR FROM 55' TO 115' IN 10' INCREMENTS (OVERALL HT 80' TO 140').
- PROVIDE SOCKET PILE DESIGN (DIAMETER, THICKNESS, AND OVERLAP) FOR EACH STRUCTURE.
- SEE DRAWING STD-4 FOR STRUCTURE FRAMING.

LOAD TREE 500KV 3-POLE

SLE3-DEPY-S 500 SK4 (65)

ENTERGY SERVICES, INC.

Transmission Line Design Standard
LOAD TREE, DEADEND, 65', SS, 55'-115'
STRUCTURE DRAWING & DETAIL

STD NO. _____ SCALE: NONE

No. TFS246A0

PLOT 1=1 SH.1 OF 1

0	11-21-07	CREATED	TWF	HSK	HSK
NO.	DATE	REVISION	BY	CHK	APPR
		12/7/2007			

SLE3-DEPY-S 500; SK4 (65)

Appendix 2: High Voltage Overhead Transmission

Attachment 1: APPLICABLE STANDARD FRAMING AND ASSEMBLY DRAWINGS

LOADING TABLE *						
ITEMS		LOAD	CASE 1	CASE 2	CASE 3	CASE 4
INTACT	SW	T1	8664	8986	6407	2336
		V1	1887	4576	774	774
		L1	0	0	0	0
	COND	T2	49656	46883	40815	16873
		V2	14386	23110	6950	6950
		L2	0	0	0	0
DE ONE SIDE	SW	T1	4332	4493	3204	1168
		V1	1289	3082	535	535
		L1	5728	6416	3972	1668
	COND	T2	24828	23441	20408	8437
		V2	9586	15448	4622	4622
		L2	33229	33478	25152	12049
WIND ON STRUCTURE		W	10	0	25.6	0
STRUCTURE WEIGHT		VS	TO BE DETERMINED BY T&B			
LINEMAN & EQUIP. WEIGHT		V3	500			

* V, T AND L IN POUNDS, W IN PSF (OLF INCLUDED)

SHIELDWIRE
(2) 24 FIBER OPGW (GW2400 - 64mm2 / 528)
DIA=0.528", WT=0.362 LBS/FT, RTS=18,432 LBS
1" RADIAL ICE, 15' F MAX TENSION 7833 LBS INITIAL
EVERYDAY COND, 60' F TENSION 2036 LBS INITIAL

PHASE CONDUCTOR
(3) 954.0 KCMIL 45/7 STRAND ACSR "RAIL" (TRIPLE BUNDLED)
DIA=1.165", WT=1.0750 LBS/FT, RTS=25,900 LBS
1" ICE, 15' F MAX TENSION 13623 LBS INITIAL (SUB CONDUCT)
EVERYDAY CONDITION, 60' F TENSION 4903 LBS INITIAL (SUB CONDUCT)

MECHANICAL LOADING CRITERIA:

CASE 1 - NESC MEDIUM: 4 PSF WIND ON WIRES AND STRUCTURE, 1/4" RADIAL ICE, 15' F. TRANSVERSE WIND OLF=2.50, LONGITUDINAL OLF=1.65; VERTICAL OLF=1.50.

CASE 2 - HEAVY ICE: 1" RADIAL ICE, NO WIND, 15' F. OLF=1.0

CASE 3 - HIGH WIND: 25.6 PSF WIND ON WIRES AND STRUCTURE, NO ICE, 60' F. OLF=1.00.

CASE 4 - EVERYDAY: NO WIND, NO ICE, 60' F. OLF=1.0

SPAN DATA:

WIND SPAN = 750 FT (INTACT) 375 FT (DE)
WEIGHT SPAN = 2000 FT (INTACT) 1340 FT (DE)
RULING SPAN = 1000 FT

NOTES:

- ALL LOADS ARE ULTIMATE LOADS AND INCLUDE OVERLOAD FACTORS PER MECHANICAL LOADING CRITERIA.
- FOR STRUCTURAL DESIGN, THE LONGITUDINAL (L), TRANSVERSE (T) AND VERTICAL (V) LOADS SHALL BE CONSIDERED TO ACT SIMULTANEOUSLY WITH WIND AND THE DEAD WEIGHT OF THE STRUCTURE.
- THE TRANSVERSE LOADS (T) INCLUDE WIND ON THE WIRES AND TRANSVERSE (TENSION) LOADS FROM THE LINE ANGLE AT THE STRUCTURE.
- V1 INCLUDES 50 LBS FOR SHIELDWIRE ASSEMBLY(S).
V2 INCLUDES 500 LBS FOR INSULATOR ASSEMBLIES. (INTACT)
V2 INCLUDES 300 LBS FOR INSULATOR ASSEMBLY. (DE)
- V3 (LINEMAN+EQUIPMENT) = 500 LBS AT ANY ONE LOCATION.
- DESIGN STRUCTURE FOR BOTH INTACT & DE ONE SIDE CONDITION.
- STRUCTURES TO BE DESIGNED TO SUPPORT ANY COMBINATION OF TWO SHIELD WIRES (FIBER OR 7/7) - ONE PER OUTSIDE LEG. ABOVE TABLE REFLECTS THE LOADINGS DUE TO THE OPGW WHICH CONTROLS THE DESIGN.
- DESIGN FOR HEIGHTS TO CONDUCTOR FROM 55' TO 115' IN 10' INCREMENTS (OVERALL HT 80' TO 140').
- PROVIDE SOCKET PILE DESIGN (DIAMETER, THICKNESS, AND OVERLAP) FOR EACH STRUCTURE.
- SEE DRAWING STD-5 FOR STRUCTURE FRAMING.

LOAD TREE 500KV 3-POLE
SLE3-DEPY-S 500 SK5 (70)

ENTERGY SERVICES, INC.		Transmission Line Design Standard	
LOAD TREE, DEADEND, 70', SS, 55'-115'		STRUCTURE DRAWING & DETAIL	
STD NO.	SCALE: NONE	No. TFS247A0	
0	11-21-07	CREATED	TWF HSK HSK
NO.	DATE:	REVISION	BY: CHK: APPR:
tline90		12/7/2007	

PLOT 1=1 SH. 1 OF 1
SLE3-DEPY-S 500; SK5 (70)

Appendix 2: High Voltage Overhead Transmission

Attachment 1: APPLICABLE STANDARD FRAMING AND ASSEMBLY DRAWINGS

LOADING TABLE *						
ITEMS		LOAD	CASE 1	CASE 2	CASE 3	CASE 4
INTACT	SW	T1	9632	10070	7079	2617
		V1	1887	4576	774	774
		L1	0	0	0	0
	COND	T2	55272	52540	45066	18910
		V2	14386	23110	6950	6950
		L2	0	0	0	0
DE ONE SIDE	SW	T1	4816	5035	3539	1309
		V1	1289	3082	535	535
		L1	5357	6000	3715	1560
	COND	T2	27636	26270	22533	9455
		V2	9586	15448	4622	4622
		L2	31075	31307	23521	11286
WIND ON STRUCTURE		W	10	0	25.6	0
STRUCTURE WEIGHT		VS	TO BE DETERMINED BY T&B			
LINEMAN & EQUIP. WEIGHT		V3	500			

* V, T AND L IN POUNDS, W IN PSF (OLF INCLUDED)

WIRE DATA:

SHIELDWIRE
 (2) 24 FIBER OPGW (GW2400 - 64mm² / 528)
 DIA=0.528", WT=0.362 LBS/FT, RTS=18,432 LBS
 1" RADIAL ICE, 15' F MAX TENSION 7833 LBS INITIAL
 EVERYDAY COND, 60F TENSION 2036 LBS INITIAL

PHASE CONDUCTOR
 (3) 954.0 KCMIL 45/7 STRAND ACSR "RAIL" (TRIPLE BUNDLED)
 DIA=1.165", WT=1.0750 LBS/FT, RTS=25,900 LBS
 1" ICE, 15F MAX TENSION 13623 LBS INITIAL (SUB CONDUCT)
 EVERYDAY CONDITION, 60F TENSION 4903 LBS INITIAL (SUB CONDUCT)

MECHANICAL LOADING CRITERIA:

CASE 1 - NESC MEDIUM: 4 PSF WIND ON WIRES AND STRUCTURE, 1/4" RADIAL ICE, 15' F. TRANSVERSE WIND OLF=2.50, LONGITUDINAL OLF=1.65; VERTICAL OLF=1.50.

CASE 2 - HEAVY ICE: 1" RADIAL ICE, NO WIND, 15' F. OLF=1.0

CASE 3 - HIGH WIND: 25.6 PSF WIND ON WIRES AND STRUCTURE, NO ICE, 60' F. OLF=1.00.

CASE 4 - EVERYDAY: NO WIND, NO ICE, 60' F. OLF=1.0

SPAN DATA:
 WIND SPAN = 750 FT (INTACT) 375 FT (DE)
 WEIGHT SPAN = 2000 FT (INTACT) 1340 FT (DE)
 RULING SPAN = 1000 FT

NOTES:

- ALL LOADS ARE ULTIMATE LOADS AND INCLUDE OVERLOAD FACTORS PER MECHANICAL LOADING CRITERIA.
- FOR STRUCTURAL DESIGN, THE LONGITUDINAL (L), TRANSVERSE (T) AND VERTICAL (V) LOADS SHALL BE CONSIDERED TO ACT SIMULTANEOUSLY WITH WIND AND THE DEAD WEIGHT OF THE STRUCTURE.
- THE TRANSVERSE LOADS (T) INCLUDE WIND ON THE WIRES AND TRANSVERSE (TENSION) LOADS FROM THE LINE ANGLE AT THE STRUCTURE.
- V1 INCLUDES 50 LBS FOR SHIELDWIRE ASSEMBLY(S). V2 INCLUDES 500 LBS FOR INSULATOR ASSEMBLIES. (INTACT) V2 INCLUDES 300 LBS FOR INSULATOR ASSEMBLY. (DE)
- V3 (LINEMAN+EQUIPMENT) = 500 LBS AT ANY ONE LOCATION.
- DESIGN STRUCTURE FOR BOTH INTACT & DE ONE SIDE CONDITION.
- STRUCTURES TO BE DESIGNED TO SUPPORT ANY COMBINATION OF TWO SHIELD WIRES (FIBER OR 7#7) - ONE PER OUTSIDE LEG. ABOVE TABLE REFLECTS THE LOADINGS DUE TO THE OPGW WHICH CONTROLS THE DESIGN.
- DESIGN FOR HEIGHTS TO CONDUCTOR FROM 55' TO 115' IN 10' INCREMENTS (OVERALL HT 80' TO 140').
- PROVIDE SOCKET PILE DESIGN (DIAMETER, THICKNESS, AND OVERLAP) FOR EACH STRUCTURE.
- SEE DRAWING STD-5 FOR STRUCTURE FRAMING.

(SEE NOTE 6)

BASE PLATED STR.
DRILLED PIER FOUNDATION

LOAD TREE 500KV 3-POLE
 SLE3-DEPY-S 500 SK5 (80)

ENTERGY SERVICES, INC.	
Transmission Line Design Standard LOAD TREE, DEADEND, 80', SS, 55'-115' STRUCTURE DRAWING & DETAIL	
STD NO.	SCALE: NONE
No. TFS248A0	
PLOT 1=1	SH.1 OF 1
SLE3-DEPY-S 500; SK5 (80)	

0	11-21-07	CREATED	TWF	HSK	HSK
ND	DATE	REVISION	BY	CHK	APPR
		12/7/2007			

Appendix 2: High Voltage Overhead Transmission

Attachment 1: APPLICABLE STANDARD FRAMING AND ASSEMBLY DRAWINGS

LOADING TABLE *						
ITEMS		LOAD	CASE 1	CASE 2	CASE 3	CASE 4
INTACT	SW	T1	10532	11078	7702	2879
		V1	1887	4576	774	774
		L1	0	0	0	0
	COND	T2	60490	57797	49015	20802
		V2	14386	23110	6950	6950
		L2	0	0	0	0
DE ONE SIDE	SW	T1	5266	5539	3851	1440
		V1	1289	3082	535	535
		L1	4945	5539	3429	1440
	COND	T2	30245	28899	24508	10401
		V2	9586	15448	4622	4622
		L2	28684	28899	21712	10401
WIND ON STRUCTURE		W	10	0	25.6	0
STRUCTURE WEIGHT		VS	TO BE DETERMINED BY T&B			
LINEMAN & EQUIP. WEIGHT		V3	500			

* V, T AND L IN POUNDS, W IN PSF (OLF INCLUDED)

WIRE DATA:

SHIELDWIRE

(2) 24 FIBER OPGW (GW2400 - 64mm² / 528)
DIA=0.528", WT=0.362 LBS/FT, RTS=18,432 LBS
1" RADIAL ICE, 15' F MAX TENSION 7833 LBS INITIAL
EVERYDAY COND, 60' TENSION 2036 LBS INITIAL

PHASE CONDUCTOR

(3) 954.0 KCMIL 45/7 STRAND ACSR "RAIL" (TRIPLE BUNDLED)
DIA=1.165", WT=1.0750 LBS/FT, RTS=25,900 LBS
1" ICE, 15' F MAX TENSION 13623 LBS INITIAL (SUB CONDUCT)
EVERYDAY CONDITION, 60' TENSION 4903 LBS INITIAL (SUB CONDUCT)

MECHANICAL LOADING CRITERIA:

- CASE 1 - NESC MEDIUM: 4 PSF WIND ON WIRES AND STRUCTURE, 1/4" RADIAL ICE, 15' F. TRANSVERSE WIND OLF=2.50, LONGITUDINAL OLF=1.65; VERTICAL OLF=1.50.
- CASE 2 - HEAVY ICE: 1" RADIAL ICE, NO WIND, 15' F. OLF=1.0
- CASE 3 - HIGH WIND: 25.6 PSF WIND ON WIRES AND STRUCTURE, NO ICE, 60' F, OLF=1.00.
- CASE 4 - EVERYDAY: NO WIND, NO ICE, 60' F. OLF=1.0

SPAN DATA:

WIND SPAN = 750 FT (INTACT) 375 FT (DE)
WEIGHT SPAN = 2000 FT (INTACT) 1340 FT (DE)
RULING SPAN = 1000 FT

NOTES:

- ALL LOADS ARE ULTIMATE LOADS AND INCLUDE OVERLOAD FACTORS PER MECHANICAL LOADING CRITERIA.
- FOR STRUCTURAL DESIGN, THE LONGITUDINAL (L), TRANSVERSE (T) AND VERTICAL (V) LOADS SHALL BE CONSIDERED TO ACT SIMULTANEOUSLY WITH WIND AND THE DEAD WEIGHT OF THE STRUCTURE.
- THE TRANSVERSE LOADS (T) INCLUDE WIND ON THE WIRES AND TRANSVERSE (TENSION) LOADS FROM THE LINE ANGLE AT THE STRUCTURE.
- V1 INCLUDES 50 LBS FOR SHIELDWIRE ASSEMBLY(S). V2 INCLUDES 500 LBS FOR INSULATOR ASSEMBLIES. (INTACT) V2 INCLUDES 300 LBS FOR INSULATOR ASSEMBLY. (DE)
- V3 (LINEMAN+EQUIPMENT) = 500 LBS AT ANY ONE LOCATION.
- DESIGN STRUCTURE FOR BOTH INTACT & DE ONE SIDE CONDITION.
- STRUCTURES TO BE DESIGNED TO SUPPORT ANY COMBINATION OF TWO SHIELD WIRES (FIBER OR 7#7) - ONE PER OUTSIDE LEG. ABOVE TABLE REFLECTS THE LOADINGS DUE TO THE OPGW WHICH CONTROLS THE DESIGN.
- DESIGN FOR HEIGHTS TO CONDUCTOR FROM 55' TO 115' IN 10' INCREMENTS (OVERALL HT 80' TO 140').
- PROVIDE SOCKET PILE DESIGN (DIAMETER, THICKNESS, AND OVERLAP) FOR EACH STRUCTURE.
- SEE DRAWING STD-5 FOR STRUCTURE FRAMING.

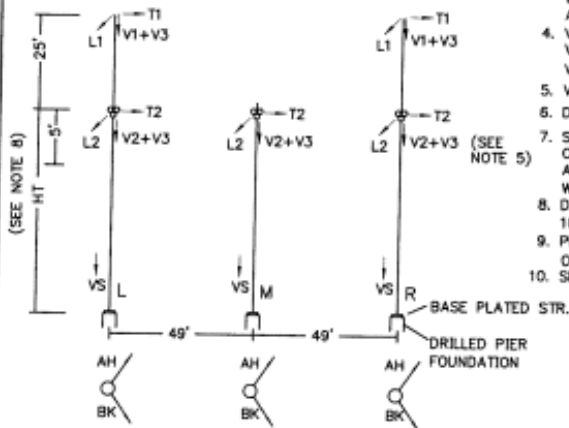

LOAD TREE 500KV 3-POLE
SLE3-DEPY-S 500 SK5 (90)

ENTERGY SERVICES, INC.	
Transmission Line Design Standard	
LOAD TREE, DEADEND, 90°, SS, 55'-115'	
STRUCTURE DRAWING & DETAIL	
STD NO.	SCALE: NONE
No. TFS249A0	
PLOT 1=1 SH. 1 OF 1	

0	11-21-07	CREATED	TWF	HSK	HSK
ND	DATE:	REVISION	BY:	CHK:	APPR:
	tfinc90	12/7/2007			

Appendix 2: High Voltage Overhead Transmission

Attachment 1: APPLICABLE STANDARD FRAMING AND ASSEMBLY DRAWINGS

LOADING TABLE *						
ITEMS		LOAD	CASE 1	CASE 2	CASE 3	CASE 4
INTACT	SW	T1	11356	12001	8274	3119
		V1	1887	4576	774	774
		L1	0	0	0	0
	COND	T2	65271	62615	52635	22535
		V2	14386	23110	6950	6950
		L2	0	0	0	0
DE ONE SIDE	SW	T1	5678	6000	4137	1560
		V1	1289	3082	535	535
		L1	4495	5035	3117	1309
	COND	T2	32636	31307	26317	11268
		V2	9586	15448	4622	4622
		L2	26075	26270	19737	9455
WIND ON STRUCTURE		W	10	0	25.6	0
STRUCTURE WEIGHT		VS	TO BE DETERMINED BY T&B			
LINEMAN & EQUIP. WEIGHT		V3	500			

* V, T AND L IN POUNDS, W IN PSF (OLF INCLUDED)

WIRE DATA:

SHIELDWIRE
(2) 24 FIBER OPGW (GW2400 - 64mm² / 528)
DIA=0.528", WT=0.362 LBS/FT, RTS=18,432 LBS
1" RADIAL ICE, 15' F MAX TENSION 7833 LBS INITIAL
EVERYDAY COND, 60°F TENSION 2036 LBS INITIAL

PHASE CONDUCTOR
(3) 954.0 KCMIL 45/7 STRAND ACSR "RAIL" (TRIPLE BUNDLED)
DIA=1.165", WT=1.0750 LBS/FT, RTS=25,900 LBS
1" ICE, 15F MAX TENSION 13623 LBS INITIAL (SUB CONDUCT)
EVERYDAY CONDITION, 60°F TENSION 4903 LBS INITIAL (SUB CONDUCT)

MECHANICAL LOADING CRITERIA:

CASE 1 - NESC MEDIUM: 4 PSF WIND ON WIRES AND STRUCTURE, 1/4" RADIAL ICE, 15' F. TRANSVERSE WIND OLF=2.50, LONGITUDINAL OLF=1.65; VERTICAL OLF=1.50.

CASE 2 - HEAVY ICE: 1" RADIAL ICE, NO WIND, 15' F. OLF=1.0

CASE 3 - HIGH WIND: 25.6 PSF WIND ON WIRES AND STRUCTURE, NO ICE, 60' F. OLF=1.00.

CASE 4 - EVERYDAY: NO WIND, NO ICE, 60' F. OLF=1.0

SPAN DATA:
WIND SPAN = 750 FT (INTACT) 375 FT (DE)
WEIGHT SPAN = 2000 FT (INTACT) 1340 FT (DE)
RULING SPAN = 1000 FT

NOTES:

- ALL LOADS ARE ULTIMATE LOADS AND INCLUDE OVERLOAD FACTORS PER MECHANICAL LOADING CRITERIA.
- FOR STRUCTURAL DESIGN, THE LONGITUDINAL (L), TRANSVERSE (T) AND VERTICAL (V) LOADS SHALL BE CONSIDERED TO ACT SIMULTANEOUSLY WITH WIND AND THE DEAD WEIGHT OF THE STRUCTURE.
- THE TRANSVERSE LOADS (T) INCLUDE WIND ON THE WIRES AND TRANSVERSE (TENSION) LOADS FROM THE LINE ANGLE AT THE STRUCTURE.
- V1 INCLUDES 50 LBS FOR SHIELDWIRE ASSEMBLY(S).
V2 INCLUDES 500 LBS FOR INSULATOR ASSEMBLIES. (INTACT)
V2 INCLUDES 300 LBS FOR INSULATOR ASSEMBLY. (DE)
- V3 (LINEMAN+EQUIPMENT) = 500 LBS AT ANY ONE LOCATION.
- DESIGN STRUCTURE FOR BOTH INTACT & DE ONE SIDE CONDITION.
- STRUCTURES TO BE DESIGNED TO SUPPORT ANY COMBINATION OF TWO SHIELD WIRES (FIBER OR 7#7) - ONE PER OUTSIDE LEG. ABOVE TABLE REFLECTS THE LOADINGS DUE TO THE OPGW WHICH CONTROLS THE DESIGN.
- DESIGN FOR HEIGHTS TO CONDUCTOR FROM 55' TO 115' IN 10' INCREMENTS (OVERALL HT 80' TO 140').
- PROVIDE SOCKET PILE DESIGN (DIAMETER, THICKNESS, AND OVERLAP) FOR EACH STRUCTURE.
- SEE DRAWING STD-5 FOR STRUCTURE FRAMING.

LOAD TREE 500KV 3-POLE
SLE3-DEPY-S 500 SK5 (100)

ENERGY SERVICES, INC.
Transmission Line Design Standard
LOAD TREE, DEADEND, 100', SS, 55'-115'
STRUCTURE DRAWING & DETAIL

STD NO. SCALE: NONE
No. TFS250A0
PLOT 1=1 SH. 1 OF 1

11-21-07 CREATED
DATE: REVISION
TWF HSK HSK
BY: CHK: APPR:

tfinc90 12/7/2007 SLE3-DEPY-S 500; SK5 (100)

Appendix 2: High Voltage Overhead Transmission

Attachment 1: APPLICABLE STANDARD FRAMING AND ASSEMBLY DRAWINGS

TEMP:\AM-Work\willi2\IM-LITAPETSP047.D-TDdocs\S-Template\ESI\STANDARD\SDS\Transmission\AMISC\TMD207A1.DWG. 5/20/2010 5:26:50 PM. ewilliz

BILL OF MATERIALS			
VARIABLE BOLT ASSY, DOUBLE POLY POST FOR CONCRETE WITH GROUNDING			
ITEM	QTY.	STOCK NO.	DESCRIPTION
1	1	EN000171	NUT, SQUARE, STL, GALV, ANSI-C135.1, 7/8" DIA, 9 THD
2	1	EN000358	CLIP, BONDING, 7/8", STL, GALV, FOR GROUNDING TO 7/8" BOLT
3	1	EN000362	WIRE, COPPERWELD, #4 (.1158 lbs/ft)
4	8	EN000426	NUT, LOCK, SQUARE, STL, GALV. ANSI-C135.1, 7/8" DIA. 9 THD
5	1	EN000360	CONNECTOR, #4 COPPER CRIMPIT
6	2	LS909XX	BOLT, DOUBLE ARMING, 7/8"xVARIABLE LENGTH, GALV, w/4 SQ NUTS
7	8	EN005685	WASHER, FLAT ROUND, 2" STEEL, GALV, FOR 7/8" BOLT

- 1) All Double Arming Bolts shall be trimmed to avoid conflict with guys, grounding, conductors, etc. and painted with galvanized paint.
- 2) Grounding Lug location may be above or below assembly depending on pole tank ground location.

BLT-2P-C	
ENTERGY STANDARD DWG.	
DESIGN APPROVAL	STANDARDS APPROVAL
SIGNED _____ / DATE _____	SIGNED _____ / DATE _____
BOLT ASSY (CONCRETE) DOUBLE POLYMER POST INS.	
APPROVED BY: EJG	DATE: 01-27-97
CHECKED BY: JWS	SCALE: NONE
DRAWN BY: ECSI	ESI NO. TMD207A1
No. BLT2PC	
PLOT 1=8 SH. 1 OF 1	

1	5-28-03	REV. DIM., CHANGE WASHER FROM SQ. TO FLAT ROUND	ITRON	
NO.	DATE:	REVISION	BY:	APPR:

Appendix 2: High Voltage Overhead Transmission

Attachment 1: APPLICABLE STANDARD FRAMING AND ASSEMBLY DRAWINGS

BILL OF MATERIALS																																			
VARIABLE BOLT ASSY, DOUBLE POLY POST FOR STEEL																																			
ITEM	QTY.	STOCK NO.	DESCRIPTION																																
1	8	EN000426	NUT, LOCK, SQUARE, STL, GALV, ANSI-C135.1, 7/8" DIA, 9 THD																																
2	8	EN005685	WASHER, FLAT ROUND, 2" STEEL, GALV, FOR 7/8" BOLT																																
3	2	LS909XX	BOLT, DOUBLE ARMING, 7/8"xVARIABLE LENGTH, GALV, w/4 SQ NUTS																																
<p>1) All Double Arming Bolts shall be trimmed to avoid conflict with guys, grounding, conductors, etc. and painted with galvanized paint.</p>																																			
<table border="1" style="width: 100%; border-collapse: collapse;"> <tr> <td style="width: 10%;">1</td> <td style="width: 15%;">5-28-03</td> <td style="width: 40%;">CHANGE WASHER, DIM.</td> <td style="width: 10%;">ITRON</td> <td style="width: 25%;"></td> </tr> <tr> <td>NO.</td> <td>DATE:</td> <td>REVISION</td> <td>BY:</td> <td>APPR:</td> </tr> </table>		1	5-28-03	CHANGE WASHER, DIM.	ITRON		NO.	DATE:	REVISION	BY:	APPR:	<table border="1" style="width: 100%; border-collapse: collapse;"> <tr> <td colspan="2" style="text-align: center;">BLT-2P-S</td> </tr> <tr> <td colspan="2" style="text-align: center;">ENTERGY STANDARD DWG.</td> </tr> <tr> <td style="width: 50%;">DESIGN APPROVAL</td> <td style="width: 50%;">STANDARDS APPROVAL</td> </tr> <tr> <td>SIGNED _____ / DATE _____</td> <td>SIGNED _____ / DATE _____</td> </tr> <tr> <td colspan="2" style="text-align: center;">BOLT ASSY (STEEL) DOUBLE POLYMER POST INS.</td> </tr> <tr> <td>APPROVED BY:</td> <td>DATE: 2-12-96</td> </tr> <tr> <td>CHECKED BY:</td> <td>SCALE: NONE</td> </tr> <tr> <td>DRAWN BY: ECSI</td> <td>ESI NO. TMD208A1</td> </tr> <tr> <td colspan="2" style="text-align: center;">No. BLT2PS</td> </tr> <tr> <td colspan="2" style="text-align: center;"> </td> </tr> <tr> <td>PLOT 1=8</td> <td>SH. 1 OF 1</td> </tr> </table>		BLT-2P-S		ENTERGY STANDARD DWG.		DESIGN APPROVAL	STANDARDS APPROVAL	SIGNED _____ / DATE _____	SIGNED _____ / DATE _____	BOLT ASSY (STEEL) DOUBLE POLYMER POST INS.		APPROVED BY:	DATE: 2-12-96	CHECKED BY:	SCALE: NONE	DRAWN BY: ECSI	ESI NO. TMD208A1	No. BLT2PS				PLOT 1=8	SH. 1 OF 1
1	5-28-03	CHANGE WASHER, DIM.	ITRON																																
NO.	DATE:	REVISION	BY:	APPR:																															
BLT-2P-S																																			
ENTERGY STANDARD DWG.																																			
DESIGN APPROVAL	STANDARDS APPROVAL																																		
SIGNED _____ / DATE _____	SIGNED _____ / DATE _____																																		
BOLT ASSY (STEEL) DOUBLE POLYMER POST INS.																																			
APPROVED BY:	DATE: 2-12-96																																		
CHECKED BY:	SCALE: NONE																																		
DRAWN BY: ECSI	ESI NO. TMD208A1																																		
No. BLT2PS																																			
PLOT 1=8	SH. 1 OF 1																																		

TEMP\IAM-Work\ewillii2\IM-LITAPETSP047.D-TDdocs-S-Template\ESI\STANDARDSD\Transmission\AMISC\TMD208A1.DWG. 5/20/2010 5:31:01 PM. ewillii2

Appendix 2: High Voltage Overhead Transmission

Attachment 1: APPLICABLE STANDARD FRAMING AND ASSEMBLY DRAWINGS

BILL OF MATERIALS			
VARIABLE BOLT ASSY, SINGLE POLY POST FOR CONCRETE WITH GROUNDING			
ITEM	QTY.	STOCK NO.	DESCRIPTION
1	1	EN000171	NUT, SQUARE, STL, GALV, ANSI-C135.1, 7/8" DIA, 9 THD
2	1	EN000358	CLIP, BONDING, 7/8", STL, GALV, FOR GROUNDING TO 7/8" BOLT
3	1	EN000362	WIRE, COPPERWELD, #4 (.1158 lbs/ft)
4	6	EN000426	NUT, LOCK, SQUARE, STL, GALV, ANSI-C135.1, 7/8" DIA, 9 THD
5	2	EN012280	WASHER, SQUARE CURVED, STL, GALV, 7/8" BOLT, 3"x3"x1/4"
6	1	EN000360	CONNECTOR, #4 COPPER CRIMPIT
7	2	LS909XX	BOLT, DOUBLE ARMING, 7/8"xVARIABLE LENGTH, GALV, w/4 SQ NUTS
8	4	EN005685	WASHER, FLAT ROUND, 2" STEEL, GALV, FOR 7/8" BOLT

1) All Double Arming Bolts shall be trimmed to avoid conflict with guys, grounding, conductors, etc. and painted with galvanized paint.

2) Grounding Lug location may be above or below assembly depending on pole tank ground location.

BLT-P-C

ENTERGY STANDARD DWG.

DESIGN APPROVAL	STANDARDS APPROVAL
SIGNED _____ / DATE _____	SIGNED _____ / DATE _____

BOLT ASSY (CONCRETE)
SINGLE POLYMER POST INS.

APPROVED BY: EJC	DATE: 01-27-97
CHECKED BY: JWS	SCALE: NONE
DRAWN BY: ECSI	ESI NO. TMD211A1

No. BLTPC	
PLOT 1=8	SH. 1 OF 1

1	5-30-03	CHANGE WASHER, DIM.	ITRON	
NO.	DATE:	REVISION	BY:	APPR:

TEMP:\AM-Work\williiz\IM-LITAPETSP047.D-TDdocs-S-Template\ESI\STANDARD\STransmission\AMISC\TMD211A1.DWG. 5/20/2010 5:21:50 PM. ewilliiz

Appendix 2: High Voltage Overhead Transmission

Attachment 1: APPLICABLE STANDARD FRAMING AND ASSEMBLY DRAWINGS

BILL OF MATERIALS			
OHGW DEADEND			
ITEM	QTY.	STOCK NO.	DESCRIPTION
1	2	EN000492	SHACKLE, ANCHOR, 40K ULT, 3/4" PIN DIA, 2-3/4" LONG
2	1	LS9004XX	TERMINAL CONNECTOR, 15 DEG, FOR VARIABLE SIZE WIRE
3	1	LS9005XX	DEADEND, ALUMINUM COMPRESSION BODY, SINGLE TONGUE, VARIABLE WIRE SIZE
4	-	LS5012XX	CONNECTOR, AMPACT, SEE GND ASSEMBLY DRAWING FOR MATERIAL
ALTERNATE FOR BOLTED ASSEMBLY			
ITEM	QTY.	STOCK NO.	DESCRIPTION
1	2	EN000492	SHACKLE, ANCHOR, 40K ULT, 3/4" PIN DIA, 2-3/4" LONG
4	-	LS5012XX	CONNECTOR, AMPACT, SEE GND ASSEMBLY DRAWING FOR MATERIAL
5	1	LS913XX	DEADEND BOLTED STRAIN ALUMWELD
6	1	LS5012XX	CONNECTOR, AMPACT, VARIABLE CONDUCTOR SIZE TO VARIABLE CONDUCTOR SIZE
7	1	EN000390	LINK, CHAIN, XMSN: CONNECTING, CS, 1/2" PITCH; 2 1/4" LONG

FOR GROUNDING DETAIL AND MATERIALS SEE DWG. GND-XX.

See note 2

ALTERNATE PARTS
No. (LS913XX) deadend clamp
No. (LS5012XX) ampact connector

1) Item #2, #3 and #6 are conductor dependent.
 2) For grounding detail and materials, see applicable Gnd-xx drawing.
 3) For horizontal vang orientation, omit one of item 1.

OHG-DE-XX				
ENTERGY SERVICES, INC.				
Transmission LineDesign Standard OVERHEAD GROUNDWIRE DEADEND ASSY STRUCTURAL ASSEMBLY DETAIL				
STD NO.		SCALE: NONE		
		No. TMD222A6		
		PLOT 1=8 SH.1 OF 1		
OHG-DE-XX				

6	07-21-10	SHOW ITEM 4 ON ASSEMBLY	CBM	ECW	ECW
5	08-15-06	REVISED ITEM #4	RJL		
4	01-31-01	MODIFIED STOCK NUMBER LS5029XX	LS		
3	01-04-01	MODIFIED CALLOUTS	LS		
2	06-07-00	MODIFIED STOCK NUMBER LS5012XX	RMB		
1	11-16-99	ADDED AMPACT & CARTRIDGE DESCRIPTION	RMB		
0		ISSUED	ECSI		
NO.	DATE:	REVISION	BY:	CHK:	APPR:
	riafor	8/15/2006			

TEMP:AM-Work\ewillii2\W-LITAPETS\047_D-TDocs\S-Template\ESI\STANDARD\SDS\Transmission\AMISC\TMD222A6.DWG, 12/9/2010 4:32:05 PM, ewillii2

Appendix 2: High Voltage Overhead Transmission

Attachment 1: APPLICABLE STANDARD FRAMING AND ASSEMBLY DRAWINGS

BILL OF MATERIALS			
OHGW SUSPENSION, 0-30°			
ITEM	QTY.	STOCK NO.	DESCRIPTION
1	1	EN004375	BALL CLEVIS, 45 DEG Y, 30K ULT, 3/4" PIN DIA
2	1	LS9003XX	ROD, ARMOR, PREFORMED, ALUMINUM, VARIABLE CONDUCTOR SIZE
3	1	LS9008XX	CLAMP, SUSPENSION, ALUMINUM, VARIABLE WIRE SIZE, w/SOCKET EYE
4	-	LS5012XX	CONNECTOR, AMPACT

OHGW

(SEE NOTE 2)

PLAN

(SEE NOTE 2)

1) Item #2 and #3 are conductor dependent. These items are selected for each project and may be with or without Armor Rod.

2) For grounding detail and materials see applicable GND-XX drawing.

OHG-SUS-XX	
ENERGY STANDARD DWG.	
DESIGN APPROVAL	STANDARDS APPROVAL
SIGNED _____ / DATE _____	SIGNED _____ / DATE _____
<h3 style="margin: 0;">OVERHEAD GROUNDWIRE SUSPENSION ASSY</h3>	
APPROVED BY: _____	DATE: 2-15-03
CHECKED BY: _____	SCALE: NONE
DRAWN BY: ITRON	ESI NO. TMD223A9
No. OHGSUS	
PLOT 1=8 SH. 1 OF 1	

NO.	DATE:	REVISION	BY:	APPR:
9	8-15-06	REMOVED OPTGW OPTION, DELETED ITEM #4	RJL	
8	12-9-03	ADDED BACK GROUNDING DETAILS	ITRON	
7	5-30-03	ADDED OPTGW OPTION	ITRON	
6	2-17-03	ADDED POLE CAP AND GROUNDING NOTE 2	ITRON	
5	10-15-02	REMOVE GROUNDING DETAIL	ITRON	
4	1-18-02	MODIFIED ITEMS 1, 2 AND 3.	LSFT	
3	1-29-01	MODIFIED STOCK NUMBER LS9007XX	LSFT	
2	1-29-01	MODIFIED STOCK NUMBER LS5012XX	RMB	

TEMP:\AW-Work\willi2\IM-LITAPETSP047.D-TDdocs-S-Template\ESI\STANDARD\STransmission\AMISC\TMD223A9.dwg, 5/28/2010 5:09:35 PM, ewilliz

Appendix 2: High Voltage Overhead Transmission

Attachment 1: APPLICABLE STANDARD FRAMING AND ASSEMBLY DRAWINGS

BILL OF MATERIALS			
OHGW SUSPENSION, 30-50' WITH YOKE PLATE			
ITEM	QTY.	STOCK NO.	DESCRIPTION
1	2	EN000492	SHACKLE, ANCHOR, 40K ULT, 3/4" PIN DIA, 2-3/4" LONG
2	2	EN004375	BALL CLEVIS, 45 DEG Y, 30K ULT, 3/4 PIN DIA
3	1	EN015676	PLATE, YOKE, DUCTILE IRON, 18" WIDTH, 30K ULT, 3/4" GALV
4	1	LS9003XX	ROD, ARMOR, PREFORMED, ALUMINUM, VARIABLE CONDUCTOR SIZE
5	2	LS9007XX	CLAMP, SUSPENSION, ALUMINUM, VARIABLE SIZE WIRE, W/SOCKET EYE
6	-	LS5012XX	CONNECTOR, AMPACT, SEE GROUND ASSEMBLY DRAWING FOR MATERIAL

PLAN

DETAIL A
YOKE ASSEMBLY

1) ITEM #4 AND #5 ARE CONDUCTOR DEPENDENT. THESE ITEMS ARE SELECTED FOR EACH PROJECT AND MAY BE WITH OR WITHOUT ARMOR ROD.

2) FOR GROUNDING DETAIL AND MATERIALS SEE APPLICABLE GND-XX DRAWING.

OHG-SUY-XX	
ENTERGY STANDARD DWG.	
DESIGN APPROVAL	STANDARDS APPROVAL
SIGNED _____ / DATE _____	SIGNED _____ / DATE _____
OVERHEAD GROUNDWIRE HEAVY ANGLE ASSY	
APPROVED BY:	DATE: 1-29-01
CHECKED BY:	SCALE: NONE
DRAWN BY: ECSI	ESI NO. TMD224A6
	No. OHGSUY
	PLOT 1=16 SH. 1 OF 1

NO.	DATE:	REVISION	BY:	APPR:
6	8-15-06	REVISED ITEM #6	RJL	
5	12-8-03	ADDED BACK GROUNDING DETAILS	ITRON	
4	2-18-03	ADDED POLE CAP AND GROUNDING NOTE	ITRON	
3	1-29-01	MODIFIED STOCK NUMBER LS9007XX	LS	
2	6-7-00	MODIFIED STOCK NUMBER LS5012XX	RMB	
1	11-16-99	ADDED AMPACT & CARTRIDGE DESCRIPTION	RMB	

TEMP:\AW-Work\williiz\IM-LITAP\ETSP047.D-TDdocs\S-Template\ESI\STANDARD\STransmission\AMISC\TMD224A6.dwg, 5/28/2010 5:14:25 PM, ewilliz

Appendix 2: High Voltage Overhead Transmission

Attachment 1: APPLICABLE STANDARD FRAMING AND ASSEMBLY DRAWINGS

BILL OF MATERIALS			
TEE ASSY, BRACE POST FOR STEEL WITH BOLTS			
ITEM	QTY.	STOCK NO.	DESCRIPTION
1	1	EN000171	NUT, SQUARE, STL, GALV, ANSI-C135.1, 7/8" DIA, 9 THD
2	4	EN000426	NUT, LOCK, SQUARE, STL, GALV, ANSI-C135.1, 7/8" DIA, 9 THD
3	2	EN003796	WASHER, SQUARE CURVED, STL, GALV, ANSI-C135.1, 7/8" BOLT, 1/4" THK, 4"x4"
4	1	EN011909	PLATE, POLE EYE, GALV STL, DBL EYE, 70K ULT, 8" BOLT SPACING
5	2	LS909XX	BOLT, DOUBLE ARMING, 7/8"xVARIABLE LENGTH, GALV, w/4 SQ NUTS

- 1) All Double Arming Bolts shall be trimmed to avoid conflict with guys, grounding, conductors, etc. and painted with galvanized paint.
- 2) Grounding Lug location may be above or below assembly depending on pole tank ground location.

TEE-B-S	
ENERGY STANDARD DWG.	
DESIGN APPROVAL	STANDARDS APPROVAL
SIGNED _____ / DATE _____	SIGNED _____ / DATE _____
TEE ASSY (STEEL) BRACE	
APPROVED BY: EJJ	DATE: 12-19-00
CHECKED BY: JWS	SCALE: NONE
DRAWN BY: ECSI	ESI NO. TMD279A0
	No. TBS
	PLOT 1=8 SH. 1 OF 1

NO.	DATE:	REVISION	BY:	APPR:
-----	-------	----------	-----	-------

TEMP:\AM-Work\williiz\IM-LITAPETSP047.D-TDdocs.S-Template\ESI\STANDARD\STTransmission\AMISC\TMD279A0.DWG. 6/10/2010 5:04:20 PM. ewilliz

Appendix 2: High Voltage Overhead Transmission

Attachment 1: APPLICABLE STANDARD FRAMING AND ASSEMBLY DRAWINGS

BILL OF MATERIALS			
TEE ASSY, BRACE TO BRACE FOR STEEL WITH BOLTS			
ITEM	QTY.	STOCK NO.	DESCRIPTION
1	1	EN000171	NUT, SQUARE, STL, GALV, ANSI-C135.1, 7/8" DIA, 9 THD
2	4	EN000426	NUT, LOCK, SQUARE, STL, GALV, ANSI-C135.1, 7/8" DIA, 9 THD
3	2	EN011909	PLATE, POLE EYE, GALV STL, DBL EYE, 70K ULT, 8" BOLT SPACING
4	2	LS909XX	BOLT, DBL ARMING, 7/8"xVARIABLE LENGTH, GALV, w/4 SQ NUTS

- 1) All Double Arming Bolts shall be trimmed to avoid conflict with guys, grounding, conductors, etc. and painted with galvanized paint.
- 2) Grounding Lug location may be above or below assembly depending on pole tank ground location.

TEE-B-B-S	
ENERGY STANDARD DWG.	
DESIGN APPROVAL	STANDARDS APPROVAL
SIGNED _____ / DATE _____	SIGNED _____ / DATE _____
TEE ASSY (STEEL) BRACE - BRACE	
APPROVED BY: EJG	DATE: 12-19-00
CHECKED BY: JWS	SCALE: NONE
DRAWN BY: ECSI	ESI NO. TMD280A0
	No. TBBS
	PLOT 1=8 SH. 1 OF 1

NO.	DATE:	REVISION	BY:	APPR:
-----	-------	----------	-----	-------

TEMP:\AM-Work\williiz\IM-LITAPETSP047.D-TDdocs.S-Template\ESI\STANDARDSDS\Transmission\AMISC\TMD280A0.DWG. 6/10/2010 5:02:10 PM. ewilliz

Appendix 2: High Voltage Overhead Transmission

Attachment 1: APPLICABLE STANDARD FRAMING AND ASSEMBLY DRAWINGS

ITEM	TYP. QUANTITY FOR STR. w/			STOCK NO.	DESCRIPTION
	1 POLE	2POLE	3 POLE		
1	1 ***	2 ***	3 ***	EN013434	ROD, GROUND, 5/8"x8", COPPER CLAD
2	15 lb.**	30 lb.**	44 lb.**	EN000362	WIRE, COPPERWELD, #4 (.1158lbs/ft)
3	1 ***	2 ***	3 ***	EN008745	CONNECTOR, CADWELD, #4 TO TOP OF 5/8" GROUND ROD ("L")
4	1 *	2	2	LS5012XX	CONNECTOR, AMPACT, VARIABLE CONDUCTOR SIZE TO #4 COPPERWELD.
5	2	4	6	EN014861	TERMINAL, ELEC., GROUNDING LUG, 1/2" DIA., 13THD, BRONZE
6	-	-	-	EN012112	GROUNDING CLIP SUPPLIED BY POLE MFG.

* FOR DOUBLE SHIELD WIRE, DOUBLE QTY. OF ITEM 4. ITEM 4 IS NOT USED FOR GROUNDING OPGW TO POLE. FOR OPGW SEE DRAWING TMD396.
 ** QUANTITY FOR ITEM 2 IS TYPICAL FOR POLES UP TO 100' ABOVE GROUND HEIGHT.
 *** FOR HIGH-RESISTANCE SOILS, ADDITIONAL GROUND RODS WILL BE REQUIRED AND "T" CONNECTORS (EN009796) CAN BE USED TO FACILITATE ADDITIONAL RODS.

GENERAL

- REFERENCE "GROUNDING AND CATHODIC PROTECTION CONSTRUCTION SPECIFICATION", TRANSMISSION LINE STANDARD T00109 FOR GROUNDING REQUIREMENTS.
- REFERENCE DWGS. TMD222, TMD223 TMD224, AND TMD225 FOR OVERHEAD GROUND WIRE ASSEMBLIES; AND DWG. TMD390 FOR GUY TO POLE BONDING.
- REFERENCE DWGS. TMD396, TMD397, AND TMD398 FOR OPGW GROUNDING ASSEMBLIES.

GROUNDING - NON OPGW SHIELD WIRE TO POLE

- REMOVE POLE SUPPLIER PROVIDED GROUND CLIPS (2 ea. W/GREEN BOLTS) AND REPLACE WITH TERMINAL (GROUNDING) LUGS (ITEM 5) AS SHOWN.
- ATTACH POLE GROUND TO POLE BY THREADING THRU TERMINAL LUGS (ITEM 5). EXTEND GROUND WIRE THRU GROUNDING CLIP (ITEM 6) AND EXTEND 5' COILED.
- FOR SUSPENSION TYPE CONNECTION, CONNECT TO S.W. WITH AMPACT CONNECTOR (ITEM 4). APPROX. 5' BEYOND ARMOR ROD.
- FOR DEAD END CONNECTION, CONNECT TO JUMPER WITH AMPACT CONN. (ITEM 4). PROVIDE ENOUGH WIRE TO ALLOW FREE MOVEMENT OF S.W. OR JUMPER. REMOVE EXCESS.

GROUNDING FOR ALL POLES:

- PROVIDE GROUND WIRE BETWEEN THE TERMINALS (ITEM 5) AT TOP AND BELOW GROUND. BETWEEN THE BLOCKOUTS, THE WIRE MAY BE EXTERNAL OR INTERNAL. INTERNAL PROVIDES PROTECTION FROM THEFT AND SNAGGING BY EQUIPMENT.

OPTIONS FOR GROUNDING BELOW GROUNDLINE (WIRES BELOW GROUNDLINE MUST CONNECT TO BOTTOM TERMINAL):

- OPTION 1 - PROVIDE GROUND WIRE TO BUTT OF POLE AND FORM COIL OF WIRE (PANCAKE) ON CLIPS PROVIDED (GROUND RODS NOT USED).
- OPTION 2 - PROVIDE CONTINUOUS GROUND WIRE (NO SPLICE) FROM PANCAKE TO GROUND ROD AND OR COUNTER POISE.

GND-C-EMBED

ENTERGY SERVICES, INC.					
Transmission LineDesign Standard					
GROUNDING, CONCRETE POLE, DIRECT EMBED					
STRUCTURAL ASSEMBLY DETAIL					
STD NO.			SCALE: NONE		
No. TMD293A5					
			PLOT 1=32 SH.1 OF 1		

5	9-6-17	REV. NOTES 2 & 3, CLARIFY MULTI-POLE BOM	ECW	CDHH	JRA
4	9-30-16	UPDATED AND REFORMATED BOM'S AND NOTES	ECW	PL	JRA
3	08-11-10	CORRECTED ITEM #'S IN NOTES	CBM	ECW	ECW
2	12-31-09	ADD GROUND ROD DIM	HDR	RGR	ECW
1	07-24-06	REVISED ITEM #5	RMB		
0	02-11-03	ISSUED	ITRON		
NO.	DATE:	REVISION	BY:	CHK:	APPR:

ewill12 9/6/2017 GNDCEMB

Appendix 2: High Voltage Overhead Transmission

Attachment 1: APPLICABLE STANDARD FRAMING AND ASSEMBLY DRAWINGS

ITEM	TYP. QUANTITY FOR STR. w/			STOCK NO.	DESCRIPTION
	1 POLE	2 POLES	3 POLES		
1	1 *	2	2	LS5012XX	CONNECTOR, AMPACT, VARIABLE CONDUCTOR SIZE TO #4 COPPERWELD.
2	12 lb.**	24 lb.**	35 lb.**	EN000362	WIRE, COPPERWELD, #4 (.1158lbs/ft)
3	3	6	9	EN014861	TERMINAL, ELEC., GROUNDING LUG, 1/2" DIA., 13THD, BRONZE
4	-	-	-	EN012112	GROUNDING CLIP SUPPLIED BY POLE MFG.

* FOR DOUBLE SHIELD WIRE, DOUBLE QTY, OF ITEM 1. ITEM 1 IS NOT USED FOR GROUNDING OPGW TO POLE. FOR OPGW SEE DRAWING TMD396.
 ** QUANTITY FOR ITEM 2 IS TYPICAL FOR POLES UP TO 100' ABOVE GROUND HEIGHT.

GENERAL

- REFERENCE "GROUNDING APPLICATION GUIDELINE", TRANSMISSION LINE STANDARD T00109 FOR GROUNDING REQUIREMENTS.
- REFERENCE DWGS. TMD222, TMD223, TMD224, AND TMD225 FOR OVERHEAD GROUND WIRE ASSEMBLIES; AND DWG. TMD390 FOR GUY TO POLE BONDING.
- REFERENCE DWGS. TMD396, TMD397, AND TMD398 FOR OPGW GROUNDING ASSEMBLIES.

GROUNDING - NON-OPGW SHIELD WIRE TO POLE

- REMOVE POLE SUPPLIER PROVIDED GROUND CLIPS (2ea. W/GREEN BOLTS) AND REPLACE WITH TERMINAL (GROUNDING) LUGS (ITEM 3) AS SHOWN. ±
- ATTACH POLE GROUND TO POLE BY THREADING THRU TERMINAL LUGS. (ITEM 3). EXTEND GROUND WIRE THRU GROUNDING CLIP (ITEM 4) AND EXTEND 5' COILED.
- FOR SUSPENSION TYPE CONNECTION, CONNECT TO S.W. WITH AMPACT CONNECTOR (ITEM 1). APPROX. 5' BEYOND ARMOR ROD.
- FOR DEAD END CONNECTION, CONNECT TO JUMPER WITH AMPACT CONNECTOR (ITEM 1). PROVIDE ENOUGH WIRE TO ALLOW FREE MOVEMENT OF S.W. OR JUMPER. REMOVE EXCESS.

GROUNDING FOR ALL POLES

- PROVIDE GROUND WIRE BETWEEN THE TERMINALS (ITEM 3) AT TOP OF POLE AND BELOW TOP OF PILE BETWEEN THE BLOCKOUTS, THE WIRE MAY BE EXTERNAL OR INTERNAL. INTERNAL PROVIDES PROTECTION FROM THEFT.
- PROVIDE GROUND WIRE FROM BOTTOM TERMINAL TO GROUND NEMA PAD ON EXTERIOR OF PILE.
- PANCAKE IS NOT RECOMMENDED ON POLE BUTT BECAUSE OF INCOMPATIBLE METALS THAT MIGHT CONTRIBUTE TO CORROSION.

ANODES

- ANODES SHALL BE CONNECTED TO THE PILE AS DETAILED ON DWG. TMD299 AND INSTALLED ON DWG. TMD299 AND TMD302. ALL MATERIAL FOR ANODE INSTALLATION IS SHOWN ON DWG. TMD299.

GND-C-PILE				
ENTERGY SERVICES, INC.				
Transmission Line Design Standard				
Grounding, Concrete Pole, Steel Pile				
STRUCTURAL ASSEMBLY DETAIL				
NO.	DATE:	REVISION	BY:	CHK: APPR
3	9-6-17	REV. NOTES 2 & 3, CLARIFY MULTI-POLE BOM	ECW	CDHH JRA
2	9-30-16	UPDATED AND REFORMATED BOM'S AND NOTES	ECW	PL JRA
1	08-15-06	REPLACE ANGLE BRACKET WITH NEMA PAD, ITEM #	R.J.L.	
0	02-15-03	ISSUED	ITRON	
ewill12		9/6/2017		

GND-C-PILE	
No. TMD294A3 PLOT	SCALE: SH. OF

Appendix 2: High Voltage Overhead Transmission

Attachment 1: APPLICABLE STANDARD FRAMING AND ASSEMBLY DRAWINGS

ITEM	TYP. QUANTITY FOR STR. w/			STOCK NO.	DESCRIPTION
	1 POLE	2 POLES	3 POLES		
1	1**	2**	3**	EN013434	ROD, GROUND, 5/8"x8', COPPER CLAD
2	2 lb. ***	4 lb. ***	4 lb. ***	EN000362	WIRE, COPPERWELD, #4 (.1158lbs/ft)
3	1**	2**	3**	EN008745	CONNECTOR, CADWELD, #4 TO TOP OF 5/8" GROUND ROD ("L")
4	2	4	5	EN014861	TERMINAL, GROUNDING LUG, #8-2/0 TO 1/2-13, BRONZE ALLOY
5	1 *	2 *	2 *	LS5012XX	CONNECTOR, AMPACT, VARIABLE CONDUCTOR SIZE TO #4 COPPERWELD.

* FOR DOUBLE SHIELD WIRE, DOUBLE QTY. OF ITEM 5. ITEM 5 IS NOT USED FOR GROUNDING OPGW TO POLE.
 FOR OPGW SEE DRAWING TMD343.
 ** FOR HIGH-RESISTANCE SOILS, ADDITIONAL GROUND RODS WILL BE REQUIRED AND "T" CONNECTORS (EN009796) CAN BE USED TO FACILITATE ADDITIONAL RODS.
 *** SOFT DRAWN COPPER (32159134) MAY BE SUBSTITUTED FOR CONNECTIONS AT TOP OF POLE ONLY.

GENERAL

- REFERENCE "GROUNDING APPLICATION GUIDELINE", TRANSMISSION LINE STANDARD T00109 FOR GROUNDING REQUIREMENTS.
- REFERENCE DWGS. TMD222, TMD223, TMD224, AND TMD225 FOR OVERHEAD GROUND WIRE ASSEMBLIES; AND DWG. TMD389 FOR GUY TO POLE BONDING.
- REFERENCE DWGS. TMD389, TMD399, AND TMD402 FOR OPGW GROUNDING ASSEMBLIES.

GROUNDING - NON-OPGW SHIELD WIRE TO POLE

- ATTACH CONNECTING GROUND WIRE TO TERMINAL LUG (ITEM 4) AS DETAILED ON DET. "A", SHT. TMD301 AND TO SHIELD WIRE OR JUMPER WITH AMPACT CONNECTOR (ITEM 5).

GROUNDING - POLE TO GROUND ROD

- ATTACH CONNECTING GROUND WIRE TO TERMINAL LUG ON POLE AS DETAILED ON DET. "A" DWG. TMD300 AND TO GROUND ROD AS SHOWN ON THIS DWG.

ANODES

- ANODES SHALL BE CONNECTED TO THE POLE AS DETAILED ON DET. "A" DWG. TMD300 AND INSTALLED ON DWG. TMD302. ALL MATERIAL FOR ANODE INSTALLATION IS SHOWN ON DWG. TMD300.

GND-S-EMBED

ENTERGY SERVICES, INC.

Transmission Line Design Standard

GROUNDING, STEEL POLE, DIRECT EMBED

STRUCTURAL ASSEMBLY DETAIL

4	9-6-17	REV. NOTES 2/3, CLARIFY MULTI-POLE BOM, ALT. ITEM 1	ECW	CDHH	JRA
3	9-30-16	UPDATED AND REFORMATED BOM'S AND NOTES	ECW	PL	JRA
2	12-21-09	ADDED GROUND ROD DIMENSION	HDR	RLR	ECW
1	07-24-06	REVISED ITEM #5	RMB		
0	02-11-03	ISSUED	ITRON		
NO.	DATE:	REVISION	BY:	CHK:	APPR:

ewill12 9/6/2017

Appendix 2: High Voltage Overhead Transmission

Attachment 1: APPLICABLE STANDARD FRAMING AND ASSEMBLY DRAWINGS

TYP. QUANTITY FOR STR. w/				BILL OF MATERIALS – GROUNDING	
ITEM	1 POLE	2 POLES	3 POLES	STOCK NO.	DESCRIPTION
1	1 *	2	2	LS5012XX	CONNECTOR, AMPACT, VARIABLE CONDUCTOR SIZE TO #4 COPPERWELD.
2	2 lb. **	4 lb. **	6 lb. **	EN000362	WIRE, COPPERWELD, #4 (.115lbs/ft)
3	0	0	0	–	–
4	3	6	8	EN014861	TERMINAL, GROUNDING LUG, #8–2/0 TO 1/2–13, BRONZE ALLOY

* FOR DOUBLE SHIELD WIRE, DOUBLE QTY. OF ITEM 1. ITEM 1 IS NOT USED FOR GROUNDING OPGW TO POLE. FOR OPGW SEE DRAWING TMD343.
 ** SOFT DRAWN COPPER (32159134) MAY BE SUBSTITUTED FOR CONNECTIONS AT TOP OF POLE ONLY.

GENERAL

- REFERENCE "GROUNDING APPLICATION GUIDELINE", TRANSMISSION LINE STANDARD T00109 FOR GROUNDING REQUIREMENTS.
- REFERENCE DWGS. TMD222, TMD223 TMD224, AND TMD225 FOR OVERHEAD GROUND WIRE ASSEMBLIES; AND DWG. TMD389 FOR GUY TO POLE BONDING.
- REFERENCE DWGS. TMD389, TMD399, AND TMD402 FOR OPGW GROUNDING ASSEMBLIES.

GROUNDING – NON–OPGW SHIELD WIRE TO POLE

- ATTACH CONNECTING GROUND WIRE TO TERMINAL LUG (ITEM 4) AS DETAILED ON DET. "A", SHT. TMD301 AND TO SHIELD WIRE OR JUMPER WITH AMPACT CONNECTOR (ITEM 5).

GROUNDING – POLE TO PILE

- ATTACH GROUND WIRE TO POLE BY THREADING THROUGH TERMINAL LUG AS SHOWN ON DET. "A", DWG. TMD301. ATTACH GROUND WIRE TO PILE WITH GROUNDING CONNECTOR AS SHOWN ON DETAIL "B", DWG. TMD301.

ANODES

- ANODES SHALL BE CONNECTED TO THE PILE AS DETAILED ON DET. "A", DWG. TMD299 AND INSTALLED ON DWG. TMD302 AND TMD299. ALL MATERIAL FOR ANODE INSTALLATION IS SHOWN ON DWG. TMD299.

GND–S–PILE					
ENTERGY SERVICES, INC.					
Transmission Line Design Standard					
Grounding, Steel Pole, Steel Pile					
STRUCTURAL ASSEMBLY DETAIL					
4	9–6–17	REV. NOTES 2/3, CLARIFY MULTI–POLE BOM, ALT. ITEM 1	ECW	CDHH	JRA
3	9–30–16	UPDATED AND REFORMATED BOM'S AND NOTES	ECW	PL	JRA
2	1–5–15	DELETE ITEM 3, REV. QUAN. ITEM 4	ECW	FWM	WLS
1	7–24–06	REVISED ITEM #1	RMB		
0	02–12–03	ISSUED	ITRON		
NO.	DATE:	REVISION	BY:	CHK:	APPR:
ewill12		9/6/2017			

Transmission Line Design Standard

No. TMD296A4

SCALE:

PLT OF

GND–S–PILE

Appendix 2: High Voltage Overhead Transmission

Attachment 1: APPLICABLE STANDARD FRAMING AND ASSEMBLY DRAWINGS

ITEM	TYP. QUANTITY FOR STR. w/			STOCK NO.	DESCRIPTION
	1 POLE	2 POLES	3 POLES		
1	1**	2**	3**	EN013434	ROD, GROUND, 5/8"x8", COPPER CLAD
2	2 lb. ***	4 lb. ***	6 lb. ***	EN000362	WIRE, COPPERWELD, #4 (.1158lbs/ft)
3	1**	2**	3**	EN008745	CONNECTOR, CADWELD, #4 TO TOP OF 5/8" GROUND ROD ("L")
4	2	4	5	EN014861	TERMINAL, GROUNDING LUG, #8-2/0 TO 1/2-13, BRONZE ALLOY
5	1 *	2 *	2 *	LS5012XX	CONNECTOR, AMPACT, VARIABLE CONDUCTOR SIZE TO #4 COPPERWELD.

* FOR DOUBLE SHIELD WIRE, DOUBLE QTY, OF ITEM 5. ITEM 5 IS NOT USED FOR GROUNDING OPGW TO POLE.
 FOR OPGW SEE DRAWING TMD343.
 ** FOR HIGH-RESISTANCE SOILS, ADDITIONAL GROUND RODS WILL BE REQUIRED AND "T" CONNECTORS (EN009796) CAN BE USED TO FACILITATE ADDITIONAL RODS.
 *** SOFT DRAWN COPPER (32159134) MAY BE SUBSTITUTED FOR CONNECTIONS AT TOP OF POLE ONLY.

GENERAL

- REFERENCE "GROUNDING APPLICATION GUIDELINE", TRANSMISSION LINE STANDARD T00109 FOR GROUNDING REQUIREMENTS.
- REFERENCE DWGS. TMD222, TMD223, TMD224, AND TMD225 FOR OVERHEAD GROUND WIRE ASSEMBLIES; AND DWG. TMD389 FOR GUY TO POLE BONDING.
- REFERENCE DWGS. TMD389, TMD399, AND TMD402 FOR OPGW GROUNDING ASSEMBLIES.

GROUNDING - NON-OPGW SHIELD WIRE TO POLE

- ATTACH CONNECTING GROUND WIRE TO TERMINAL LUG AS DETAILED ON DET. "A", SHT. TMD301 AND TO SHIELD WIRE OR JUMPER WITH AMPACT CONNECTOR (ITEM 5).

GROUNDING - POLE TO GROUND ROD

- ATTACH CONNECTING GROUND WIRE TO TERMINAL LUG (ITEM 4) ON POLE AS DETAILED ON DET. A DWG. TMD301 AND TO GROUND ROD AS SHOWN ON THIS DWG.

GND-S-PIER					
ENTERGY SERVICES, INC.					
Transmission Line Design Standard GROUNDING, STEEL POLE, CONCRETE DRILLED PIER STRUCTURAL ASSEMBLY DETAIL					
5	9-6-17	REV. NOTES 2/3, CLARIFY MULTI-POLE BOM, ALT. ITEM 1	ECW	CDHH	JRA
4	9-30-16	UPDATED AND REFORMATED BOM'S AND NOTES	ECW	PL	JRA
3	12-21-09	ADDED GROUND ROD DIMENSION	HDR	RLR	ECW
2	07-24-06	REVISED ITEM #5	RMB		
1	01-25-05	REMOVED ANODES	RMB		
NO.	DATE:	REVISION	BY:	CHK:	APPR:

ewill12 9/6/2017

Scale: NONE
 No. TMD297A5
 PLOT 1=32 SH. 1 OF 1

GND-S-PIER

Appendix 2: High Voltage Overhead Transmission

Attachment 1: APPLICABLE STANDARD FRAMING AND ASSEMBLY DRAWINGS

BILL OF MATERIALS			
ITEM	QTY.	STOCK NO.	DESCRIPTION
1	1*	EN013170	HANDLE; CLAMP, METAL; CADWELD, FITS C/E/R 3" MOLDS (1 PER 50 CONN.)
2	3	SEE DWG TMD302	ANODE, W/#6 AWG., SIZE AND MATERIAL VARY WITH INSTALLATION
3	1*	32122722	MOLD, EXOTHERMIC, 3/0 STR. CU CABLE TO 1/4"X-1 1/2"LUG, (1 PER 50 CONN.)
4	1.5	EN019108	CARTRIDGE, THERMOWELD POWDER; #90 CHARGE, CADWELD METAL
5	1	EN019109	SLEEVE: CADWELD; ADAPTER SLEEVES ARE USED TO ADAPT 1/0, 1 STR
6	1	32074891	NEMA 1-HOLE COPPER BUS BAR FOR PIPE PILE FOUNDATIONS
7	1	EN019252	COMPOUND: ELECTRICAL JOINT, INHIBITOR, GREASE LIKE, 8 OZ TUBE
8	1	0000018450	ASSEMBLY, BOLT: MACH, SS, 1/2" DIA. x 1" LG. W/NUT & WASHERS. SEE NOTE 5.

* - ORDER ONE EA. PER 50 CONNECTIONS

PLAN VIEW

3'-4' SLACK LOOP IN EACH ANODE LEAD CABLE

(3) ANODES INSTALLED 10" DIA. HOLE 10' DEEP 120 DEGREES APART.

#6 AWG 7 STRAND ANODE LEAD TRENCHED IN 18" DEEP

SEE DETAIL "A" FOR ANODE TERMINATION

ELEVATION VIEW

CONC. OR STEEL POLE

SEE DETAIL "A" (DWG. TMD302)

TO ANODES

STEEL PILE

1 1/2"X3 1/2" 2-HOLE NEMA GROUND PAD EXIST ON PILE.

6

8

8

4 3

1

5

DETAIL "A"

2 (3 TYP.)

NOT INSTALLED

NOTES

- 1) FOR INSTALLATION OF ANODES REFER STANDARD T00109 AND DWG. TMD302.
- 2) COAT ALL MECHANICAL CONNECTIONS (THREADS AND BUS BAR TO NUTS) WITH ELECTRICAL JOINT INHIBITOR COMPOUND.
- 3) ANODE MATERIAL PROVIDED TO PROTECT STEEL PILE. SEE DWG. TMD296 FOR BONDING OF STEEL POLE TO STEEL PILE.
- 4) USE GALVANIZING TOUCH-UP EN019331 IF REQUIRED.
- 5) ITEM 8 HAS 1 NUT & 1 WASHER THAT WILL NOT BE USED.

ANODE-S-PILE

ENTERGY SERVICES, INC.

Transmission LineDesign Standard
ANODE INSTALLATION DETAILS FOR STEEL PILES
STRUCTURAL ASSEMBLY DETAIL

STD NO. T00109 SCALE: NONE

No. TMD299A3

PLOT 1=32 SH. 1 OF 1

3	8-21-14	REV. STK NO. ITEM 6, CHANGE MOLD ITEM 3	ECW	WLS
2	03-17-14	REVISED ITEMS 2 & 6, NOTES 1 & 3	ECW	JRA WLS
1	08-10-06	GENERAL DRAWING REVISION	RJL	
0	2-11-03	CREATED	ITRON	
NO.	DATE	REVISION	BY:	CHK: APPR:

EWILLI2 8-21-14 Entergy ANODE-S-PILE

Appendix 2: High Voltage Overhead Transmission

Attachment 1: APPLICABLE STANDARD FRAMING AND ASSEMBLY DRAWINGS

BILL OF MATERIALS			
ITEM	QTY.	STOCK NO.	DESCRIPTION
1	1*	EN013170	HANDLE; CLAMP, METAL; CADWELD, FITS C/E/R 3" MOLDS (1 PER 50 CONN.)
2	3	SEE DWG. TMD302	ANODE, W/#6 AWG., SIZE AND MATERIAL VARY WITH INSTALLATION
3	1*	32122722	MOLD, EXOTHERMIC, 3/0 STR. CU CABLE TO 1/4"X-1 1/2" (1 PER 50 CONN.)
4	1.5	EN019108	CARTRIDGE, THERMOWELD POWDER; #90 CHARGE, CADWELD METAL
5	1	EN019109	SLEEVE: CADWELD; ADAPTER SLEEVES ARE USED TO ADAPT 1/0, 1 STR
6	1	32074891	NEMA 1-HOLE COPPER BUS BAR FOR PIPE PILE FOUNDATIONS
7	1	EN019252	COMPOUND: ELECTRICAL JOINT, INHIBITOR, GREASE LIKE, 8 OZ TUBE
8	1	000018450	ASSEMBLY, BOLT: MACH, SS, 1/2" DIA. x 1" LG. W/NUT AND WASHERS. (SEE NOTE 5)

* - ORDER ONE EA. PER 50 CONNECTIONS

PLAN VIEW

(3) ANODES INSTALLED 10" DIA. HOLE 10' DEEP, 120 DEGREES APART

#6 AWG 7 STRAND ANODE LEAD TRENCHED IN 18" DEEP

SEE DETAIL "A" FOR ANODE AND GROUNDING TERMINATION

3'-4' SLACK LOOP IN EACH ANODE LEAD CABLE

ELEVATION VIEW

STEEL POLE

SEE DETAIL "A"

TO GROUND ROD

TO ANODES

DETAIL "A"

1 1/2"X3 1/2" 2-HOLE NEMA GROUND PAD EXIST ON POLE.

EN014861 (TERMINAL, GROUNDING LUG)

6

8

4 3

1

5

NOT INSTALLED

2 (3 TYP.)

- 1) FOR INSTALLATION OF ANODES REFER TO STANDARD T00109 AND DWG. TMD302.
- 2) COAT ALL MECHANICAL CONNECTIONS (THREADS AND BUS BAR TO NUTS) WITH ELECTRICAL JOINT INHIBITOR COMPOUND.
- 3) ANODES NOT REQUIRED FOR POLES SUPPORTED ON CONC. DRILLED PIERS, OR POLES BACKFILLED WITH CONCRETE. SEE DWG. TMD296 FOR BONDING OF STEEL POLE TO STEEL PILE.
- 4) USE GALVANIZING TOUCH-UP EN019331 IF REQUIRED.
- 5) ITEM 8 HAS 1 NUT & 1 WASHER THAT WILL NOT BE USED.

ANODE-S-EMBED/PIER

ENTERGY SERVICES, INC.

Transmission LineDesign Standard

ANODE INSTALLATION DETAILS FOR STEEL POLES

STRUCTURAL ASSEMBLY DETAIL

STD NO. T00109 SCALE: NONE

No. TMD300A4

Plot 1=32 SH. 1 OF 1

ANODE-S-EMBED/PIER

4	8-21-14	REV. STK. NO. ITEM 6, CHANGE MOLD ITEM 3	ECW	WLS
3	03-17-14	REVISED ITEMS 2 & 6, NOTES 1 & 3	ECW	JRA WLS
2	8-10-06	REVISED ITEM 8, DEL ITEM 9, ADDED NOTE 4 & 5	MDB	
1	2-15-03	UPDATE MATERIALS LIST	ITRON	
0	2-11-03	CREATED	ITRON	
ND.	DATE:	REVISION	BY:	CHK: APPR:

EWILLI2 8-21-14

Appendix 2: High Voltage Overhead Transmission

Attachment 1: APPLICABLE STANDARD FRAMING AND ASSEMBLY DRAWINGS

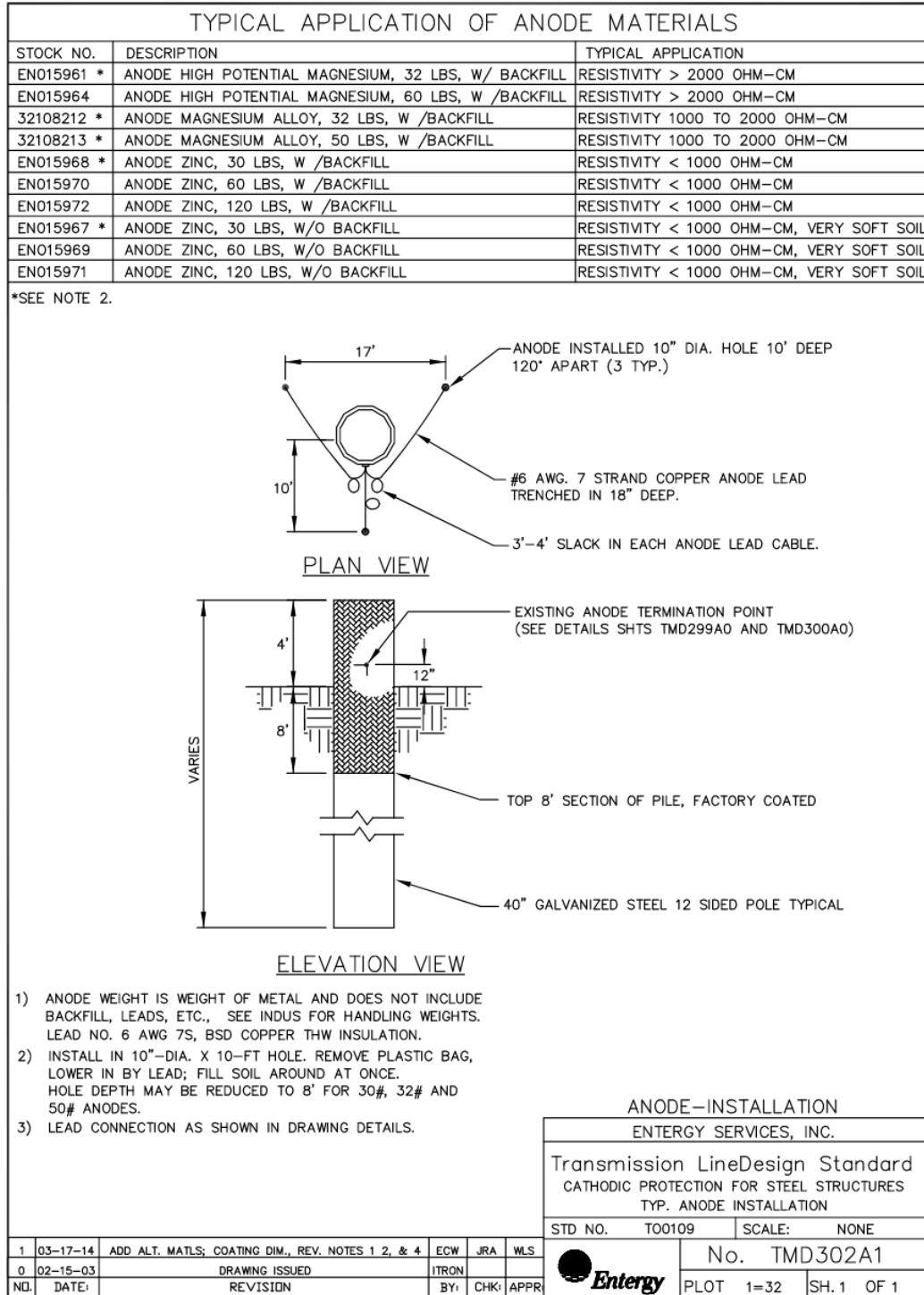

Appendix 2: High Voltage Overhead Transmission

Attachment 1: APPLICABLE STANDARD FRAMING AND ASSEMBLY DRAWINGS

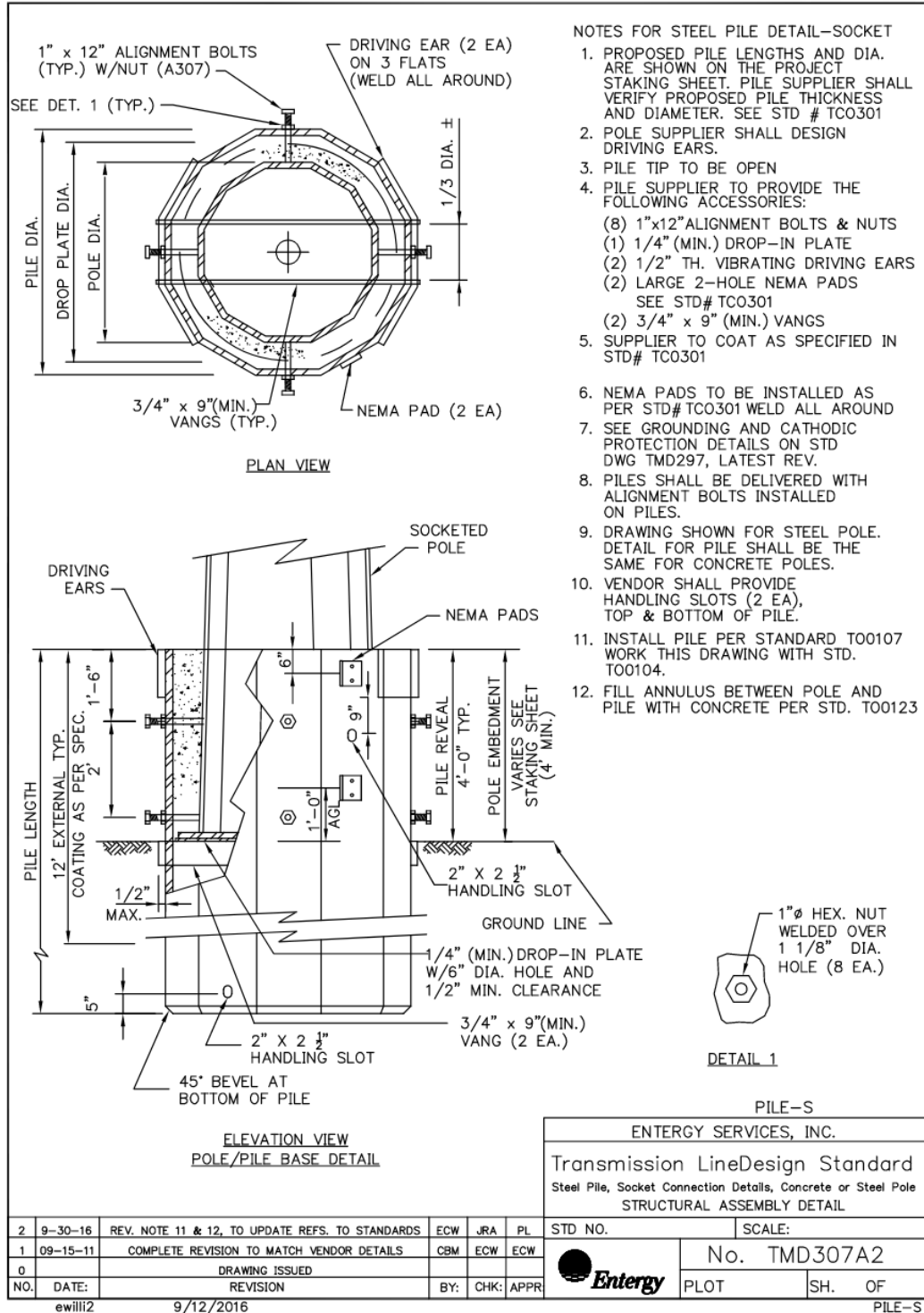

C:\Temp\AM-WorK\ewill12\AM-JDCAPE\TSP047.D-TDocs.S-Template\ES\STANDARDS\Transmission\AMISCTMD307A2.dwg, 10/5/2016 12:59:33 PM, ewill12

Appendix 2: High Voltage Overhead Transmission

Attachment 1: APPLICABLE STANDARD FRAMING AND ASSEMBLY DRAWINGS

BILL OF MATERIALS			
SPLICE BOX, POLE			
ITEM	QTY.	STOCK NO.	DESCRIPTION
1	1	0032018592	SPLICE BOX: FIBER OPTIC, HOLES FOR 1/2" LAG SCREW OR BOLT
2	1	0032026880	ADAPTER, ASSEMBLY, BANDING, FIBER OPTIC, FOR 3/4 BAND, CONSISTING OF TWO ADAPTERS AND TWO 1/2" HEX BOLT ASSEMBLIES
3	12	LS9014XX	CLAMP, DOWNLEAD: FIBER OPTIC, WITH BANDING ADAPTER
4	1 ROLL	0000017124	BAND, STRAPPING, 3/4" WD X 100FT LG ROLL, STAINLESS STEEL, 201
5	12	0000017123	CLAMP, BAND: ADJUSTABLE, 3/8" X 6" BOLT, FOR 3/4" BAND

ITEM #3 AVAILABLE

57MM	0032038843	0.400-0.500" DIA
64MM	0032038845	0.501-0.600" DIA
52MM	0032038846	0.601-0.700" DIA
92MM	0032038846	0.601-0.700" DIA

NOTES

- ITEM #3 IS OPGW DEPENDENT. THIS ITEM IS SELECTED FOR EACH PROJECT.
- PROVIDE ENOUGH OPGW TO REACH GROUNDLINE PLUS 35 FEET.
- IN AREAS ACCESSIBLE TO THE PUBLIC MAINTAIN 15' MINIMUM OPGW AND SPLICE BOX CLEARANCE TO GROUND OR TOP OF ACCESSIBLE SURFACES*. WORK WITH DRAWING SMC005, CURRENT REV.
- IN SUBSTATIONS OR OTHER AREAS INACCESSIBLE TO THE PUBLIC, SPLICE BOX MAY BE LOCATED 5' ABOVE THE GROUND SURFACE PROVIDED THE THE ADSS IS SECURED. MEANS OF SECURING ADSS PROVIDED BY OTHERS.
- WHEN SPLICING TO UNDERGROUND ADSS CONTRACTOR TO PROVIDE LENGTH AS REQUIRED OF GALV. STL. 2" SCHED. 40 CONDUIT OR APPROVED EQUAL. CONDUIT TO BE FORMED AROUND POLE FOUNDATION WHERE PRESENT, AND EXTEND 1.5' MINIMUM BELOW GRADE AS SHOWN. CONDUIT TO BE SECURED WITH 3/4" STRAP MATERIAL.

ENTERGY SERVICES, INC.			Transmission LineDesign Standard		
SPLICE BOX, POLE			STRUCTURAL ASSEMBLY DETAIL		
5	9-6-17	ADD GUARD PIPE, REV NOTES 1 - 3, ADD NOTE 4 & 5	ECW	CDHH	JRA
4	2-18-10	CHANGED UNITS FOR ITEM 4	TWF	HSK	HSK
3	12-08-09	REPLACE ITEM NOS. IN BOM	HDR	ECW	ECW
2	8-3-07	REPL. ADAPT. W/ ASSY, REV. DIA. RANGES	TWF	HSK	HSK
1	05-15-07	REVISED NAME & DESCRIPTION	TWF	HSK	HSK
NO.	DATE:	REVISION	BY:	CHK:	APPR:
ewillii2		9/6/2017			

ENTERGY		No. TMD337A5	
PLOT 1=1		SH.1 OF 1	
SCALE: NONE		SB-P-XX	

Appendix 2: High Voltage Overhead Transmission

Attachment 1: APPLICABLE STANDARD FRAMING AND ASSEMBLY DRAWINGS

BILL OF MATERIALS			
OVERHEAD GROUND WIRE, DEADEND, OPGW, POLE			
ITEM	QTY.	STOCK NO.	DESCRIPTION
1	1	LS9011XX	DEADEND: BOLTED STRAIN, OPGW, 3/4" PIN DIA.
2	1	0000012586	LINK, CHAIN: 5/8" X 3-1/4", 40K
3	1	0000024787	CLEVIS CLEVIS: Y-Y, 30K, 3/4" PD, 15" LONG

NOTE: ILLUSTRATED AS TANGENT OR SMALL ANGLE STRUCTURE. LARGER ANGLES WILL HAVE THE PULLOFFS AT DIFFERENT ELEVATIONS BY SEVERAL INCHES.

NOTE: FOR NON-SPLICE BOX LOCATIONS, MAINTAIN CONTINUOUS LOOP AND DO NOT CUT OPGW.

NOTE: FOR SPLICE BOX LOCATIONS, PROVIDE ENOUGH WIRE TO REACH THE GROUNDLINE, PLUS 15 FEET.

ITEM #1 AVAILABLE

57MM	0000018531	0.465" DIA
64MM	0032018594	0.528" DIA
52MM	0032018595	0.646" DIA
92MM	0032018596	0.671" DIA

1) ITEM #1 IS OPGW DEPENDENT.
THIS ITEM IS SELECTED FOR EACH PROJECT.

OHG-DE-OP-P-XX

ENTERGY SERVICES, INC.

Transmission Line Design Standard
OVERHEAD GRNDWIRE, DE, OPGW, POLE
STRUCTURAL ASSEMBLY DETAIL

2	5-15-07	REVISED NOTES, NAME & DESCRIPTION	TWF	HSK	HSK	STD NO.	SCALE: NONE
1	8-23-06	UPDATED BILL OF MATERIAL	RJL	HSK	HSK		No. TMD339A2 PLOT 1=1 SH. 1 OF 1
0	X	CREATED		HSK	HSK		
NO.	DATE:	REVISION	BY:	CHK:	APPR:		

tfinc90
6/25/2007
OHG-DE-OP-P-XX

TEMP:\AW-Work\ewillii\2M-LITAPETSP047.D-TDdocs\S-Template\ESI\STANDARD\STTransmission\MISC\TMD339A2.dwg, 5/28/2010 5:03:37 PM, ewillii2

Appendix 2: High Voltage Overhead Transmission

Attachment 1: APPLICABLE STANDARD FRAMING AND ASSEMBLY DRAWINGS

BILL OF MATERIALS				
OVERHEAD GROUND WIRE, SUSP. 30-50° w/YOKE, OPGW				
ITEM	QTY.	STOCK NO.	DESCRIPTION	
1	1	LS9010XX	CLAMP, SUSP: DOUBLE (2 CLAMPS), ALUM AL, 15K, W/48" ARM RODS, 30-60° MAX. ANGLE	
2	2	0032020410	CLEVIS EYE: STRAIGHT, 30K, 2-7/8" LG, 1-5/8" EYE WD, 3/4" EYE RAD, 5/8" PIN DIA	
3	1	0032020414	PLATE, YOKE: DELTA, DUCTILE IRON, 18" LONG, 30K	
4	1	0000004375	BALL CLEVIS: 45 DEG Y, 30K, 3/4" PD, CLASS 52-3/5	
5	1	0000000486	SOCKET CLEVIS: STRAIGHT, 30K, 5/8" PD, CLASS 52-3/5	

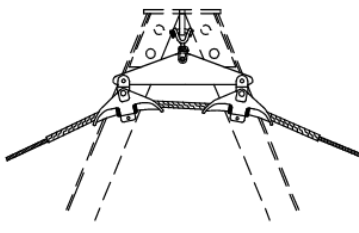

AS ON LATTICE TOWER

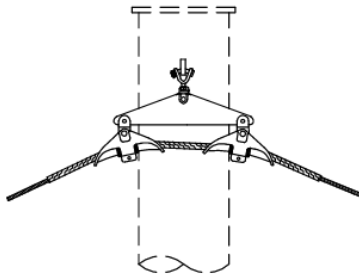

AS ON POLE

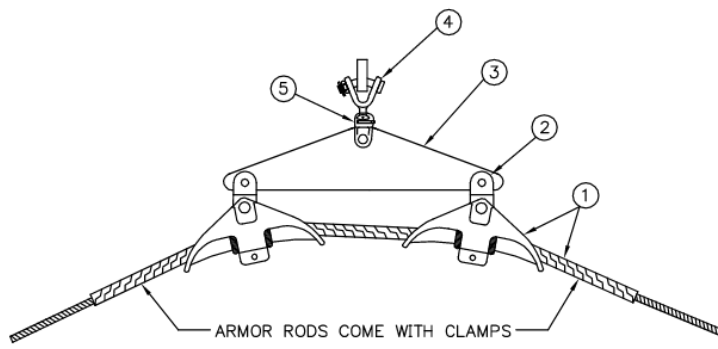

— ARMOR RODS COME WITH CLAMPS —

ITEM #1 AVAILABLE

57MM	0032018593	0.450-0.475" DIA
64MM	0000017195	0.528-0.555" DIA
52MM	0000017196	0.615-0.646" DIA
92MM	0000017198	0.647-0.679" DIA

1) ITEM #1 OPGW DEPENDENT.
THIS ITEM IS SELECTED FOR EACH PROJECT.

OHG-SUY-OP-XX				
ENTERGY SERVICES, INC.				
Transmission Line Design Standard OVERHEAD GRNDWIRE, SUSP 30-50 W/YOKE, OPGW STRUCTURAL ASSEMBLY DETAIL				
STD NO.		SCALE: NONE		
		No. TMD341A2		
		PLOT 1=1 SH. 1 OF 1		

2	5-15-07	REVISED NAME & DESCRIPTION. COMBINED DWGS TMD340 & TMD341	TWF	HSK	HSK
1	8-01-06	EXPANDED DESCRIPTIONS OF ITEMS 1 & 2	CDR	HSK	HSK
0	5-24-04	CREATED	.	HSK	HSK
NO.	DATE:	REVISION	BY:	CHK:	APPR

tfinc90
6/25/2007

OHG-SUY-OP-XX

TEMP:\AW-Work\williiz\IM-LITAPETSP047.D-TDdocs-S-Template\ESI\STANDARD\STTransmission\MISC\TMD341A2.dwg, 5/28/2010 5:16:29 PM, ewilliz

Appendix 2: High Voltage Overhead Transmission

Attachment 1: APPLICABLE STANDARD FRAMING AND ASSEMBLY DRAWINGS

BILL OF MATERIALS					
GROUND, SUSP. 0-30', OPGW, STEEL POLE					
ITEM	QTY.	STOCK NO.	DESCRIPTION		
1	1	0032033755	JUMPER, STATIC LINE: MULTI-STRANDED TINNED COPPER, 133/.0177, 48" LG, W/TERMINALS		
2	1	0000018450	ASSEMBLY, BOLT: MACH, SS, HEX HEAD, 1/2" DIA. X 1" LG., WITH NUT, 2 WASHERS AND 1 BELLEVILLE WASHER		

BOLT COMES WITH CLAMP
48" JUMPER LENGTH
SEE NOTES 3 & 4 FOR ALTS.

NOTES:

1. ITEM 1 CAN BE MADE UP WITH 48" OF THE WIRE (0032018798) AND TWO TERMINALS (0032031548) AND COMPRESSING THE TERMINALS WITH AN INDENT DIE.
2. ITEM 2 HAS 1 NUT AND 1 WASHER THAT WILL NOT BE NEEDED.
3. USE 72" JUMPER (0032052394) FOR APPLICATION ON POLES WITH 3 FOOT SW DAVIT ARMS.
4. SEE DRAWING TMQ207 FOR OTHER AVAILABLE JUMPER LENGTHS.

GND-SUS-OP-S					
ENTERGY SERVICES, INC.					
Transmission LineDesign Standard GROUND, SUSP, 0-30, OPGW, STEEL POLE STRUCTURAL ASSEMBLY DETAIL					
3	3-26-14	ADD NOTES 3 AND 4 WITH ALT. JUMPER LENGTHS.	ECW	JRA	WLS
2	3-15-07	REV. NOTES, NAME & DESCRIPTION. SIDE VIEW ADDED.	TWF	HSK	HSK
1	8-17-06	DELETED 1 BOLT ON CLAMP, MADE JUMPER AND TERMINALS AN ASSEMBLY	RJL	HSK	HSK
0	5-24-04	CREATED	.	HSK	HSK
ND.	DATE:	REVISION	BY:	CHK:	APPR:

		No. TMD343A3
PLOT	1=1	SH. 1 OF 1

GND-SUS-OP-S

Appendix 2: High Voltage Overhead Transmission

Attachment 1: APPLICABLE STANDARD FRAMING AND ASSEMBLY DRAWINGS

BILL OF MATERIALS					
COIL BRACKET, OPGW, STEEL POLE					
ITEM	QTY.	STOCK NO.	DESCRIPTION		
1	1	0032031230	BRACKET, COIL: 60 INCH, GALV. STEEL, PER ENTERGY DWG TMM060A		
2	2	-	BOLT, MACHINE, 1/2"-13 X 1", ALL THREAD, GALV. STEEL, NO NUT, NO WASHER (ANY SUPPLIER)		
3	0	0000000139	BOLT ASSEMBLY, MACHINE: HEX HEAD, GALV. STEEL, 5/8"-11 X 1-1/2", WITH HEX NUT		
4	0	0000005532	WASHER, ROUND, FLAT, 1 1/16" ID, 1-1/2" OD, 1/8" THICK, ASTM A153, GALV. STEEL		
5	0	0032031232	PLATE, BENT, GALV. STEEL, PER ENTERGY DWG. TMM061A		

NOTE #1: ASSEMBLY WILL TYPICALLY BE Banded TO POLE USING 3/4" SS BAND MATERIAL AND ADAPTERS SUPPLIED WITH THE SPLICE BOX. ALTERNATELY, THE COIL BRACKET ASSEMBLY MAY BE SECURED WITH TWO 1/2" BOLTS (ITEM 2) USING ANY TWO OF THE FOUR THREADED RECEIVER PROVIDED.

NOTE #2: TWO EACH OF ITEMS 3 AND 5, AND FOUR OF ITEM 4 MAY ALSO BE USED TO SECURE THE COIL BRACKET ASSEMBLY TO POLES ALREADY IN SERVICE THAT WERE MANUFACTURED WITH STEP CLIPS. THE STEP CLIP DETAIL IS COMMON ON OLDER POLES MANUFACTURED BY THOMAS & BETTS.

NOTE #3: COIL BRACKET ASSEMBLY CAN BE INSTALLED WITH EITHER END UP. BEFORE TIGHTENING BOLTS, BE SURE THAT WEIGHT OF COMPONENTS PULLS THEM FIRMLY INTO SLOTTED HOLES IN THE CHANNEL.

NOTE #4: THE LOWEST PART OF THE INSTALLATION MUST BE A MINIMUM OF 15 FEET ABOVE GROUNDLINE AND THE CABLE MUST COME INTO THE BOTTOM OF THE SPLICE BOX WITH NO STRAIN ON THE CONNECTORS. ADDITIONAL BANDING MAY BE NECESSARY TO GATHER AND STABILIZE THE EXCESS CABLE LENGTH TO THE BRACKET AND POLE. HOLES ARE PROVIDED IN THE END OF EACH ARM TO ACCOMMODATE CABLE TIES OR WIRE TIES.

15' MINIMUM ABOVE GL. IF ALTERNATE SPLICE BOX LOCATION IS USED, NO PART OF INSTALLATION CAN BE LOWER THAN 15' ABOVE THE GROUND LINE.

CB-OP-S

ENTERGY SERVICES, INC.	
Transmission LineDesign Standard	
COIL BRACKET, OPGW, STEEL POLE	
STRUCTURAL ASSEMBLY DETAIL	
STD NO.	SCALE: NONE
No. TMD386A3	
PLOT	1=1 SH. 1 OF 1

3	9-24-15	ADD REF. LINE FOR 15' MIN. DIMENSION	ECW	ECW
2	8-21-14	QTY. ITEMS 3-5, REV. NOTES 1 & 2	ECW	WLS
1	5-15-07	REVISED NAME & DESCRIPTION	TWF	HSK
0	3-30-06	CREATED	RMB	HSK
NO.	DATE	REVISION	BY:	CHK/ APPR

EWILLJ 08-24-15 CB-OP-S

Appendix 2: High Voltage Overhead Transmission

Attachment 1: APPLICABLE STANDARD FRAMING AND ASSEMBLY DRAWINGS

BILL OF MATERIALS			
COIL BRACKET, OPGW, CONCRETE POLE			
ITEM	QTY.	STOCK NO.	DESCRIPTION
1	1	0032031230	BRACKET, COIL, 60 INCH, GALV. STEEL, PER ENTERGY DWG TMM060A
2	2	-	BOLT, MACHINE, 1/2"-13 X 1", ALL THREAD, GALV. STEEL, NO NUT, NO WASHER (ANY SUPPLIER)
-	-	-	-
-	-	-	-
-	-	-	-

NOTE #1: ASSEMBLY WILL TYPICALLY BE Banded TO POLE USING 3/4" SS BAND MATERIAL AND ADAPTERS SUPPLIED WITH THE SPLICE BOX. ALTERNATELY, THE COIL BRACKET ASSEMBLY MAY BE SECURED WITH TWO 1/2" BOLTS (ITEM 2) USING ANY TWO OF THE FOUR THREADED RECEIVER PROVIDED.

NOTE #2: COIL BRACKET ASSEMBLY CAN BE INSTALLED WITH EITHER END UP. BEFORE TIGHTENING BOLTS, BE SURE THAT WEIGHT OF COMPONENTS PULLS THEM FIRMLY INTO SLOTTED HOLES IN THE CHANNEL.

NOTE #3: THE LOWEST PART OF THE INSTALLATION MUST BE A MINIMUM OF 15 FEET ABOVE GROUNDLINE AND THE CABLE MUST COME INTO THE BOTTOM OF THE SPLICE BOX WITH NO STRAIN ON THE CONNECTORS. ADDITIONAL BANDING MAY BE NECESSARY TO GATHER AND STABILIZE THE EXCESS CABLE LENGTH TO THE BRACKET AND POLE. HOLES ARE PROVIDED IN THE END OF EACH ARM TO ACCOMMODATE CABLE TIES OR WIRE TIES.

15' MINIMUM ABOVE GL. IF ALTERNATE SPICE BOX LOCATION IS USED, NO PART OF INSTALLATION CAN BE LOWER THAN 15' ABOVE THE GROUND LINE.

CB-OP-C

ENTERGY SERVICES, INC.

Transmission Line Design Standard

COIL BRACKET, OPGW, CONCRETE POLE

STRUCTURAL ASSEMBLY DETAIL

STD NO.	SCALE: NONE
No. TMD387A3	
PLOT 1=1 SH. 1 OF 1	

3	9-24-15	ADD REF. LINE FOR 15' MIN. DIMENSION	ECW	ECW	
2	8-21-14	REV NOTE 1, DEL ITEM 3 & NOTE 2, RENUM NOTES	ECW	WLS	
1	5-15-07	REVISED NAME & DESCRIPTION	TWF	HSK	HSK
0	3-30-06	CREATED	RMB	HSK	HSK
NO.	DATE:	REVISION	BY:	CHK:	APPR:

EWILL12
8/24/15
CB-OP-C

Appendix 2: High Voltage Overhead Transmission

Attachment 1: APPLICABLE STANDARD FRAMING AND ASSEMBLY DRAWINGS

BILL OF MATERIALS			
GROUND, DEADEND, OPGW, CONCRETE POLE			
ITEM	QTY.	STOCK NO.	DESCRIPTION
1	1	0032033755	JUMPER, STATIC LINE: MULTI-STRANDED TINNED COPPER, 133/.0177, 48" LG, W/TERMINALS

NOTE: ITEM 1 CAN BE MADE UP WITH 48" OF THE WIRE (0032018798) AND TWO TERMINALS (0032031548) AND COMPRESSING THE TERMINALS WITH AN INDENT DIE.

GND-DE-OP-C

ENTERGY SERVICES, INC.	
Transmission LineDesign Standard GROUND, DEADEND, OPGW, CONCRETE POLE STRUCTURAL ASSEMBLY DETAIL	
STD NO.	SCALE: NONE
No. TMD398A0	
PLOT 1=1 SH. 1 OF 1	

0	5-15-07	CREATED	TWF	HSK	HSK
NO.	DATE	REVISION	BY:	CHK:	APPR:
	tfinc90	5/31/2007			

GND-DE-OP-C

TEMP:\AM-Work\willi2\1M-LITAPETSP047.D-TDdocs\S-Template\ESI\STANDARD\STTransmission\AMISC\TMD398A0.dwg, 5/25/2010 1:22:27 PM, ewilliz

Appendix 2: High Voltage Overhead Transmission

Attachment 1: APPLICABLE STANDARD FRAMING AND ASSEMBLY DRAWINGS

BILL OF MATERIALS			
GROUND, SUSP. 30-50° w/YOKE, OPGW, STEEL POLE			
ITEM	QTY.	STOCK NO.	DESCRIPTION
1	2	0032033755	JUMPER, STATIC LINE: MULTI-STRANDED TINNED COPPER, 133/.0177, 48" LG, W/TERMINALS
2	2	0000018450	ASSEMBLY, BOLT: MACH, SS, HEX HEAD, 1/2" DIA. X 1" LG., WITH NUT, 2 WASHERS AND 1 BELLEVILLE WASHER

NOTE: ITEM 1 CAN BE MADE UP WITH 48" OF THE WIRE (0032018798) AND TWO TERMINALS (0032031548) AND COMPRESSING THE TERMINALS WITH AN INDENT DIE.
NOTE: ITEM 2 HAS 1 NUT AND 1 WASHER THAT WILL NOT BE NEEDED.

THIS VIEW REVOLVED FOR CLARITY

THIS DRAWING REPLACES: TMD343B1
GND-SUY-OP-S

ENTERGY SERVICES, INC.			
Transmission LineDesign Standard GROUND, SUSP. 30-50, W/YOKE, OPGW, STEEL POLE STRUCTURAL ASSEMBLY DETAIL			
STD NO.	SCALE: NONE		
		No. TMD399A0	
0	5-15-07	CREATED	
NO.	DATE:	REVISION	
	tfinc90	5/31/2007	
		TWF	HSK HSK
		BY:	CHK: APPR:
		PLOT	1=1 SH. 1 OF 1
GND-SUY-OP-S			

TEMP:\AM-Work\ewillii\2M-LITAPETSP047.D-TDdocs-S-Template\ESI\STANDARD\STTransmission\AMISC\TMD399A0.dwg, 5/28/2010 3:09:52 PM, ewillii2

Appendix 2: High Voltage Overhead Transmission

Attachment 1: APPLICABLE STANDARD FRAMING AND ASSEMBLY DRAWINGS

BILL OF MATERIALS			
GROUND, DEADEND, OPGW, STEEL POLE			
ITEM	QTY.	STOCK NO.	DESCRIPTION
1	1	0032033755	JUMPER, STATIC LINE: MULTI-STRANDED TINNED COPPER, 133/.0177, 48" LG, W/TERMINALS
2	1	0000018450	ASSEMBLY, BOLT: MACH, SS, HEX HEAD, 1/2" DIA. X 1" LG., WITH NUT, 2 WASHERS AND 1 BELLEVILLE WASHER

NOTE: ITEM 1 CAN BE MADE UP WITH 48" OF THE WIRE (0032018798) AND TWO TERMINALS (0032031548) AND COMPRESSING THE TERMINALS WITH AN INDENT DIE.
NOTE: ITEM 2 HAS 1 NUT AND 1 WASHER THAT WILL NOT BE NEEDED.

BOLT COMES WITH DEADEND BODY

48" JUMPER LENGTH

THIS DRAWING REPLACES: TMD343C1
GND-DE-OP-S

ENTERGY SERVICES, INC.	
Transmission Line Design Standard GROUND, DEADEND, OPGW, STEEL POLE STRUCTURAL ASSEMBLY DETAIL	
STD NO.	SCALE: NONE
No. TMD402A0	
PLOT 1=1	SH. 1 OF 1

0	5-15-07	CREATED	TWF	HSK	HSK
NO.	DATE	REVISION	BY:	CHK:	APPR:
	tfinc90	5/31/2007			

GND-DE-OP-S

TEMP:\AM-Work\ewillii\2M-LITAPETSP047.D-TDdocs-S-Template\ESI\STANDARD\STTransmission\AMISC\TMD402A0.dwg, 5/25/2010 1:27:23 PM, ewillii2

Appendix 2: High Voltage Overhead Transmission

Attachment 1: APPLICABLE STANDARD FRAMING AND ASSEMBLY DRAWINGS

LIST OF COMPONENTS							
QUAN ASSY	ITEM NO.	DESCRIPTION	CATALOG NUMBER	ULTIMATE STRENGTH	BASIC MATERIAL	WEIGHT EACH	ENERGY STOCK NO.
2	(1)	ANCHOR SHACKLE	ASH-66A	50,000 #	F.S.	2.25 #	EN000491
1	(2)	COMPRESSION D.E.	*SEE TABLE*	-	ALUM.		*SEE TABLE*
1	(3)	TERMINAL	*SEE TABLE*	-	ALUM.		*SEE TABLE*
2	(4)	SHACKLE	J732	12,400#	F.S.	1.46#	**
1	(5)	INSULATOR	L506	20,000#	PORC.	2.90#	**
4	(6)	CLIPPED WASHER	ASM-7159-1		SIL		**
<p>** ITEMS 4, 5 & 6 ARE COMBINED INTO ENERGY STOCK CODE 000125-308. INDUS CAT ID 000125-308 LISTS THESE ITEMS AS ONE MACLEAN PART NUMBER XXXXXXXXXXXXXXX.</p> <p style="text-align: center;">FOR COMPRESSION DEAD END</p>							
SHIELD WIRE	SHIELD WIRE DIA.	COMP. D.E. (ITEM 2)	ENERGY STOCK NO.	TERMINAL (ITEM 3)	ENERGY STOCK NO.	ASSEMBLY CAT. NO.	
7 NO. 7 ALUMOWELD	0.433	V3816.484T	EN005526	3916.484	EN028530	C-7687-OGWDE1-2	
3/8" EHS STEEL	0.375	V3814.386T	EN005530	3914.386	EN028531	C-7687-OGWDE2-2	
7/16" EHS STEEL	0.438	V3816.453T	EN005531	3914.386	EN028531	C-7687-OGWDE4-2	

GENERAL NOTES
THESE INSULATED SHIELD WIRE ASSEMBLIES ARE PRIMARILY FOR SELECT LINES OF THE 500KV SYSTEM WHERE POWER LOSSES ARE A CONCERN. THERE MAY BE OTHER APPLICATIONS ON THE LOWER VOLTAGE LINES WHERE RADIO INTERFERENCE IS A CONCERN.

OHG-DEJB-XX

ENERGY SERVICES, INC.	
Transmission LineDesign Standard OVERHEAD GROUNDWIRE DEADEND ASSY STRUCTURAL ASSEMBLY DETAIL	
STD NO.	SCALE: NONE
No. TMD403A0	
PLOT 1=1	SH.1 OF 1

0	12-13-07	CREATED	TWF	HSK	HSK		No. TMD403A0 PLOT 1=1 SH.1 OF 1 OHG-DEJB-XX
ND.	DATE:	REVISION	BY:	CHK:	APPR		

tfinc90 12/20/2007

TEMP:\AM-Work\willi2\1M-LITAP\ETSP047.D-TDdocs\S-Template\ESI\STANDARD\STTransmission\AMISC\TMD403A0.dwg, 5/28/2010 5:05:01 PM, ewilliz

Appendix 2: High Voltage Overhead Transmission

Attachment 1: APPLICABLE STANDARD FRAMING AND ASSEMBLY DRAWINGS

REVISIONS		DESIGN APPROVAL	
NO.	DATE	BY	DATE
1	3/27/81	ES	
2	3/28/81	ES	
3	4/17/81	ES	
4	6/6/81	ES	
5	8/14/81	ES	
6	11/13/81	ES	
7	11/13/81	ES	
8	2/15/82	ES	
9	7/8/82	ES	

LIST OF COMPONENTS			
QTY/ASSY	ITEM NO.	DESCRIPTION	CATALOG NUMBER
1	1	7-CLEVIS BALL	YCB-65A
1	2	SUSPENSION CLAMP	*SEE TABLE*
1	3	ARMOR ROD	AWAR-1080

SHIELD WIRE	SHIELD WIRE DIA.	CLAMP (ITEM 2)	ENERGY STOCK NO.	ASSEMBLY CAT. NO.
7 NO. 7 ALUMOWELD	0.433	LS-1-S	EN000392	C-7687-0GWS1
3/8" EHS	0.375	FSC-60-S	EN000377	C-7687-0GWS1A

*LS-1 MATERIAL IS AL. & ULT. STR. 18,000 LBS. WT. 4.11 LBS.
 FSC-60 MATERIAL IS D.I. & ULT. STR. 17,000 LBS. WT. 4.00 LBS.

ASSEMBLY C-7687-0GWS1

ASSEMBLY C-7687-0GWS1A

REF. DWG. NO. BC7687-0 FOR MATERIAL NOTES
 ALL DIMENSIONS IN INCHES

DESIGN APPROVAL	STANDARDS APPROVAL	OHG-SUS-XX	BETHEA POWER PRODUCTS
SIGNED / DATE	SIGNED / DATE		PLUMAS, ALABAMA
ESI NO. TMD223A4			OVERHEAD GROUNDWIRE
ENERGY NO. OHGSUS			SUSPENSION ASSEMBLY
			BC-687

Appendix 2: High Voltage Overhead Transmission

Attachment 1: APPLICABLE STANDARD FRAMING AND ASSEMBLY DRAWINGS

REVISIONS		DESIGN APPROVAL		LIST OF COMPONENTS								
NO.	DATE	BY	CHKD BY	DATE	QTY	ITEM NO.	DESCRIPTION	CATALOG NUMBER	ULTIMATE STRENGTH	BASIC MATERIAL	WEIGHT EACH	ENTERY STOCK NO.
1	3/22/01	SKL	REVISIONS									
2	4/11/01	SKL	ADDED STOCK NTS									
3	3/22/01	SKL	CHANGED COMPRESSION FOR 3/4"									
4	3/22/01	SKL	CHANGED COMPRESSION FOR 3/4"									
5	11/14/01	SKL	REVISIONS									
6	10/2/01	SKL	REVISIONS									
7	10/2/01	SKL	REVISIONS									
8	3/4/02	SKL	ADDED ASSY DRAWING									

FOR COMPRESSION DEAD END			
SHIELD WIRE	SHIELD WIRE DIA.	COMP. D.E. (ITEM 2)	ENTERY STOCK NO.
7 NO. 7 ALUMINUM WELD	0.433	V816.4841	EN005526
3/8" EHS STEEL	0.375	V814.3861	EN005530
7/16" EHS STEEL	0.438	V816.4531	EN005531

FOR COMPRESSION DEAD END			
TERMINAL (ITEM 3)	ENTERY STOCK NO.	ASSEMBLY CAT. NO.	
3916.484	EN028530	C-7687-00WDE1	
3914.386	EN028531	C-7687-00WDE2	
3914.386	EN028531	C-7687-00WDE4	

LIST OF COMPONENTS	
QTY	ITEM NO.
1	(1) ANCHOR SHACKLE
1	(2) Y-CLEVIS BALL
1	(3) STRAIN CLAMP

LIST OF COMPONENTS	
QTY	ITEM NO.
1	(1) ANCHOR SHACKLE
1	(2) Y-CLEVIS BALL
1	(3) STRAIN CLAMP

DESIGN APPROVAL: OHG-DE-XX

STANDARD APPROVAL: _____

SIGNED: _____ / DATE: _____

EST. NO. TMD222A4

ENTERY NO. OHGDE

BETHEA POWER PRODUCTS
PUNTA, ALABAMA

OVERHEAD GROUNDWIRE
DEADEND ASSEMBLY

BC-7687

ALL DIMENSIONS IN INCHES
SEE SHEET ONE FOR MATERIAL NOTES

ASSEMBLY NUMBER C-7687-00WDE3

Appendix 2: High Voltage Overhead Transmission

Attachment 1: APPLICABLE STANDARD FRAMING AND ASSEMBLY DRAWINGS

MPS REVISIONS		DATE APPROVAL	
NO.	DATE	BY	DATE

LIST OF COMPONENTS						
QUAN	ITEM	DESCRIPTION	CATALOG NUMBER	BASIC MATERIAL	WEIGHT EACH	ENTERY STOCK NO.
2	(1)	ANCHOR SHACKLE	ASH-65A	F.S.	2.25	EN000481
1	(2)	COMPRESSION D.E.	*SEE TABLE*	ALUM.	—	*SEE TABLE*
1	(3)	TERMINAL	J732	ALUM.	—	*SEE TABLE*
2	(4)	SHACKLE	L506	F.S.	1.46	EN000481
1	(5)	INSULATOR	ASM-7159-1	PORC.	2.90	EN000481
4	(6)	CLIPPED WASHER	ASM-7159-1	STL.	—	EN000481

FOR COMPRESSION DEAD END			
SHIELD WIRE	SHIELD WIRE DIA. (COMP. D.E.)	ENTERY STOCK NO.	TERMINAL (ITEM 3)
7 NO. 7 ALUMINUM WELD	0.433	V3816.484T	EN005526
3/8" EHS STEEL	0.375	V3814.386T	EN005530
7/16" EHS STEEL	0.438	V3816.453T	EN005531

REF. DWG. NO. BC7687-0 FOR MATERIAL NOTES
ALL DIMENSIONS IN INCHES

ENERGY REV. A	REVISION DATE 10/12/07
ESI NO.	

This drawing contains confidential information that is the property of Nuclear Power Systems, LLC. (Nuclear). Use of Nuclear's confidential information without Nuclear's express written consent is strictly prohibited and may expose you to legal liability. If you believe you have received this drawing in error, please notify it or return it to Nuclear Power Systems, LLC, 11617 Hudson Street, Fremont, CA, 94538, USA.

NUCLEAR POWER SYSTEMS A Technomic Company	OVERHEAD GROUNDWIRE DEADEND ASSEMBLY
BC-7687-4	10/12/07

Appendix 2: High Voltage Overhead Transmission

Attachment 1: APPLICABLE STANDARD FRAMING AND ASSEMBLY DRAWINGS

BILL OF MATERIALS

INSULATOR, 2-1/2" POLYMER BRACED LINE POST ASSY FOR 161KV

ITEM	QUANTITY	STOCK NO.	DESCRIPTION	CATALOG NUMBER	BASIC MATERIAL	WEIGHT (LBS)	ULTIMATE STRENGTH (LBS)
1	1	EN004375	BALL GLEWS, 45 DEG Y, 3/8" U.L.T., 3/4" PIN DIA	YCB-85A	F.S.	2.2	35,000
2	1	EN016149	INSULATOR, 2-1/2" BRACED POST ASSY, POLYMER, HIGH POL. 161KV	B201076AL46A	COMP.	101.3	SEE APP. CURVE
3	1	LS9003XX	ROD, ARMOR, PREFORMED, ALUMINUM, VARIABLE CONDUCTOR SIZE	SEE TABLE	ALUM.	VARIES	N/A
4	1	LS9003XX	CLAMP, SUSPENSION, ALUMINUM, VARIABLE WIRE SIZE, W/SOCKET EYE	SEE TABLE	AL./D.I.	VARIES	25,000 U.N.O.
5	1	32103543	CHAIN, STL., GALVANIZED, 1.78 LBS/FT., 72-4K U.L.T.	CH578-14LK	F.S.	4.2	72,400
6	1	LS915XX	YOKK, VERTICAL DOUBLE BUNDLE, VARIABLE SIZE WIRE	SEE TABLE	AL./D.I.	VARIES	25,000 *
7	1	EN018718	Y-CLEWS-CLEVIS (SUPPLIED AS PART OF ITEM 2)	YCC-65	D.I.	1.4	30,000
8	1	EN014659	INSULATOR, SUSPENSION (SUPPLIED AS PART OF ITEM 2)	S146073VA12	COMP.	16.5	25,000
9	1	EN018719	SOCKET GLEWS H. L. (SUPPLIED AS PART OF ITEM 2)	SCHL-55	D.I.	3.3	30,000
10	1	EN014653	INSULATOR, POST (SUPPLIED AS PART OF ITEM 2)	H201076V18	COMP.	75.2	SEE APP. CURVE
11	1	EN020881	RING, CORONA (SUPPLIED AS PART OF ITEM 2)	CR16/18-8	ALUM.	4.0	N/A

* ULTIMATE STRENGTH FOR BUNDLING YOKE IS AS AN ASSEMBLY

FOR SINGLE CONDUCTORS (BP2)				FOR BUNDLED CONDUCTORS (BP2B)			
CONDUCTOR	ARMOR ROD (ITEM 3)	ENERGY W/ ARM. (ITEM 4)	TAKEOFF ANGLE (DEG)	CLAMP (ITEM 4)	ENERGY STOCK NO.	ASSEMBLY CATALOG NO.	ENERGY STOCK NO.
1949 (35/1), LAPWING	AR-0163	EN0001361	2,376	TL5-0195E **	32068987	NOT YET ASSIGNED	N/A
1592 (33/1), BITTERN	AR-0146	EN0001355	2,075	TL5-0115E **	32068982	NOT YET ASSIGNED	N/A
1428 (33/1), BEAUMONT	AR-0137	EN000384	1,620	AGS-5138	32062067	NOT YET ASSIGNED	N/A
1222 (33/1), CARDINAL	AR-0165	EN000382	2,474	TL5-0115E	32068988	NOT YET ASSIGNED	N/A
821 (18/1), GROSSEAK	AR-0163	EN0001361	2,376	TL5-0105E	32068975	NOT YET ASSIGNED	N/A
1590 (45/7), LAPWING	AR-0163	EN0001361	2,376	AGS-244-20-20-S	32027631	NOT YET ASSIGNED	N/A
1272 (45/7), BITTERN	AR-0146	EN0001355	2,075	AGS-214-20-20-S	32027618	NOT YET ASSIGNED	N/A
954 (54/7), CROWLAN	AR-0143	EN000383	1,816	AGS-188-20-20-S	32027616	NOT YET ASSIGNED	N/A
665.6 (24/7), FLAMINGO	AR-0137	EN000384	1,620	AGS-175-20-20-S	32027614	NOT YET ASSIGNED	N/A
1780 (84/19), CHUKAR	AR-0165	EN000382	2,474	ASC-11-S	EN0004361	C-7648-BP2-6	EN027828
1590 (45/7), LAPWING	AR-0163	EN0001361	2,376	ASC-11-S	EN0004361	C-7648-BP2-4	EN027828
1272 (45/7), BITTERN	AR-0146	EN0001355	2,075	ASC-11-S	EN0004361	C-7648-BP2-4	EN027828
1033.5 (45/7), ORTOLAN	AR-0144	EN027807	1,943	LS-9-S	EN027859	C-7648-BP2-8	EN027825
954 (54/7), CROWLAN	AR-0143	EN000383	1,816	LS-8-S	EN000370	C-7648-BP2-3	EN027825
795 (26/7), DRAKE	AR-0141	EN004005	1,728	LS-8-S	EN000370	C-7648-BP2-3	EN027825
665.6 (24/7), FLAMINGO	AR-0137	EN000384	1,620	LS-8-S	EN000370	C-7648-BP2-3	EN027825
336.4 (26/7), LINNET	AR-0130	EN000385	1,129	LS-6-S	EN000156	C-7648-BP2-3	EN027823
1024.5 24/13	AR-0143	EN000383	1,785	LS-6-S	EN000370	C-7648-BP2-3	EN027825
649.5 18/19	AR-0135	EN027866	1,428	LS-6-S	EN000156	C-7648-BP2-3	EN027823
395.2 15/7	AR-0130	EN000385	1,129	LS-6-S	EN000156	C-7648-BP2-3	EN027823

** ULTIMATE STRENGTH FOR TL5-0115E & TL5-0195E IS 30k

MIN. ELECTRICAL SPECIFICATIONS

MIN. ELECTRICAL VALUES
60 HZ DRY FO 590 KV
60 HZ WET FO 510 KV
CFO+ 960 KV
CFO- 1020 KV
STROKE DIST 60 IN
LEAKAGE DIST 140 IN

MIN. MECHANICAL STRENGTH

MODEL	SUBMIT CURVES
-------	---------------

NOTES

- Item #3, #4 and #6 are conductor dependent. Comps/Bundles are selected for each project and are Applied with Armor Rod, unless specifically noted.
- For Braced Post, individual part details see Insulator Mfg. drawings.
- Note that 161 kV insulators are used for 115 & 138 kV applications.
- Stock Code shown is for Pre-Cut Chain. Alternately, cut 14 links from EN018717.
- For Hardware Only, add suffix "-H" to Assembly Cat. No. Ex: C-7648-BP2-1-H

ENTERGY SERVICES, INC.

TRANSMISSION LINE STANDARD

POLYMER ASSY, 2 1/2" BRACED POST
161 KV INSULATOR ASSEMBLY DETAIL

No. TCA200A11

No. TCA200A11

PLOT 1:24 SH-1 DF-1

Appendix 2: High Voltage Overhead Transmission

Attachment 1: APPLICABLE STANDARD FRAMING AND ASSEMBLY DRAWINGS

BILL OF MATERIALS

INSULATOR, DEADEND, POLYMER WITH TURNBUCKLE, 161KV

ITEM DE2 DE4	QUANTITY	DE2 DE4 STOCK NO.	DESCRIPTION	CATALOG NUMBER	BASIC MATERIAL E.A. (LBS)	WEIGHT (LBS)	ULTIMATE STR. (LBS)
1	1	EN015705	SKT. CLEVIS, HOT LINE, 45 DEG Y, 10-15/16" LONG, 50K ULT, 7/8" PIN	SYCHL-87	D.I.	3.45	50,000
2	1	EN014810	INSULATOR, DE, POLYMER, HIGH POLLUTION, 50K LB SML, 161KV	S298092VA10	COMP.	23.3	50,000
3	1	EN015176	LINK, EXTENSION, CLEVIS-CLEVIS, 15" C-C, 50K ULT	YCYCHL-77	D.I.	10.0	50,000
4	1	LS9004XX	TERMINAL CONNECTOR, 15 DEG, FOR VARIABLE SIZE WIRE	SEE TABLE	ALUM.	VARIES	-
5	1	LS9003XX	DEADEND, ALUM. COMP. BODY, SINGLE TONGUE, FOR VAR. SIZE WIRE	SEE TABLE	ALUM.	VARIES	-
6	1	LS913XX	DEADEND BOLTED STRAIN ALUM. ALLOY	SEE TABLE	ALUM.	VARIES *	-
7	1	LS9209	JUMPER SPRUCE (NOT INCLUDED WITH ASSEMBLY)	SEE TABLE	-	-	-
8	1	EN015815	TURNBUCKLE, 1" x 6", JAW-EYE	G227N-BC-1x6	F.S.	9.2	50,000
9	-	-	-	-	-	-	-
10	-	-	-	-	-	-	-
11	-	-	-	-	-	-	-
12	-	-	-	-	-	-	-
13	-	-	-	-	-	-	-
14	-	-	-	-	-	-	-
15	0	EN020683	RING, CORONA (SUPPLIED WITH ITEM 2)	CR24/32-8	ALUM.	5.0	N/A
16	0	NOTE 3	COMPOUND, ELECTRICAL FILLER	NOTE 3	-	-	N/A
17	0.5	NOTE 4	COMPOUND, ELECTRICAL JOINT	NOTE 4	-	-	N/A

FOR COMPRESSION ASSEMBLY (DE2)

CONDUCTOR	DIA. (IN)	COMP. DE (ITEM 5)	ENERGY STOCK NO.	TERMINAL (ITEM 4)	ENERGY STOCK NO.	ASSEMBLY CATALOG NO.	STRAIN CLAMP (ITEM 6)	ENTERY STOCK NO.	ASSEMBLY CATALOG NO.
1949.0 (56/7), LAPWING	1.504	5600-1090NT	32181747	600-353-1	32181749	NOT YET ASSIGNED	N/A	N/A	N/A
1562.0 (33/7), BITTERN	1.345	5600-1080NT	32069426	600-253-1	32069448	NOT YET ASSIGNED	N/A	N/A	N/A
1428.5 (33/7), BEAUMONT	1.294	5600-1078NT	32118745	600-253-9	3201160	NOT YET ASSIGNED	N/A	N/A	N/A
1222.0 (33/7), CARDINAL	1.198	5600-1070NT	32069424	600-253-7	32069447	NOT YET ASSIGNED	N/A	N/A	N/A
821.2 (15/7), GROSBEAK	0.990	5600-1050NT	32069419	600-153-7	32069445	NOT YET ASSIGNED	N/A	N/A	N/A
1590.0 (45/7), LAPWING	1.504	E33173HT-NT	32020679	5140.152HT-SS	32020659	C-8083-DE2-4	N/A	N/A	N/A
1272.0 (45/7), BITTERN	1.345	E33161HT-NT	32020677	5136.144HT-SS	32020420	C-8083-DE2-3	N/A	N/A	N/A
954.0 (54/7), CARDINAL	1.196	E33150HT-NT	32019804	5130.125HT-SS	32019813	C-8083-DE2-2	N/A	N/A	N/A
1786.0 (84/7), CHUKAR	1.602	VES-174-NT	32020675	5127.109HT-SS	32020419	C-8083-DE2-1	N/A	N/A	N/A
1590.0 (45/7), LAPWING	1.504	VES-164-NT	EN004276	IF-17-SS	EN004445	C-7648-DE2-7	ADE-27-GE-S8	EN005957	C-7648-DE4-4
1272.0 (45/7), BITTERN	1.345	VES-153-NT	EN000161	IF-18-SS	EN000164	C-7648-DE2-6	ADE-27-S8	EN005721	C-7648-DE4-2
954.0 (54/7), CARDINAL	1.196	VES-134-NT	32009718	IF-13-SS	EN004447	C-7648-DE2-13	ADE-2526-S8	EN006015	C-7648-DE4-1
954.0 (45/7), RAIL	1.165	VES-135-NT	EN004083	IF-13-SS	EN004447	C-7648-DE2-4	ADE-2526-S8	EN006015	C-7648-DE4-1
795.0 (26/7), DRAKE	1.108	VES-132-NT	EN004352	IF-13-SS	EN004447	C-7648-DE2-3	ADE-2526-S8	EN006015	C-7648-DE4-1
666.6 (24/7), FLAMINGO	1.000	VES-115-NT	EN002768	IF-12-SS	EN027977	C-7648-DE2-8	ADE-2526-S8	EN006015	C-7648-DE4-1
336.4 (26/7), LINNET	0.720	VES-086-NT	EN004278	IF-08-SS	EN004448	C-7648-DE2-2	ADE-2526-S8	EN006015	C-7648-DE4-3
1024.5 (24/13)	1.165	VES-130-NT	EN027818	IF-13-SS	EN004447	C-7648-DE2-12	ADE-2526-S8	EN006015	C-7648-DE4-1
846.5 (18/7)	0.928	VES-100-NT	EN027817	IF-10-SS	EN027819	C-7648-DE2-11	ADE-2526-S8	EN006015	C-7648-DE4-1
355.2 (15/7)	0.720	VES-080-NT	EN027816	IF-08-SS	EN004449	C-7648-DE2-10	ADE-24-S8	EN005298	C-7648-DE4-3

BOLTED ASSEMBLY

ALTERNATE PARTS NOT PERMITTED FOR ACCS & ACCC (SEE NOTE 2)

COMPRESSION ASSEMBLY

JUMPER CONNECTION (NOT INCL. WITH ASSY.)

FOR BOLTED ASSEMBLY (DE4)

CONDUCTOR	DIA. (IN)	COMP. DE (ITEM 5)	ENERGY STOCK NO.	TERMINAL (ITEM 4)	ENERGY STOCK NO.	ASSEMBLY CATALOG NO.	STRAIN CLAMP (ITEM 6)	ENTERY STOCK NO.	ASSEMBLY CATALOG NO.
1949.0 (56/7), LAPWING	1.504	5600-1090NT	32181747	600-353-1	32181749	NOT YET ASSIGNED	N/A	N/A	N/A
1562.0 (33/7), BITTERN	1.345	5600-1080NT	32069426	600-253-1	32069448	NOT YET ASSIGNED	N/A	N/A	N/A
1428.5 (33/7), BEAUMONT	1.294	5600-1078NT	32118745	600-253-9	3201160	NOT YET ASSIGNED	N/A	N/A	N/A
1222.0 (33/7), CARDINAL	1.198	5600-1070NT	32069424	600-253-7	32069447	NOT YET ASSIGNED	N/A	N/A	N/A
821.2 (15/7), GROSBEAK	0.990	5600-1050NT	32069419	600-153-7	32069445	NOT YET ASSIGNED	N/A	N/A	N/A
1590.0 (45/7), LAPWING	1.504	E33173HT-NT	32020679	5140.152HT-SS	32020659	C-8083-DE2-4	N/A	N/A	N/A
1272.0 (45/7), BITTERN	1.345	E33161HT-NT	32020677	5136.144HT-SS	32020420	C-8083-DE2-3	N/A	N/A	N/A
954.0 (54/7), CARDINAL	1.196	E33150HT-NT	32019804	5130.125HT-SS	32019813	C-8083-DE2-2	N/A	N/A	N/A
1786.0 (84/7), CHUKAR	1.602	VES-174-NT	32020675	5127.109HT-SS	32020419	C-8083-DE2-1	N/A	N/A	N/A
1590.0 (45/7), LAPWING	1.504	VES-164-NT	EN004276	IF-17-SS	EN004445	C-7648-DE2-7	ADE-27-GE-S8	EN005957	C-7648-DE4-4
1272.0 (45/7), BITTERN	1.345	VES-153-NT	EN000161	IF-18-SS	EN000164	C-7648-DE2-6	ADE-27-S8	EN005721	C-7648-DE4-2
954.0 (54/7), CARDINAL	1.196	VES-134-NT	32009718	IF-13-SS	EN004447	C-7648-DE2-13	ADE-2526-S8	EN006015	C-7648-DE4-1
954.0 (45/7), RAIL	1.165	VES-135-NT	EN004083	IF-13-SS	EN004447	C-7648-DE2-4	ADE-2526-S8	EN006015	C-7648-DE4-1
795.0 (26/7), DRAKE	1.108	VES-132-NT	EN004352	IF-13-SS	EN004447	C-7648-DE2-3	ADE-2526-S8	EN006015	C-7648-DE4-1
666.6 (24/7), FLAMINGO	1.000	VES-115-NT	EN002768	IF-12-SS	EN027977	C-7648-DE2-8	ADE-2526-S8	EN006015	C-7648-DE4-1
336.4 (26/7), LINNET	0.720	VES-086-NT	EN004278	IF-08-SS	EN004448	C-7648-DE2-2	ADE-2526-S8	EN006015	C-7648-DE4-3
1024.5 (24/13)	1.165	VES-130-NT	EN027818	IF-13-SS	EN004447	C-7648-DE2-12	ADE-2526-S8	EN006015	C-7648-DE4-1
846.5 (18/7)	0.928	VES-100-NT	EN027817	IF-10-SS	EN027819	C-7648-DE2-11	ADE-2526-S8	EN006015	C-7648-DE4-1
355.2 (15/7)	0.720	VES-080-NT	EN027816	IF-08-SS	EN004449	C-7648-DE2-10	ADE-24-S8	EN005298	C-7648-DE4-3

MIN. ELECTRICAL VALUES

60 HZ DRY FO	600 KV
60 HZ WET FO	625 KV
CF0+	1215 KV
CF0-	1275 KV
DRY ARC DIST.	75 IN.
LEAKAGE DIST.	180 IN.
MIN. MECHANICAL STRENGTH	
ULT.	50,000 LBS

MIN. ELEC. MECH. SPECIFICATIONS

NO.	DATE:	REVISION	BY:	CHK:	APPR:
1	12-31-14	ADDED ELEC. SPEC. & COND. HARDWARE TABLE, RE-DRAWN T107	EN	JM	MS
2	05-25-11	ADDED CORONA RING, UPDATE ITEM 2 RESC.	CSM	EN	EW
3	10-14-04	MODIFIED MATERIAL	RMB		
4	11-29-00	ADDED (I-NUM) TO NAME	RMB		
5	06-00-00	ADDED A.L.T. PARTS	LFT		
6		DRAWING CREATED	RMB		

ENERGY SERVICES, INC.

TRANSMISSION LINE STANDARD

POLYMER ASST., DEADEND W/ TURNBUCKLE

161 KV INSULATOR ASSEMBLY DETAIL

STD NO. TA0504 SCALE: N. T. S.

No. TCA205A5

Plot 1:24 SH.1 DF.1

Appendix 2: High Voltage Overhead Transmission

Attachment 1: APPLICABLE STANDARD FRAMING AND ASSEMBLY DRAWINGS

BILL OF MATERIALS									
INSULATOR, 2-1/2" POLYMER JUMPER LINE POST ASSY FOR 161 kV									
ITEM	QTY	U.P.	STOCK NO.	DESCRIPTION	CATALOG NUMBER	BASIC MATERIAL	WEIGHT (LBS)	ULTIMATE STRENGTH (LBS)	ULTIMATE STRENGTH (LBS)
1	1	1	EN004375	BALL CLEVIS, 45 DEG Y, 3/8" U.L.T., 3/4" PIN DIA	YCB-85A	F.S.	2.2	35,000	35,000
2	1	1	32094117	INSULATOR, 2-1/2" POST, POLYMER, HIGH POL., 161 kV	H29107EVA04	COMP.	80.2	SEE APP. CURVE	SEE APP. CURVE
3	1	2	LS9003XX	ROD, ARMOR, PREFORMED, ALUMINUM, VARIABLE CONDUCTOR SIZE	SEE TABLE	AL/D.I.	VARIES	VARIES	N/A
4	1	1	LS9008XX	CLAMP, SUSPENSION, ALUMINUM, VARIABLE WIRE SIZE, W/SOCKET EYE	SEE TABLE	AL/D.I.	VARIES	25,000 U.N.O.	25,000 U.N.O.
5	1	1	LS915XX	YOKER, VERTICAL DOUBLE BUNDLE, VARIABLE SIZE WIRE	SEE TABLE	AL/D.I.	VARIES	25,000 U.N.O.	25,000 U.N.O.
6	1	1	32093707	RING, CORONA (SUPPLIED WITH ITEM 2.)	LP25CR6	ALUM.	5.0	N/A	N/A

FOR SINGLE CONDUCTORS (J.P)									
CONDUCTOR	ARMOR ROD (ITEM 3)	ENTERY STK. NO.	TAKEOFF ANGLE (DEG)	CLAMP (ITEM 4)	ENTERY STOCK NO.	ASSEMBLY CATALOG NO.	BUNDLE (ITEM 5)	ENTERY STOCK NO.	ASSEMBLY CATALOG NO.
1948 (56/7), LAPWING	INCL. W/ ITEM 4	32068992	15	TLS-0119SE ***	32068992	NOT YET ASSIGNED	N/A	N/A	N/A
1590 (33/7), BITTERN	INCL. W/ ITEM 4	32082067	15	ACS-0138	32082067	NOT YET ASSIGNED	N/A	N/A	N/A
1420 (33/7), BEAUMONT	INCL. W/ ITEM 4	32068988	15	TLS-0115SE	32068988	NOT YET ASSIGNED	N/A	N/A	N/A
1224 (33/7), CARDINAL	INCL. W/ ITEM 4	32068975	15	TLS-0109SE	32068975	NOT YET ASSIGNED	N/A	N/A	N/A
821 (19/7), GROSBEAK	INCL. W/ ITEM 4	32068975	15	AGFS-244-20-20-S	EN028963	C-8083-ALP-3	VBAFCS-18-2442020-S	32127531	NOT YET ASSIGNED
1590 (45/7), LAPWING	AR41390-45-59	32117836	2.376	AGFS-214-20-20-S	32020718	C-8083-ALP-3	VBAFCS-18-2142020-S	32127530	NOT YET ASSIGNED
1272 (45/7), BITTERN	AR41272-45-55	32117835	2.075	AGFS-186-20-20-S	32020716	C-8083-ALP-2	VBAFCS-18-1862020-S	32127529	NOT YET ASSIGNED
954 (54/7), CARDINAL	ARA954-45-51	32117829	1.816	AGFS-175-20-20-S	32020714	C-8083-ALP-1	VBAFCS-18-1752020-S	32127527	NOT YET ASSIGNED
666.6 (24/7), FLAMINGO	ARA666-26-45	32117825	1.620	LS-8-S	EN000370	C-7648-ALP-5	VBL5-12-88-S	EN027825	C-7648-JLPB-5
1780 (84/7), CHUKAR	---	---	1.504	LS-7-S	EN000366	C-7648-ALP-4	VBL5-12-77-S	EN027824	C-7648-JLPB-4
1272 (45/7), LAPWING	---	---	1.345	LS-6-S	EN000158	C-7648-ALP-3	VBL5-12-66-S	EN027823	C-7648-JLPB-3
1033.5 (46/7), ORTOLAN	---	---	1.213	LS-6-S	EN000158	C-7648-ALP-3	VBL5-12-66-S	EN027823	C-7648-JLPB-3
954 (54/7), CARDINAL	---	---	1.196	LS-6-S	EN000158	C-7648-ALP-3	VBL5-12-66-S	EN027823	C-7648-JLPB-3
954 (45/7), RAIL	---	---	1.165	LS-6-S	EN000158	C-7648-ALP-3	VBL5-12-66-S	EN027823	C-7648-JLPB-3
795 (28/7), DRAKE	---	---	1.108	LS-6-S	EN000158	C-7648-ALP-3	VBL5-12-66-S	EN027823	C-7648-JLPB-3
666.6 (24/7), FLAMINGO	---	---	1.000	LS-2-S	EN000392	C-7648-ALP-2	VBL5-12-22-S	EN027822	C-7648-JLPB-2
336.4 (26/7), LINNET	---	---	0.720	LS-1-S ****	EN000357	C-7648-ALP-1	VBL5-12-22-S	EN027822	C-7648-JLPB-2
1024.5 24/13	---	---	1.165	LS-6-S	EN000158	C-7648-ALP-3	VBL5-12-66-S	EN027823	C-7648-JLPB-3
649.5 18/19	---	---	0.928	LS-2-S	EN000387	C-7648-ALP-2	VBL5-12-22-S	EN027822	C-7648-JLPB-2
395.2 15/17	---	---	0.720	LS-1-S ****	EN000392	C-7648-ALP-1	VBL5-12-22-S	EN027822	C-7648-JLPB-2

FOR BUNDLED CONDUCTORS (J.PB)									
CONDUCTOR	ARMOR ROD (ITEM 3)	ENTERY STK. NO.	TAKEOFF ANGLE (DEG)	CLAMP (ITEM 4)	ENTERY STOCK NO.	ASSEMBLY CATALOG NO.	BUNDLE (ITEM 5)	ENTERY STOCK NO.	ASSEMBLY CATALOG NO.
1948 (56/7), LAPWING	INCL. W/ ITEM 4	32068992	15	AGFS-244-20-20-S	EN028963	C-8083-ALP-3	VBAFCS-18-2442020-S	32127531	NOT YET ASSIGNED
1590 (33/7), BITTERN	INCL. W/ ITEM 4	32082067	15	AGFS-214-20-20-S	32020718	C-8083-ALP-3	VBAFCS-18-2142020-S	32127530	NOT YET ASSIGNED
1420 (33/7), BEAUMONT	INCL. W/ ITEM 4	32068988	15	AGFS-186-20-20-S	32020716	C-8083-ALP-2	VBAFCS-18-1862020-S	32127529	NOT YET ASSIGNED
1224 (33/7), CARDINAL	INCL. W/ ITEM 4	32068975	15	AGFS-175-20-20-S	32020714	C-8083-ALP-1	VBAFCS-18-1752020-S	32127527	NOT YET ASSIGNED
821 (19/7), GROSBEAK	INCL. W/ ITEM 4	32068975	15	LS-8-S	EN000370	C-7648-ALP-5	VBL5-12-88-S	EN027825	C-7648-JLPB-5
1590 (45/7), LAPWING	---	---	1.504	LS-7-S	EN000366	C-7648-ALP-4	VBL5-12-77-S	EN027824	C-7648-JLPB-4
1272 (45/7), BITTERN	---	---	1.345	LS-6-S	EN000158	C-7648-ALP-3	VBL5-12-66-S	EN027823	C-7648-JLPB-3
1033.5 (46/7), ORTOLAN	---	---	1.213	LS-6-S	EN000158	C-7648-ALP-3	VBL5-12-66-S	EN027823	C-7648-JLPB-3
954 (54/7), CARDINAL	---	---	1.196	LS-6-S	EN000158	C-7648-ALP-3	VBL5-12-66-S	EN027823	C-7648-JLPB-3
954 (45/7), RAIL	---	---	1.165	LS-6-S	EN000158	C-7648-ALP-3	VBL5-12-66-S	EN027823	C-7648-JLPB-3
795 (28/7), DRAKE	---	---	1.108	LS-6-S	EN000158	C-7648-ALP-3	VBL5-12-66-S	EN027823	C-7648-JLPB-3
666.6 (24/7), FLAMINGO	---	---	1.000	LS-2-S	EN000392	C-7648-ALP-2	VBL5-12-22-S	EN027822	C-7648-JLPB-2
336.4 (26/7), LINNET	---	---	0.720	LS-1-S ****	EN000357	C-7648-ALP-1	VBL5-12-22-S	EN027822	C-7648-JLPB-2
1024.5 24/13	---	---	1.165	LS-6-S	EN000158	C-7648-ALP-3	VBL5-12-66-S	EN027823	C-7648-JLPB-3
649.5 18/19	---	---	0.928	LS-2-S	EN000387	C-7648-ALP-2	VBL5-12-22-S	EN027822	C-7648-JLPB-2
395.2 15/17	---	---	0.720	LS-1-S ****	EN000392	C-7648-ALP-1	VBL5-12-22-S	EN027822	C-7648-JLPB-2

*** ULTIMATE STRENGTH FOR LS-1-S IS 16k
 *** ULTIMATE STRENGTH FOR LS-1-S IS 16k
 *** ULTIMATE STRENGTH FOR TLS-0119SE & TLS-0119SE IS 30k

MIN. ELEC./MECH. SPECIFICATIONS									
MIN. ELECTRICAL VALUES	MIN. MECHANICAL STRENGTH								
60 HZ DRY FO 590 KV	MDCL 1176 LBS.								
60 HZ WET FO 510 KV									
CIFO+ 960 KV									
CIFO- 1020 KV									
STRIKE DIST. 80 IN.									
LEAKAGE DIST. 140 IN.									

MIN. ELEC./MECH. SPECIFICATIONS									
MIN. ELECTRICAL VALUES	MIN. MECHANICAL STRENGTH								
60 HZ DRY FO 590 KV	MDCL 1176 LBS.								
60 HZ WET FO 510 KV									
CIFO+ 960 KV									
CIFO- 1020 KV									
STRIKE DIST. 80 IN.									
LEAKAGE DIST. 140 IN.									

MIN. ELECTRICAL VALUES
 60 HZ DRY FO 590 KV
 60 HZ WET FO 510 KV
 CIFO+ 960 KV
 CIFO- 1020 KV
 STRIKE DIST. 80 IN.
 LEAKAGE DIST. 140 IN.

MIN. MECHANICAL STRENGTH
 MDCL 1176 LBS.

MIN. ELEC./MECH. SPECIFICATIONS

MIN. ELECTRICAL VALUES
 60 HZ DRY FO 590 KV
 60 HZ WET FO 510 KV
 CIFO+ 960 KV
 CIFO- 1020 KV
 STRIKE DIST. 80 IN.
 LEAKAGE DIST. 140 IN.

MIN. MECHANICAL STRENGTH
 MDCL 1176 LBS.

MIN. ELEC./MECH. SPECIFICATIONS

MIN. ELECTRICAL VALUES
 60 HZ DRY FO 590 KV
 60 HZ WET FO 510 KV
 CIFO+ 960 KV
 CIFO- 1020 KV
 STRIKE DIST. 80 IN.
 LEAKAGE DIST. 140 IN.

MIN. MECHANICAL STRENGTH
 MDCL 1176 LBS.

MIN. ELEC./MECH. SPECIFICATIONS

MIN. ELECTRICAL VALUES
 60 HZ DRY FO 590 KV
 60 HZ WET FO 510 KV
 CIFO+ 960 KV
 CIFO- 1020 KV
 STRIKE DIST. 80 IN.
 LEAKAGE DIST. 140 IN.

MIN. MECHANICAL STRENGTH
 MDCL 1176 LBS.

MIN. ELEC./MECH. SPECIFICATIONS

MIN. ELECTRICAL VALUES
 60 HZ DRY FO 590 KV
 60 HZ WET FO 510 KV
 CIFO+ 960 KV
 CIFO- 1020 KV
 STRIKE DIST. 80 IN.
 LEAKAGE DIST. 140 IN.

MIN. MECHANICAL STRENGTH
 MDCL 1176 LBS.

MIN. ELEC./MECH. SPECIFICATIONS

MIN. ELECTRICAL VALUES
 60 HZ DRY FO 590 KV
 60 HZ WET FO 510 KV
 CIFO+ 960 KV
 CIFO- 1020 KV
 STRIKE DIST. 80 IN.
 LEAKAGE DIST. 140 IN.

MIN. MECHANICAL STRENGTH
 MDCL 1176 LBS.

MIN. ELEC./MECH. SPECIFICATIONS

MIN. ELECTRICAL VALUES
 60 HZ DRY FO 590 KV
 60 HZ WET FO 510 KV
 CIFO+ 960 KV
 CIFO- 1020 KV
 STRIKE DIST. 80 IN.
 LEAKAGE DIST. 140 IN.

MIN. MECHANICAL STRENGTH
 MDCL 1176 LBS.

MIN. ELEC./MECH. SPECIFICATIONS

MIN. ELECTRICAL VALUES
 60 HZ DRY FO 590 KV
 60 HZ WET FO 510 KV
 CIFO+ 960 KV
 CIFO- 1020 KV
 STRIKE DIST. 80 IN.
 LEAKAGE DIST. 140 IN.

MIN. MECHANICAL STRENGTH
 MDCL 1176 LBS.

MIN. ELEC./MECH. SPECIFICATIONS

MIN. ELECTRICAL VALUES
 60 HZ DRY FO 590 KV
 60 HZ WET FO 510 KV
 CIFO+ 960 KV
 CIFO- 1020 KV
 STRIKE DIST. 80 IN.
 LEAKAGE DIST. 140 IN.

MIN. MECHANICAL STRENGTH
 MDCL 1176 LBS.

MIN. ELEC./MECH. SPECIFICATIONS

MIN. ELECTRICAL VALUES
 60 HZ DRY FO 590 KV
 60 HZ WET FO 510 KV
 CIFO+ 960 KV
 CIFO- 1020 KV
 STRIKE DIST. 80 IN.
 LEAKAGE DIST. 140 IN.

MIN. MECHANICAL STRENGTH
 MDCL 1176 LBS.

MIN. ELEC./MECH. SPECIFICATIONS

MIN. ELECTRICAL VALUES
 60 HZ DRY FO 590 KV
 60 HZ WET FO 510 KV
 CIFO+ 960 KV
 CIFO- 1020 KV
 STRIKE DIST. 80 IN.
 LEAKAGE DIST. 140 IN.

MIN. MECHANICAL STRENGTH
 MDCL 1176 LBS.

MIN. ELEC./MECH. SPECIFICATIONS

MIN. ELECTRICAL VALUES
 60 HZ DRY FO 590 KV
 60 HZ WET FO 510 KV
 CIFO+ 960 KV
 CIFO- 1020 KV
 STRIKE DIST. 80 IN.
 LEAKAGE DIST. 140 IN.

MIN. MECHANICAL STRENGTH
 MDCL 1176 LBS.

MIN. ELEC./MECH. SPECIFICATIONS

MIN. ELECTRICAL VALUES
 60 HZ DRY FO 590 KV
 60 HZ WET FO 510 KV
 CIFO+ 960 KV
 CIFO- 1020 KV
 STRIKE DIST. 80 IN.
 LEAKAGE DIST. 140 IN.

MIN. MECHANICAL STRENGTH
 MDCL 1176 LBS.

MIN. ELEC./MECH. SPECIFICATIONS

MIN. ELECTRICAL VALUES
 60 HZ DRY FO 590 KV
 60 HZ WET FO 510 KV
 CIFO+ 960 KV
 CIFO- 1020 KV
 STRIKE DIST. 80 IN.
 LEAKAGE DIST. 140 IN.

MIN. MECHANICAL STRENGTH
 MDCL 1176 LBS.

MIN. ELEC./MECH. SPECIFICATIONS

MIN. ELECTRICAL VALUES
 60 HZ DRY FO 590 KV
 60 HZ WET FO 510 KV
 CIFO+ 960 KV
 CIFO- 1020 KV
 STRIKE DIST. 80 IN.
 LEAKAGE DIST. 140 IN.

MIN. MECHANICAL STRENGTH
 MDCL 1176 LBS.

MIN. ELEC./MECH. SPECIFICATIONS

MIN. ELECTRICAL VALUES
 60 HZ DRY FO 590 KV
 60 HZ WET FO 510 KV
 CIFO+ 960 KV
 CIFO- 1020 KV
 STRIKE DIST. 80 IN.
 LEAKAGE DIST. 140 IN.

MIN. MECHANICAL STRENGTH
 MDCL 1176 LBS.

MIN. ELEC./MECH. SPECIFICATIONS

MIN. ELECTRICAL VALUES
 60 HZ DRY FO 590 KV
 60 HZ WET FO 510 KV
 CIFO+ 960 KV
 CIFO- 1020 KV
 STRIKE DIST. 80 IN.
 LEAKAGE DIST. 140 IN.

MIN. MECHANICAL STRENGTH
 MDCL 1176 LBS.

MIN. ELEC./MECH. SPECIFICATIONS

MIN. ELECTRICAL VALUES
 60 HZ DRY FO 590 KV
 60 HZ WET FO 510 KV
 CIFO+ 960 KV
 CIFO- 1020 KV
 STRIKE DIST. 80 IN.
 LEAKAGE DIST. 140 IN.

MIN. MECHANICAL STRENGTH
 MDCL 1176 LBS.

MIN. ELEC./MECH. SPECIFICATIONS

MIN. ELECTRICAL VALUES
 60 HZ DRY FO 590 KV
 60 HZ WET FO 510 KV
 CIFO+ 960 KV
 CIFO- 1020 KV
 STRIKE DIST. 80 IN.
 LEAKAGE DIST. 140 IN.

MIN. MECHANICAL STRENGTH
 MDCL 1176 LBS.

MIN. ELEC./MECH. SPECIFICATIONS

MIN. ELECTRICAL VALUES
 60 HZ DRY FO 590 KV
 60 HZ WET FO 510 KV
 CIFO+ 960 KV
 CIFO- 1020 KV
 STRIKE DIST. 80 IN.
 LEAKAGE DIST. 140 IN.

MIN. MECHANICAL STRENGTH
 MDCL 1176 LBS.

MIN. ELEC./MECH. SPECIFICATIONS

MIN. ELECTRICAL VALUES
 60 HZ DRY FO 590 KV
 60 HZ WET FO 510 KV
 CIFO+ 960 KV
 CIFO- 1020 KV
 STRIKE DIST. 80 IN.
 LEAKAGE DIST. 140 IN.

MIN. MECHANICAL STRENGTH
 MDCL 1176 LBS.

MIN. ELEC./MECH. SPECIFICATIONS

MIN. ELECTRICAL VALUES
 60 HZ DRY FO 590 KV
 60 HZ WET FO 510 KV
 CIFO+ 960 KV
 CIFO- 1020 KV
 STRIKE DIST. 80 IN.
 LEAKAGE DIST. 140 IN.

MIN. MECHANICAL STRENGTH
 MDCL 1176 LBS.

MIN. ELEC./MECH. SPECIFICATIONS

MIN. ELECTRICAL VALUES
 60 HZ DRY FO 590 KV
 60 HZ WET FO 510 KV
 CIFO+ 960 KV
 CIFO- 1020 KV
 STRIKE DIST. 80 IN.
 LEAKAGE DIST. 140 IN.

MIN. MECHANICAL STRENGTH
 MDCL 1176 LBS.

MIN. ELEC./MECH. SPECIFICATIONS

MIN. ELECTRICAL VALUES
 60 HZ DRY FO 590 KV
 60 HZ WET FO 510 KV
 CIFO+ 960 KV
 CIFO- 1020 KV
 STRIKE DIST. 80 IN.
 LEAKAGE DIST. 140 IN.

MIN. MECHANICAL STRENGTH
 MDCL 1176 LBS.

MIN. ELEC./MECH. SPECIFICATIONS

MIN. ELECTRICAL VALUES
 60 HZ DRY FO 590 KV
 60 HZ WET FO 510 KV
 CIFO+ 960 KV
 CIFO- 1020 KV
 STRIKE DIST. 80 IN.
 LEAKAGE DIST. 140 IN.

MIN. MECHANICAL STRENGTH
 MDCL 1176 LBS.

MIN. ELEC./MECH. SPECIFICATIONS

MIN. ELECTRICAL VALUES
 60 HZ DRY FO 590 KV
 60 HZ WET FO 510 KV
 CIFO+ 960 KV
 CIFO- 1020 KV
 STRIKE DIST. 80 IN.
 LEAKAGE DIST. 140 IN.

MIN. MECHANICAL STRENGTH
 MDCL 1176 LBS.

MIN. ELEC./MECH. SPECIFICATIONS

MIN. ELECTRICAL VALUES
 60 HZ DRY FO 590 KV
 60 HZ WET FO 510 KV
 CIFO+ 960 KV
 CIFO- 1020 KV
 STRIKE DIST. 80 IN.
 LEAKAGE DIST. 140 IN.

MIN. MECHANICAL STRENGTH
 MDCL 1176 LBS.

MIN. ELEC./MECH. SPECIFICATIONS

MIN. ELECTRICAL VALUES
 60 HZ DRY FO 590 KV
 60 HZ WET FO 510 KV
 CIFO+ 960 KV
 CIFO- 1020 KV
 STRIKE DIST. 80 IN.
 LEAKAGE DIST. 140 IN.

MIN. MECHANICAL STRENGTH
 MDCL 1176 LBS.

MIN. ELEC./MECH. SPECIFICATIONS

MIN. ELECTRICAL VALUES
 60 HZ DRY FO 590 KV
 60 HZ WET FO 510 KV
 CIFO+ 960 KV
 CIFO- 1020 KV
 STRIKE DIST. 80 IN.
 LEAKAGE DIST. 140 IN.

MIN. MECHANICAL STRENGTH
 MDCL 1176 LBS.

MIN. ELEC./MECH. SPECIFICATIONS

MIN. ELECTRICAL VALUES
 60 HZ DRY FO 590 KV
 60 HZ WET FO 510 KV
 CIFO+ 960 KV
 CIFO- 1020 KV
 STRIKE DIST. 80 IN.
 LEAKAGE DIST. 140 IN.

MIN. MECHANICAL STRENGTH
 MDCL 1176 LBS.

MIN. ELEC./MECH. SPECIFICATIONS

MIN. ELECTRICAL VALUES
 60 HZ DRY FO 590 KV
 60 HZ WET FO 510 KV
 CIFO+ 960 KV
 CIFO- 1020 KV
 STRIKE DIST. 80 IN.
 LEAKAGE DIST. 140 IN.

MIN. MECHANICAL STRENGTH
 MDCL 1176 LBS.

MIN. ELEC./MECH. SPECIFICATIONS

MIN. ELECTRICAL VALUES
 60 HZ DRY FO 590 KV
 60 HZ WET FO 510 KV
 CIFO+ 960 KV
 CIFO- 1020 KV
 STRIKE DIST. 80 IN.
 LEAKAGE DIST. 140 IN.

MIN. MECHANICAL STRENGTH
 MDCL 1176 LBS.

MIN. ELEC./MECH. SPECIFICATIONS

MIN. ELECTRICAL VALUES
 60 HZ DRY FO 590 KV
 60 HZ WET FO 510 KV
 CIFO+ 960 KV
 CIFO- 1020 KV
 STRIKE DIST. 80 IN.
 LEAKAGE DIST. 140 IN.

MIN. MECHANICAL STRENGTH
 MDCL 1176 LBS.

MIN. ELEC./MECH. SPECIFICATIONS

MIN. ELECTRICAL VALUES
 60 HZ DRY FO 590 KV
 60 HZ WET FO 510 KV
 CIFO+ 960 KV
 CIFO- 1020 KV
 STRIKE DIST. 80 IN.
 LEAKAGE DIST. 140 IN.

MIN. MECHANICAL STRENGTH
 MDCL 1176 LBS.

MIN. ELEC./MECH. SPECIFICATIONS

MIN. ELECTRICAL VALUES
 60 HZ DRY FO 590 KV
 60 HZ WET FO 510 KV
 CIFO+ 960 KV
 CIFO- 1020 KV
 STRIKE DIST. 80 IN.
 LEAKAGE DIST. 140 IN.

MIN. MECHANICAL STRENGTH
 MDCL 1176 LBS.

MIN. ELEC./MECH. SPECIFICATIONS

MIN. ELECTRICAL VALUES
 60 HZ DRY FO 590 KV
 60 HZ WET FO 510 KV
 CIFO+ 960 KV
 CIFO- 1020 KV
 STRIKE DIST. 80 IN.
 LEAKAGE DIST. 140 IN.

MIN. MECHANICAL STRENGTH
 MDCL 1176 LBS.

MIN. ELEC./MECH. SPECIFICATIONS

MIN. ELECTRICAL VALUES
 60 HZ DRY FO 590 KV
 60 HZ WET FO 510 KV
 CIFO+ 960 KV
 CIFO- 1020 KV
 STRIKE DIST. 80 IN.
 LEAKAGE DIST. 140 IN.

MIN. MECHANICAL STRENGTH
 MDCL 1176 LBS.

MIN. ELEC./MECH. SPECIFICATIONS

MIN. ELECTRICAL VALUES
 60 HZ DRY FO 590 KV
 60 HZ WET FO 510 KV
 CIFO+ 960 KV
 CIFO- 1020 KV
 STRIKE DIST. 80 IN.
 LEAKAGE DIST. 140 IN.

MIN. MECHANICAL STRENGTH
 MDCL 1176 LBS.

MIN. ELEC./MECH. SPECIFICATIONS

MIN. ELECTRICAL VALUES
 60 HZ DRY FO 5

Appendix 2: High Voltage Overhead Transmission

Attachment 1: APPLICABLE STANDARD FRAMING AND ASSEMBLY DRAWINGS

DEN	SPECIAL FRAMING CHARACTERISTICS		SP. DESIGNATION
	FRAMING TYPE	SP. NUMBER (CONSTRUCTION PROJECT)	
1-1	1-1	1-1	1-1
1-2	1-2	1-2	1-2
1-3	1-3	1-3	1-3
1-4	1-4	1-4	1-4
1-5	1-5	1-5	1-5
1-6	1-6	1-6	1-6
1-7	1-7	1-7	1-7
1-8	1-8	1-8	1-8
1-9	1-9	1-9	1-9
1-10	1-10	1-10	1-10
1-11	1-11	1-11	1-11
1-12	1-12	1-12	1-12
1-13	1-13	1-13	1-13
1-14	1-14	1-14	1-14
1-15	1-15	1-15	1-15
1-16	1-16	1-16	1-16
1-17	1-17	1-17	1-17
1-18	1-18	1-18	1-18
1-19	1-19	1-19	1-19
1-20	1-20	1-20	1-20
1-21	1-21	1-21	1-21
1-22	1-22	1-22	1-22
1-23	1-23	1-23	1-23
1-24	1-24	1-24	1-24
1-25	1-25	1-25	1-25
1-26	1-26	1-26	1-26
1-27	1-27	1-27	1-27
1-28	1-28	1-28	1-28
1-29	1-29	1-29	1-29
1-30	1-30	1-30	1-30
1-31	1-31	1-31	1-31
1-32	1-32	1-32	1-32
1-33	1-33	1-33	1-33
1-34	1-34	1-34	1-34
1-35	1-35	1-35	1-35
1-36	1-36	1-36	1-36
1-37	1-37	1-37	1-37
1-38	1-38	1-38	1-38
1-39	1-39	1-39	1-39
1-40	1-40	1-40	1-40
1-41	1-41	1-41	1-41
1-42	1-42	1-42	1-42
1-43	1-43	1-43	1-43
1-44	1-44	1-44	1-44
1-45	1-45	1-45	1-45
1-46	1-46	1-46	1-46
1-47	1-47	1-47	1-47
1-48	1-48	1-48	1-48
1-49	1-49	1-49	1-49
1-50	1-50	1-50	1-50

* FOR SPECIAL CONSTRUCTION PROJECTS

NEW
SUSPENSION

GENERAL NOTE - THIS LINE SHALL BE INSTALLED IN ACCORDANCE WITH THE REQUIREMENTS OF THE DESIGN DRAWING. ALL INSULATORS SHALL BE INSTALLED IN ACCORDANCE WITH THE REQUIREMENTS OF THE DESIGN DRAWING. ALL SHOWN INSULATORS SHALL HAVE CORONA RINGS ON LINE ENDS.

ALL SHOWN SUSPENSION INSULATORS SHALL HAVE CORONA RINGS ON LINE ENDS.

NEW
LINE POST

GENERAL NOTE - THIS LINE SHALL BE INSTALLED IN ACCORDANCE WITH THE REQUIREMENTS OF THE DESIGN DRAWING. ALL INSULATORS SHALL BE INSTALLED IN ACCORDANCE WITH THE REQUIREMENTS OF THE DESIGN DRAWING. ALL SHOWN INSULATORS SHALL HAVE CORONA RINGS ON LINE ENDS.

ALL SHOWN LINE POSTS SHALL HAVE CORONA RINGS ON LINE ENDS.

Appendix 2: High Voltage Overhead Transmission

Attachment 1: APPLICABLE STANDARD FRAMING AND ASSEMBLY DRAWINGS

BILL OF MATERIALS

DEADEND, POLYMER, WITH BUNDLING YOKE, 500KV

ITEM	COMP. QTY.	BOLTED QTY.	STOCK NO.	DESCRIPTION
1	2	2	0032009672	SHACKLE, CHAIN, 150k ULT .STR.
2	1	1	0032009669	YOKE PLATE, TRIPLE BUNDLE, DEADEND, 18" SEPARATION, 110k ULT. STR.
3	14	11	0000000689	SHACKLE, ANCHOR, 60k ULT. STR.
4	1	1	0032009670	YOKE PLATE, TRIPLE BUNDLED, DEADEND, 18" SEPARATION, 110k ULT. STR.
5	1	1	0032009665	LINK EXTENSION, EYE-EYE, 40k ULT. STR.
6	3	3	0032009668	PLATE, ADJUSTMENT, 40k ULT. STR.
7	3	3	0032000342	INSULATOR, LINE, EYE-BALL, POLYMER, 500kV, 50k ULT .STR.
8	3		LS9012XX	DEADEND, COMPRESSION, ALUMINUM, SINGLE TONGUE, 33k, FOR VARIABLE
9	3	3	0000028529	SOCKET, Y-CLEVIS, 50k
10	1	1	0032000136	LINK, CHAIN, 132k ULT., 7" LONG
11		3	0032021867	CLEVIS BALL, 35k, BALL CLASS 52-3/5
12		3	LS9013XX	DEADEND, BOLTED, STRAIN, ALUM., 30k, FOR VARIABLE WIRE SIZE
13	1	1	0032009685	CORONA RING, 500kV DEADEND, ALUM.
14	3		LS9014XX	TERMINAL CONNECTOR, 15 DEG., FOR VARIABLE WIRE SIZE
15*		3	LS5029XX	JUMPER, SPLICE, FOR VARIABLE WIRE SIZE

CONDUCTOR	CONDUCTOR DIA.	COMP. D.E. (ITEMS 8 & 14)	ENTERGY STOCK NO.	ASSEMBLY CAT. NO.	ENTERGY STOCK NO.
1024 ACAR	1.165	VES-130-EHV**	0032000078	C-7686-DE1	NA
954.0 45/7 "RAIL"	1.165	VES-133-EHV**	0032021873	C-7686-DE2	NA
954 54/7 "CARDINAL"	1.196	VES-135-EHV**	0032021874	C-7686-DE4	NA

CONDUCTOR RANGE:	BOLTED STRAIN CLAMP (ITEM 12)	ENTERGY STOCK NO.	ASSEMBLY CAT. NO.	ENTERGY STOCK NO.
.710" - 1.318"	ADE-2526-S-SPH4	0000028892	C-7686-DE3	NA

* ITEMS 15 ARE NOT FURNISHED WITH THE MACLEAN ASSEMBLIES.
 ** COMPRESSION DEADEND BODIES COME WITH JUMPER TERMINALS, ITEM 14. EITHER OF OF ITEMS 8 AND 14 CAN BE RETURNED TO STORES WITH THEIR SEPARATE STOCK CODES.

1) ITEM #8, #12, #14 & #15 ARE CONDUCTOR DEPENDENT.
 2) DESIGNER MAY SUBSTITUTE #11 & #12 & #15, FOR ITEMS #3 (QTY. 2) & #8. STRAIN CLAMP SHALL INCLUDE SOCKET EYE FOR A 52-3/5 BALL. USE OF BOLTED CLAMPS WILL REQUIRE THE USE OF NON-TENSION JUMPER SPLICES.

RE: MACLEAN DWG. BC-7686-1

ENTERGY SERVICES, INC.	
DEADEND, POLYMER, W/BUNDLING YOKE, 500kV	
STD NO.	SCALE: NONE
No. TFA200A0	
PLOT 1=1 SH. 1 OF 1	

0	03-05-07	CREATED	TWF	HSK
ND.	DATE:	REVISION	BY:	CHK/ APPR
	tfnrc90	3/5/2007		

DEPY-500-XX; BC-7686-1

Appendix 2: High Voltage Overhead Transmission

Attachment 1: APPLICABLE STANDARD FRAMING AND ASSEMBLY DRAWINGS

BILL OF MATERIALS			
JUMPER LINE POST, POLYMER, w/BUNDLING YOKE, HORIZONTAL, 500kV			
ITEM	QTY.	STOCK NO.	DESCRIPTION
1	1	LS9015XX	JUMPER YOKE, 10k ULT. STR. 18" SEPARATION, ALUMINUM ALLOY
2	1	0032021878	INSULATOR, LINE POST, 3", POLYMER, 500kV, 10k ULT. STR.

CONDUCTOR	CONDUCTOR DIA.	JMPR. YOKE (ITEM 1)	ENTERGY STOCK NO.	ASSEMBLY CAT. NO.	ENTERGY STOCK NO.
1024 ACAR	1.165	C-7686-4	0032021850	C-7686-J2	NA
954.0 45/7 "RAIL"	1.165	C-7686-4	0032021850	C-7686-J2	NA
954 54/7 "CARDINAL"	1.196	C-7686-4A	0032021860	C-7686-J2A	NA

1) ITEM #1 IS CONDUCTOR DEPENDENT. THIS ITEM IS SELECTED FOR EACH PROJECT (WITHOUT ARMOR RODS).

RE: MACLEAN DWG. BC-7686-4

ENTERGY SERVICES, INC.	
JUMPER LINE POST, POLYMER, W/YOKE, HOR, 500KV	
STD NO.	SCALE: NONE
No. TFA201A0	
Entergy	
PLOT 1=1	SH. 1 OF 1
JLPB-HJ-500-XX; BC-7686-4	

0	03-05-07	CREATED	TWF	HSK	
NO.	DATE	REVISION	BY	CHK	APPR
		3/19/2007			

tfinc90

Appendix 2: High Voltage Overhead Transmission

Attachment 1: APPLICABLE STANDARD FRAMING AND ASSEMBLY DRAWINGS

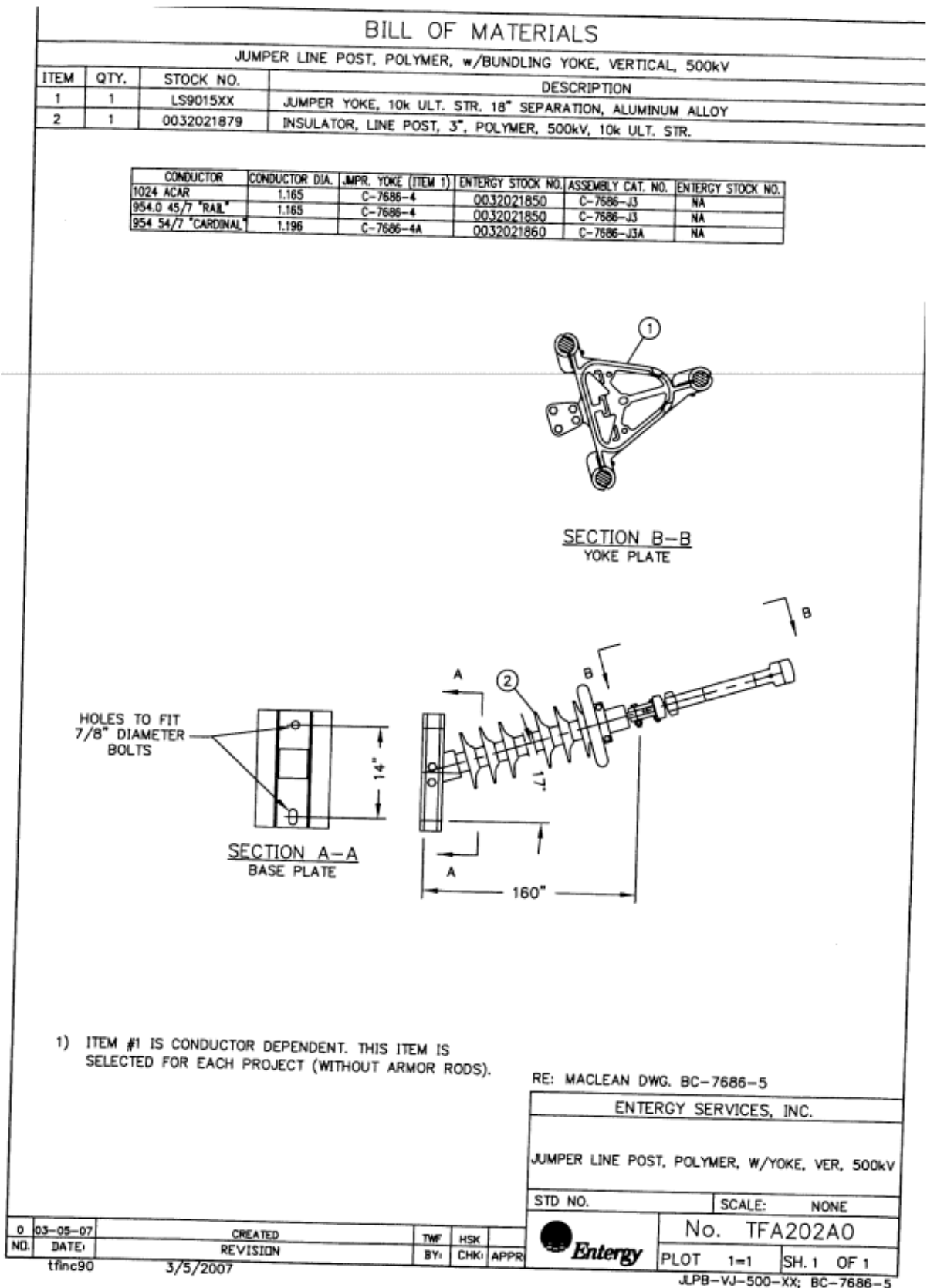

Appendix 2: High Voltage Overhead Transmission

Attachment 1: APPLICABLE STANDARD FRAMING AND ASSEMBLY DRAWINGS

BILL OF MATERIALS			
JUMPER SUSPENSION, POLYMER, w/ BUNDLING YOKE 500kV			
ITEM	QTY.	STOCK NO.	DESCRIPTION
1	1	0000004466	SHACKLE, ANCHOR, 30k ULT. STR., 5/8" PIN DIA. 2-13/16"
2	1	0000028889	BALL EYE, OVAL, 35k ULT. STR., BALL CLASS 52-3/5
3	1	LS9016XX	YOKE, JUMPER, 10k ULT. STR. 18" SEPARATION, ALUM. ALLOY
4	1	0032000277	INSULATOR, SUSPENSION, B&S, POLYMER, 500kV, 25k ULT. STR.
5	1	0032021870	CLEVIS, SOCKET, 30k ULT. STR., CLASS 52-3/5

CONDUCTOR	CONDUCTOR DIA.	JMPR. YOKE (ITEM 3)	ENTERGY STOCK NO.	ASSEMBLY CAT. NO.	ENTERGY STOCK NO.
1024 ACAR	1.165	C-6549-3	0032021827	C-7686-J1	NA
954.0 45/7 "RAIL"	1.165	C-6549-3	0032021827	C-7686-J1	NA
954 54/7 "CARDINAL"	1.196	C-7686-5	0032021863	C-7686-J1A	NA

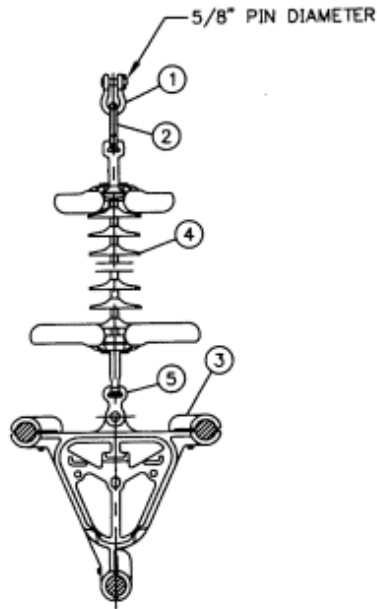

1) ITEM #3 IS CONDUCTOR DEPENDENT.
THIS ITEM IS SELECTED FOR EACH
PROJECT WITHOUT ARMOR RODS.

RE: MACLEAN DWG. BC-7686-2

ENTERGY SERVICES, INC.	
JUMPER SUSPENSION, POLYMER, W/YOKE, 500kV	
STD NO.	SCALE: NONE

-05-07	CREATED	TWF	HSK		
DATE:	REVISION	BY:	CHK:	APP:	
tfinc90	3 5 2007				

Entergy	No. TFA203A0	
	PLOT 1=1	SH.1 OF 1
JSPB-500-XX; BC-7686-2		

Appendix 2: High Voltage Overhead Transmission

Attachment 1: APPLICABLE STANDARD FRAMING AND ASSEMBLY DRAWINGS

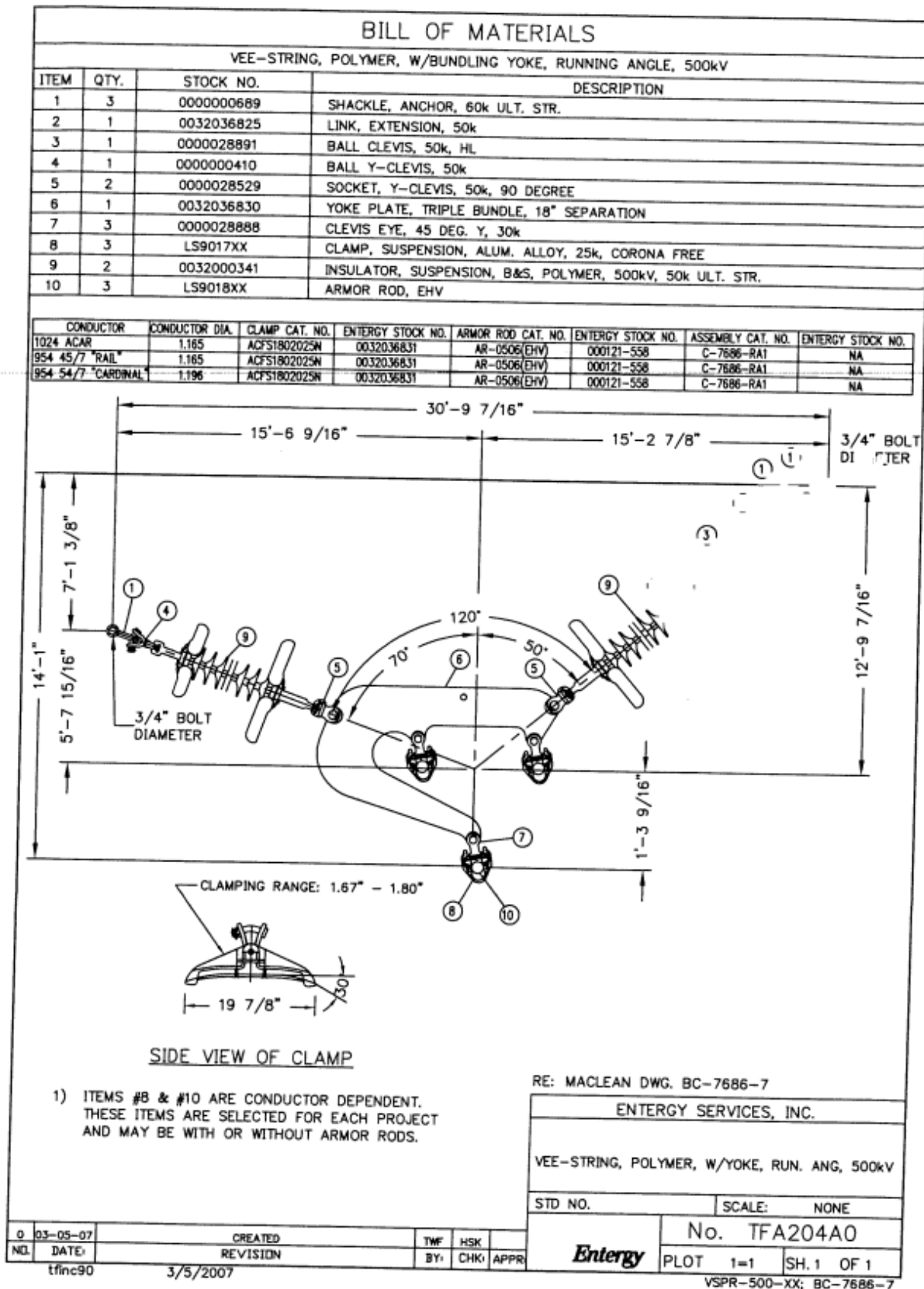

Appendix 2: High Voltage Overhead Transmission

Attachment 1: APPLICABLE STANDARD FRAMING AND ASSEMBLY DRAWINGS

BILL OF MATERIALS							
VEE-STRING, POLYMER, W/BUNDLING YOKE, 500kV							
ITEM	QTY.	STOCK NO.	DESCRIPTION				
1	4	0000000689	SHACKLE, ANCHOR, 60k ULT. STR.				
2	2	0032034296	LINK, EXTENSION, 50k				
3	2	0000028891	BALL CLEVIS, 50k				
4	2	0000028529	SOCKET, Y-CLEVIS, 50k				
5	1	0032021845	YOKE PLATE, TRIPLE BUNDLE, 18" SEPARATION				
6	3	0000028888	CLEVIS EYE, 45 DEG. Y, 30k				
7	3	LS9019XX	CLAMP, SUSPENSION, ALUM. ALLOY, 25k, CORONA FREE				
8	2	0032000341	INSULATOR, SUSPENSION, B&S, POLYMER, 500kV, 50k ULT. STR.				
9	3	LS9018XX	ARMOR ROD, EHV				

CONDUCTOR	CONDUCTOR DIA.	CLAMP CAT. NO.	ENERGY STOCK NO.	ARMOR ROD CAT. NO.	ENERGY STOCK NO.	ASSEMBLY CAT. NO.	ENERGY STOCK NO.
1024 ACAR	1.165	CF-184-N	0000028890	AR-0506(EHV)	000121-558	C-8098-VS1	NA
954 45/7 "RAIL"	1.165	CF-184-N	0000028890	AR-0506(EHV)	000121-558	C-8098-VS1	NA
954 54/7 "CARDINAL"	1.196	CF-184-N	0000028890	AR-0506(EHV)	000121-558	C-8098-VS1	NA

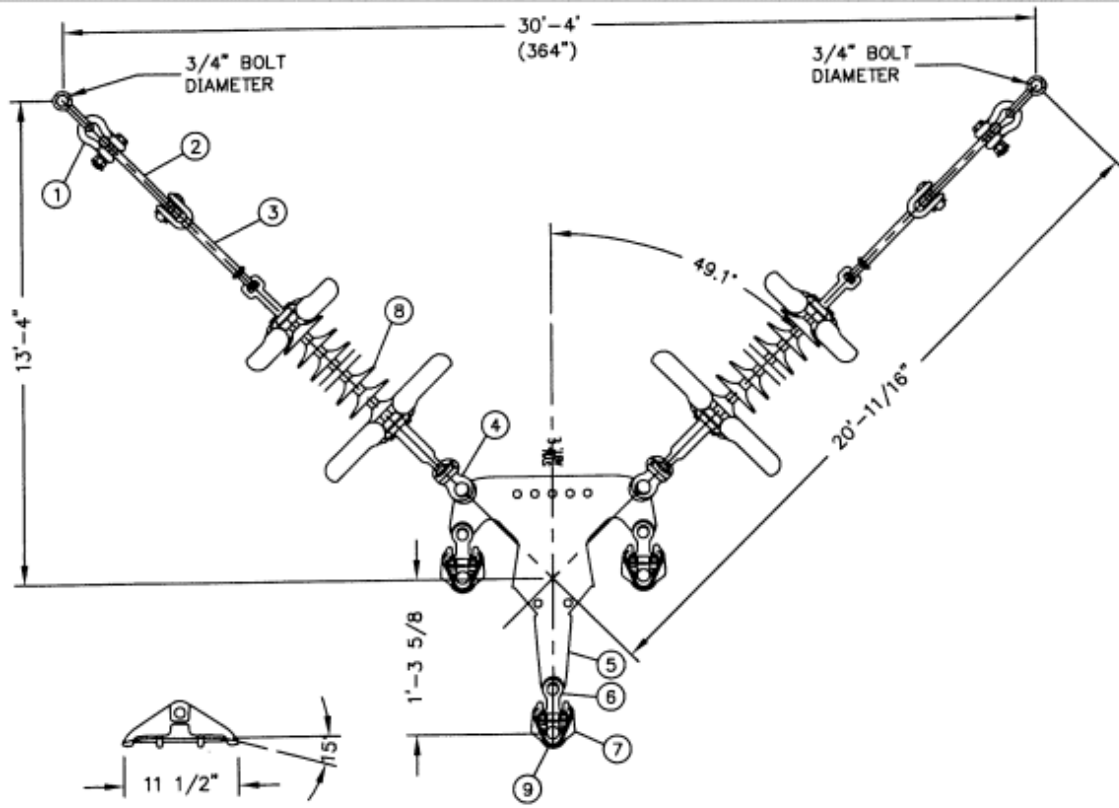

SIDE VIEW OF CLAMP

- 1) ITEMS #7 & #9 ARE CONDUCTOR DEPENDENT. THESE ITEMS ARE SELECTED FOR EACH PROJECT AND MAY BE WITH OR WITHOUT ARMOR RODS.

RE: MACLEAN DWG. BC-8098-1

ENERGY SERVICES, INC.	
VEE-STRING, POLYMER, W/BUNDLING YOKE, 500kV	
STD NO.	SCALE: NONE
No. TFA205A0	
Plot	1=1 SH.1 OF 1

NO.	DATE	CREATED	TWF	HSK	BY	CHK	APPR
0	03-05-07						
		REVISION					

tfinc90

3/5/2007



VSPY-500-XX; BC-8098-1

Appendix 2: High Voltage Overhead Transmission

Attachment 1: APPLICABLE STANDARD FRAMING AND ASSEMBLY DRAWINGS

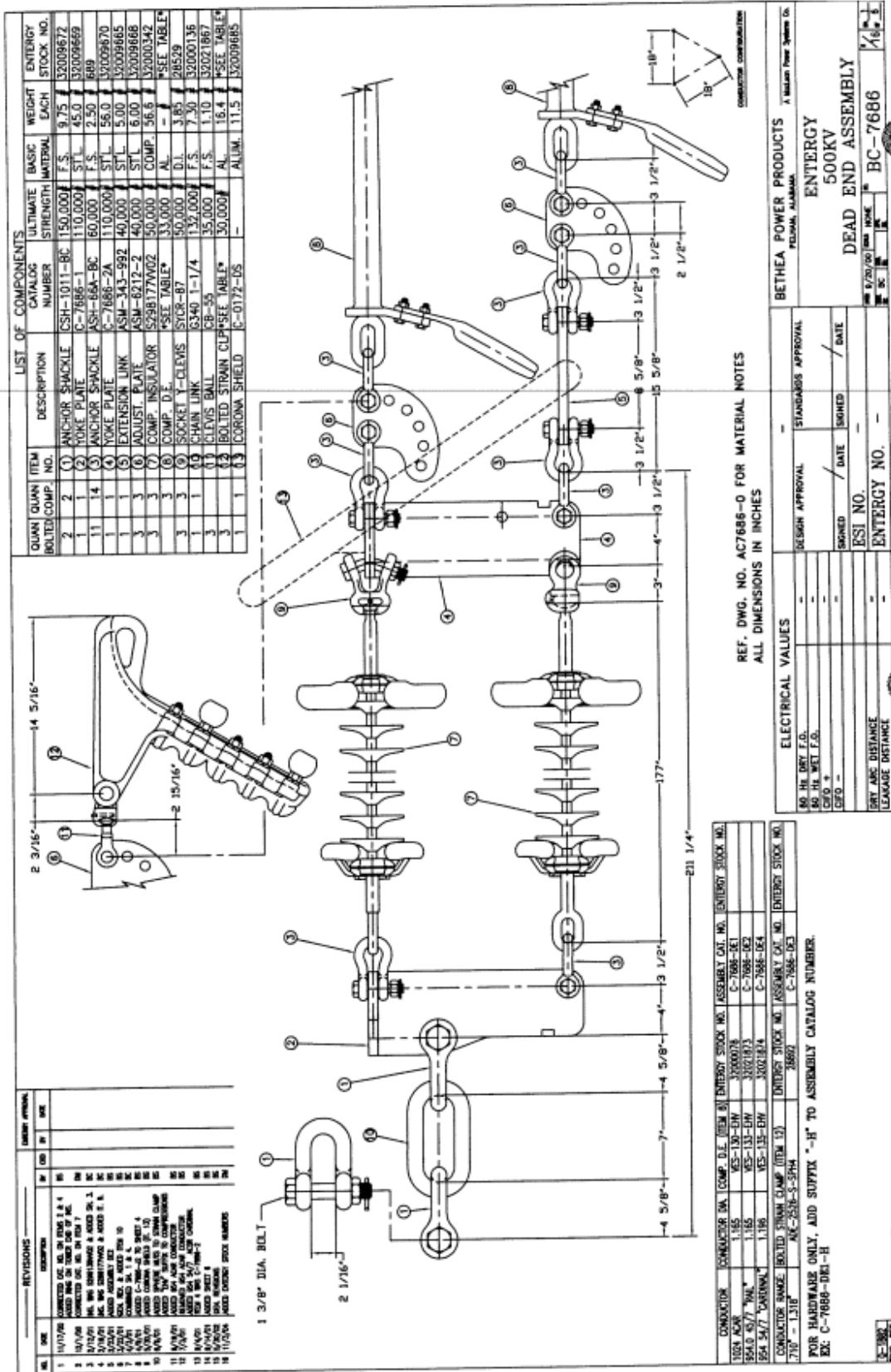

Appendix 2: High Voltage Overhead Transmission

Attachment 1: APPLICABLE STANDARD FRAMING AND ASSEMBLY DRAWINGS

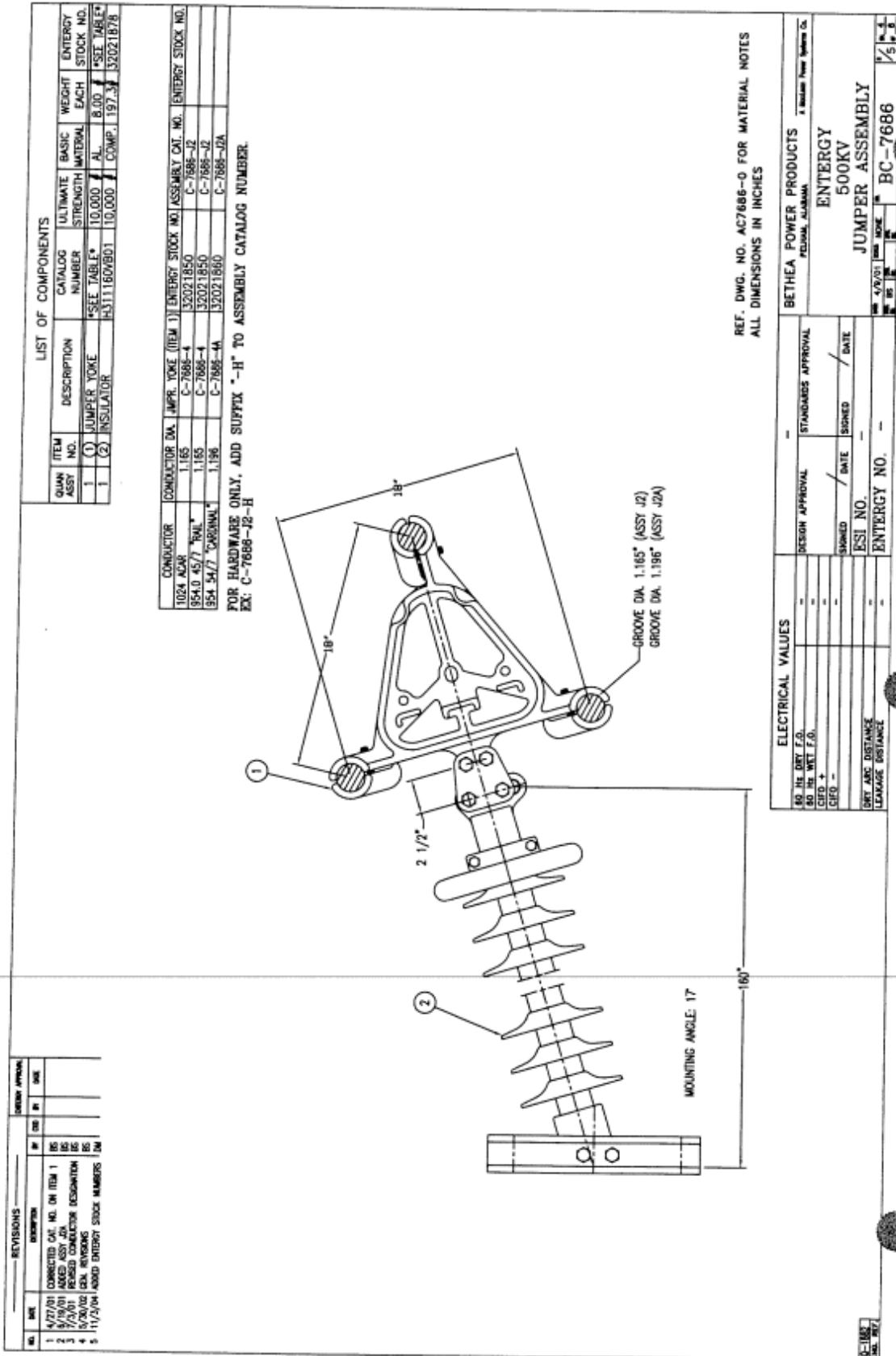

Appendix 2: High Voltage Overhead Transmission

Attachment 1: APPLICABLE STANDARD FRAMING AND ASSEMBLY DRAWINGS

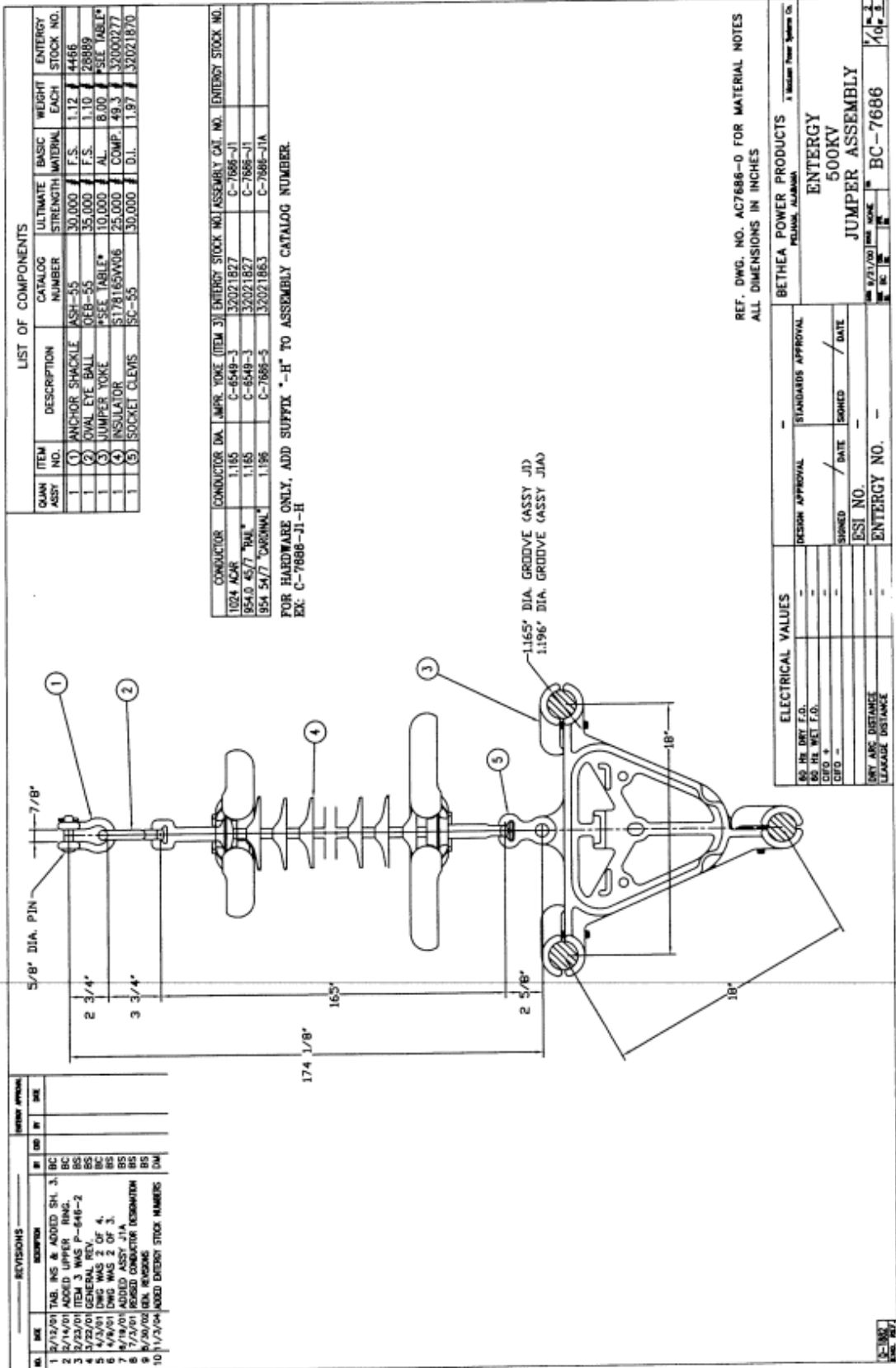

Appendix 2: High Voltage Overhead Transmission

Attachment 1: APPLICABLE STANDARD FRAMING AND ASSEMBLY DRAWINGS

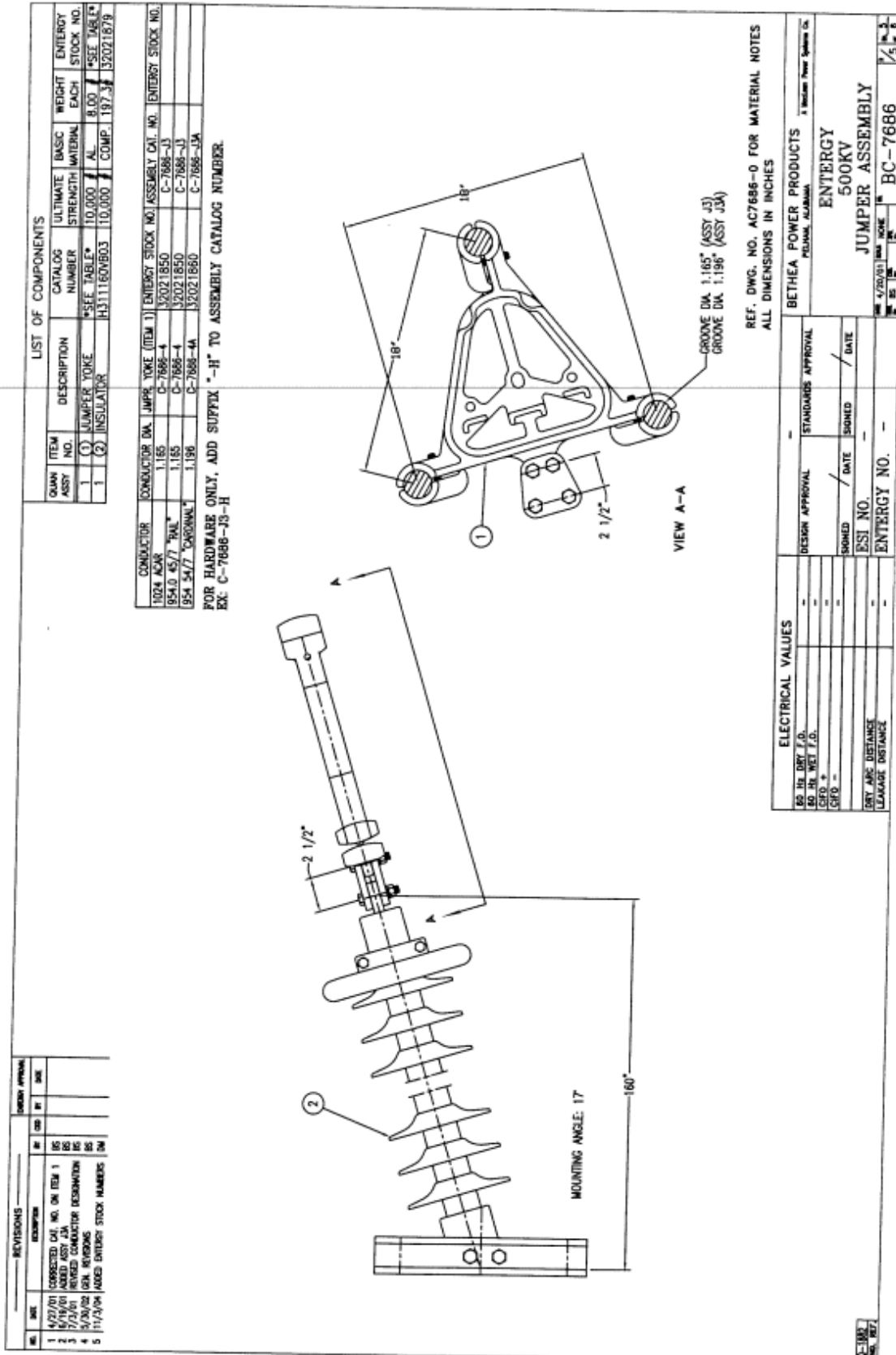

Appendix 2: High Voltage Overhead Transmission

Attachment 1: APPLICABLE STANDARD FRAMING AND ASSEMBLY DRAWINGS

REVISIONS

NO.	DATE	DESCRIPTION	BY	CHK	INT.
1	2/14/01	GEN. CAT. NO. WAS 5278159A03	BC	BC	
2	2/23/01	GEN. REV.	BC	BC	
3	3/22/01	GEN. REV.	BC	BC	
4	4/3/01	DWG WAS 3 OF 4	BC	BC	
5	4/9/01	DWG WAS 3 OF 4	BC	BC	
6	6/18/01	ADDED 90° V-ANGLE	BC	BC	
7	7/3/01	ADDED 90° V-ANGLE	BC	BC	
8	5/26/02	REVISED CONDUCTOR DESIGNATION	BC	BC	
9	11/3/04	ADDED ENERGY STOCK NUMBERS	BC	BC	

LIST OF COMPONENTS

QUAN.	ITEM NO.	DESCRIPTION	CATALOG NUMBER	ULTIMATE STRENGTH	BASIC MATERIAL	WEIGHT EACH	ENERGY STOCK NO.
1	(1)	ANCHOR SHACKLE	ASH-66A-BC	60,000	F.S.	2.25	589
2	(2)	EXTENSION LINK	EL50-76-XX	50,000	STL	0.00	NONE
2	(3)	CLEVIS BALL HL.	CBHL-76	50,000	F.S.	3.75	28891
2	(4)	90° SOC. Y-CLEVIS	SYCR-87	50,000	D.L.	3.65	28579
1	(5)	TOKE PLATE	C-7407-1	50,000	STL	38.8	32009671
3	(6)	90° Y-CLEVIS EYE	RYC-65-2187	30,000	D.L.	3.05	28888
3	(7)	CORONA FREE CLAMP	CF-184-N	25,000	AL	5.10	28890
2	(8)	INSULATOR	SZ78159A03	50,000	COMP	59.2	37000341
3	(9)	ANCHOR ROD	ARC-2950	ALUM		11.5	383

CONDUCTOR	CONDUCTOR DIA.	ASSEMBLY CAT. NO.	ENERGY STOCK NO.
1024 ACAR	1.165	C-7686-VS1	
954.0 45/7 "SAL"	1.165	C-7686-VS1	
954.547 "CARONNA"	1.196	C-7686-VS1	

FOR HARDWARE ONLY, ADD SUFFIX "-H" TO ASSEMBLY CATALOG NUMBER.
EX: C-7686-VS1-H

DESIGN APPROVAL	STANDARDS APPROVAL	ENERGY
SIGNED / DATE	SIGNED / DATE	SIGNED / DATE
EST. NO.	EST. NO.	EST. NO.
ENERGY NO.	ENERGY NO.	ENERGY NO.

ELECTRICAL VALUES	
DRY AIR DISTANCE	
WET DISTANCE	
LEAKAGE DISTANCE	

BETHEA POWER PRODUCTS
MOBILE, ALABAMA

REF. DWG. NO. AC7686-0 FOR MATERIAL NOTES
ALL DIMENSIONS IN INCHES

Not used.

Appendix 2: High Voltage Overhead Transmission

Attachment 1: APPLICABLE STANDARD FRAMING AND ASSEMBLY DRAWINGS

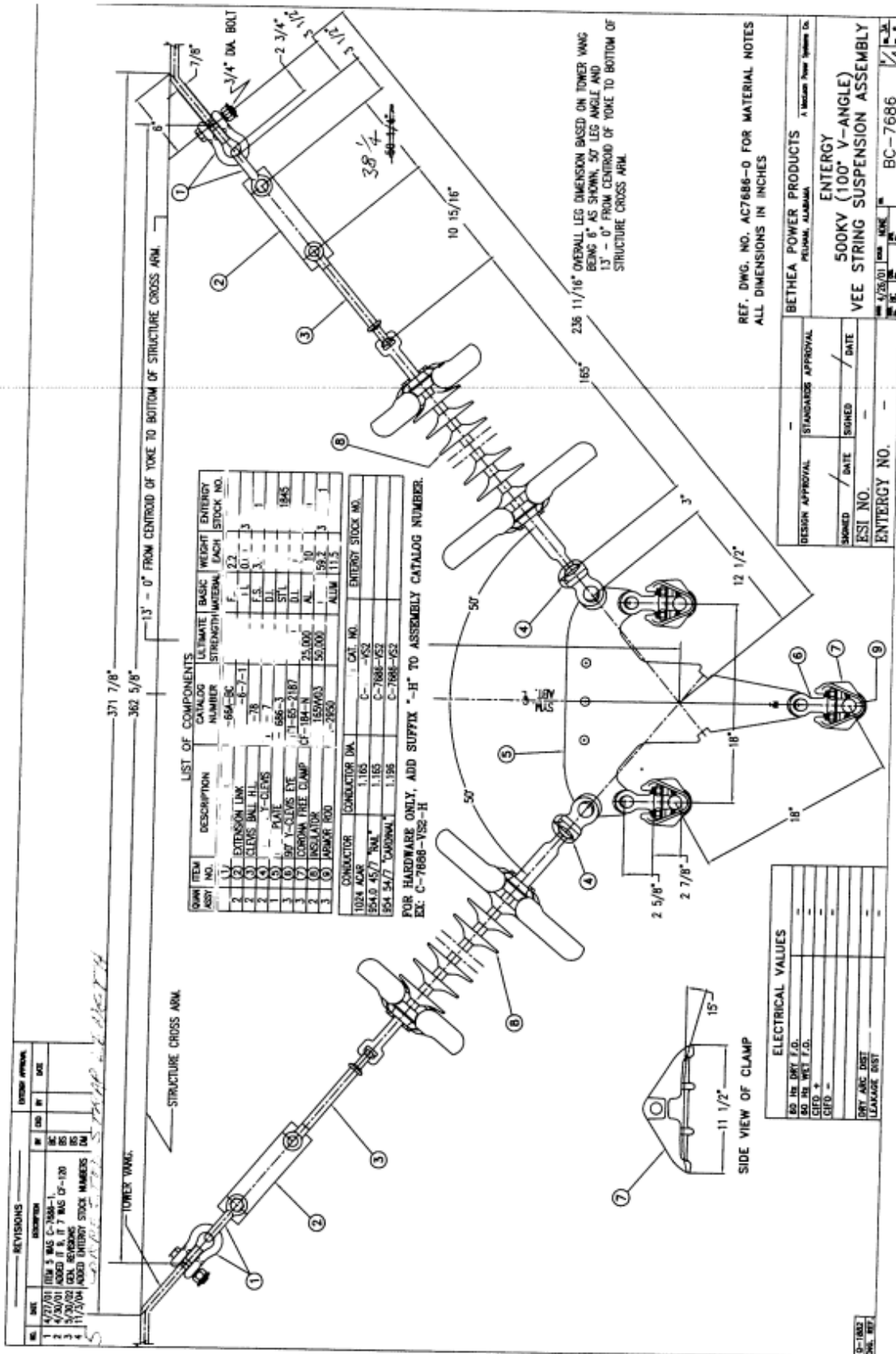

Appendix 2: High Voltage Overhead Transmission

Attachment 1: APPLICABLE STANDARD FRAMING AND ASSEMBLY DRAWINGS

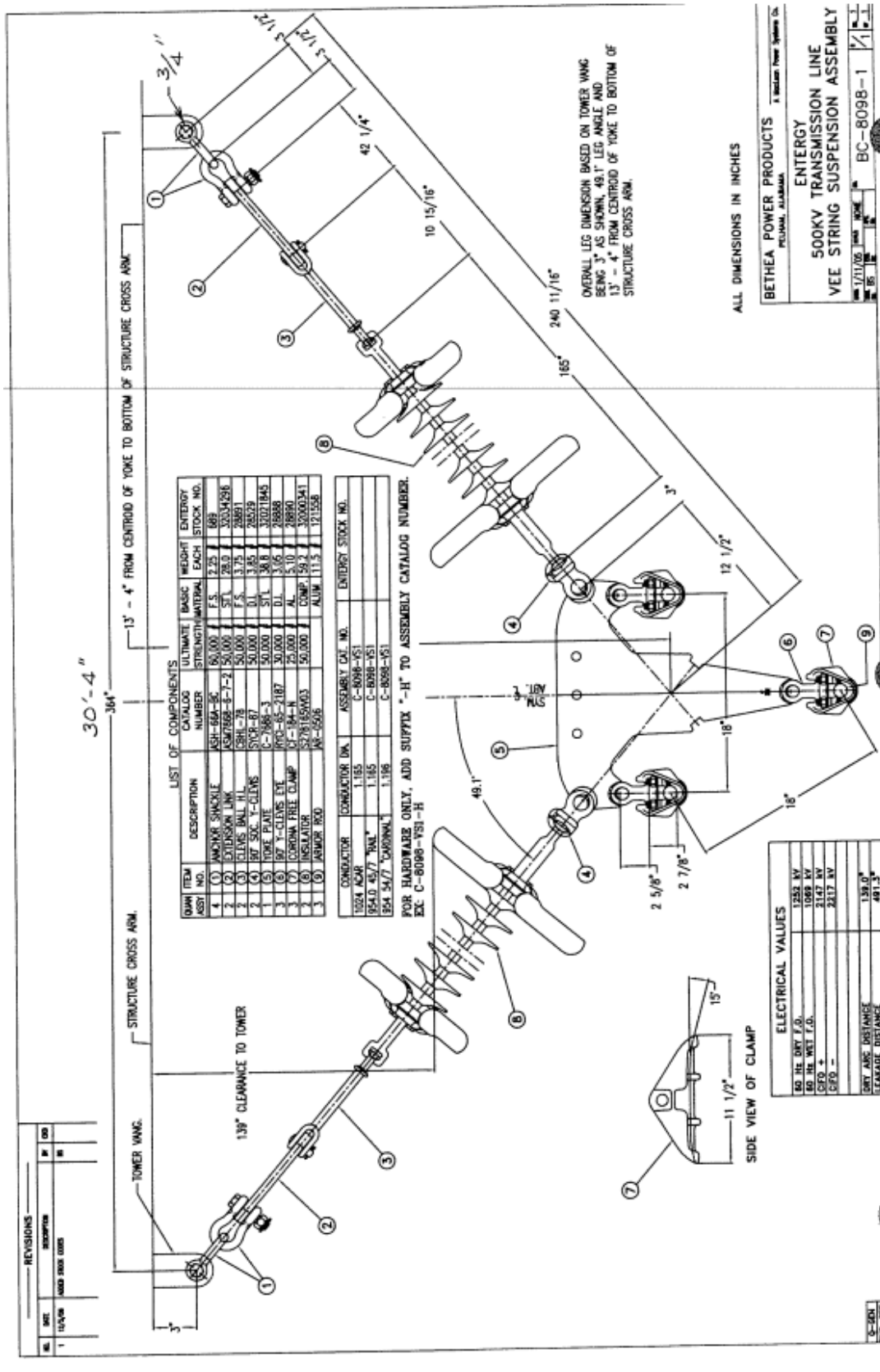

Appendix 2: High Voltage Overhead Transmission

Attachment 1: APPLICABLE STANDARD FRAMING AND ASSEMBLY DRAWINGS

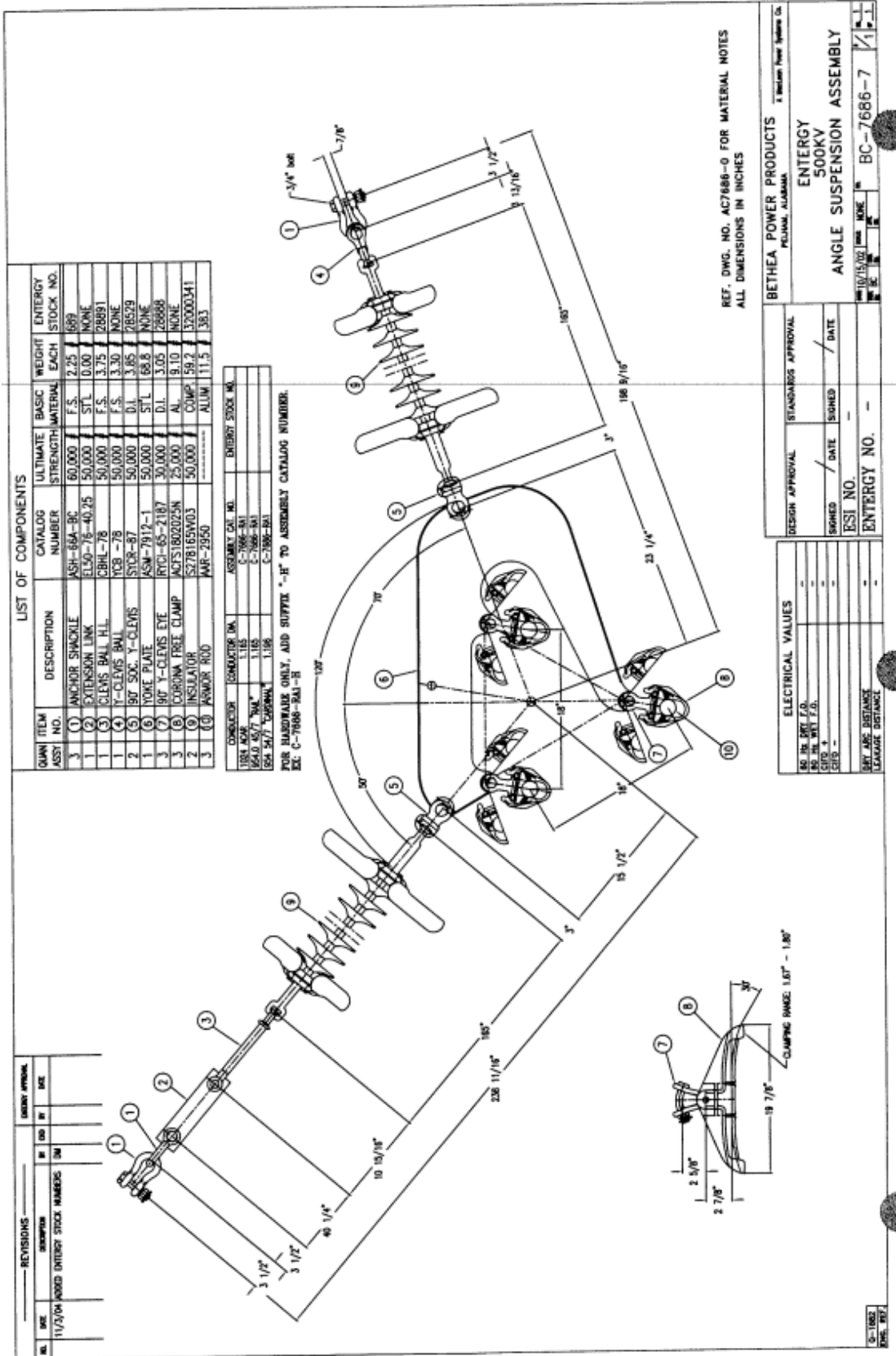

Appendix 2: High Voltage Overhead Transmission

Attachment 1: APPLICABLE STANDARD FRAMING AND ASSEMBLY DRAWINGS

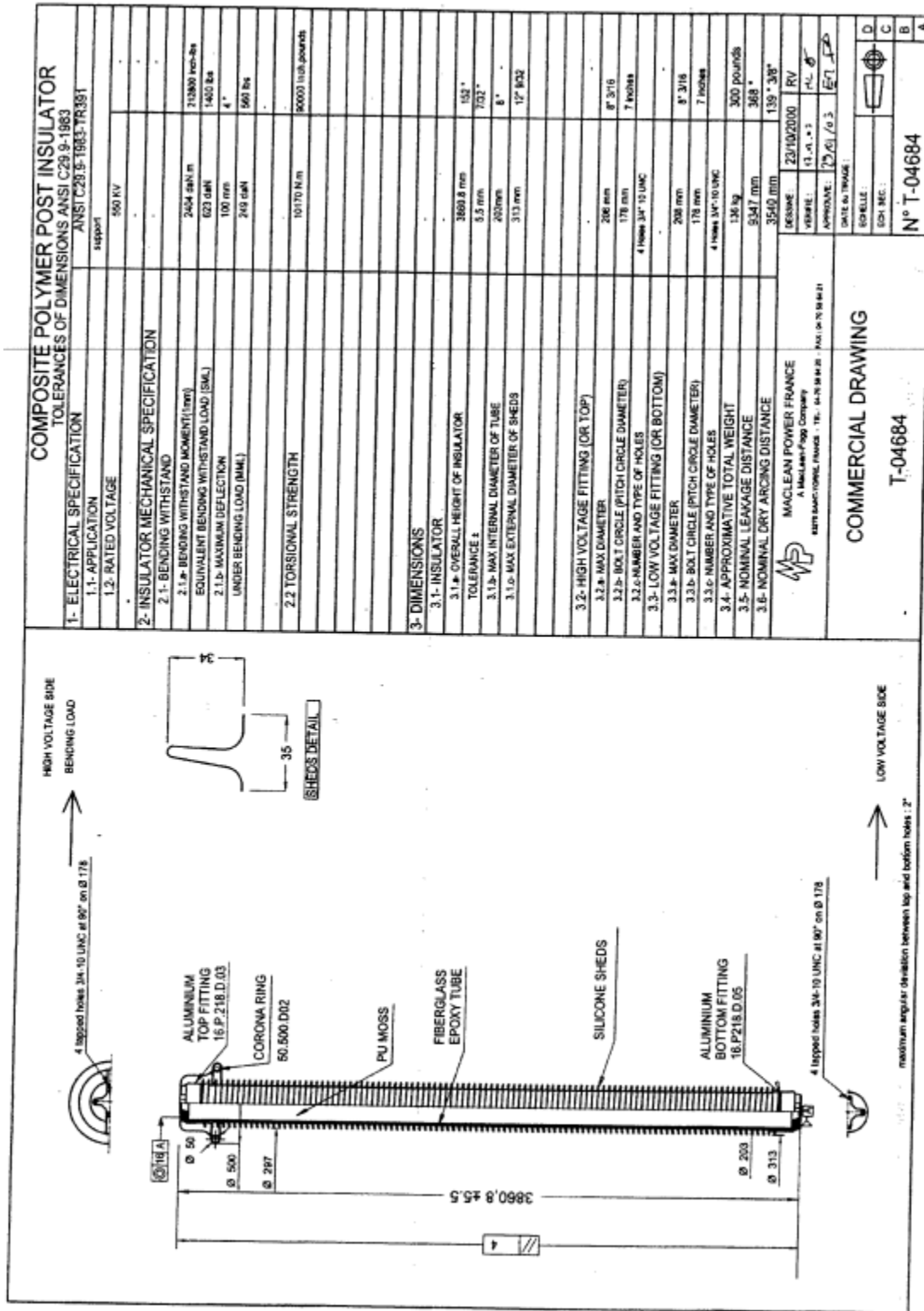

Appendix 2: High Voltage Overhead Transmission

Attachment 1: APPLICABLE STANDARD FRAMING AND ASSEMBLY DRAWINGS

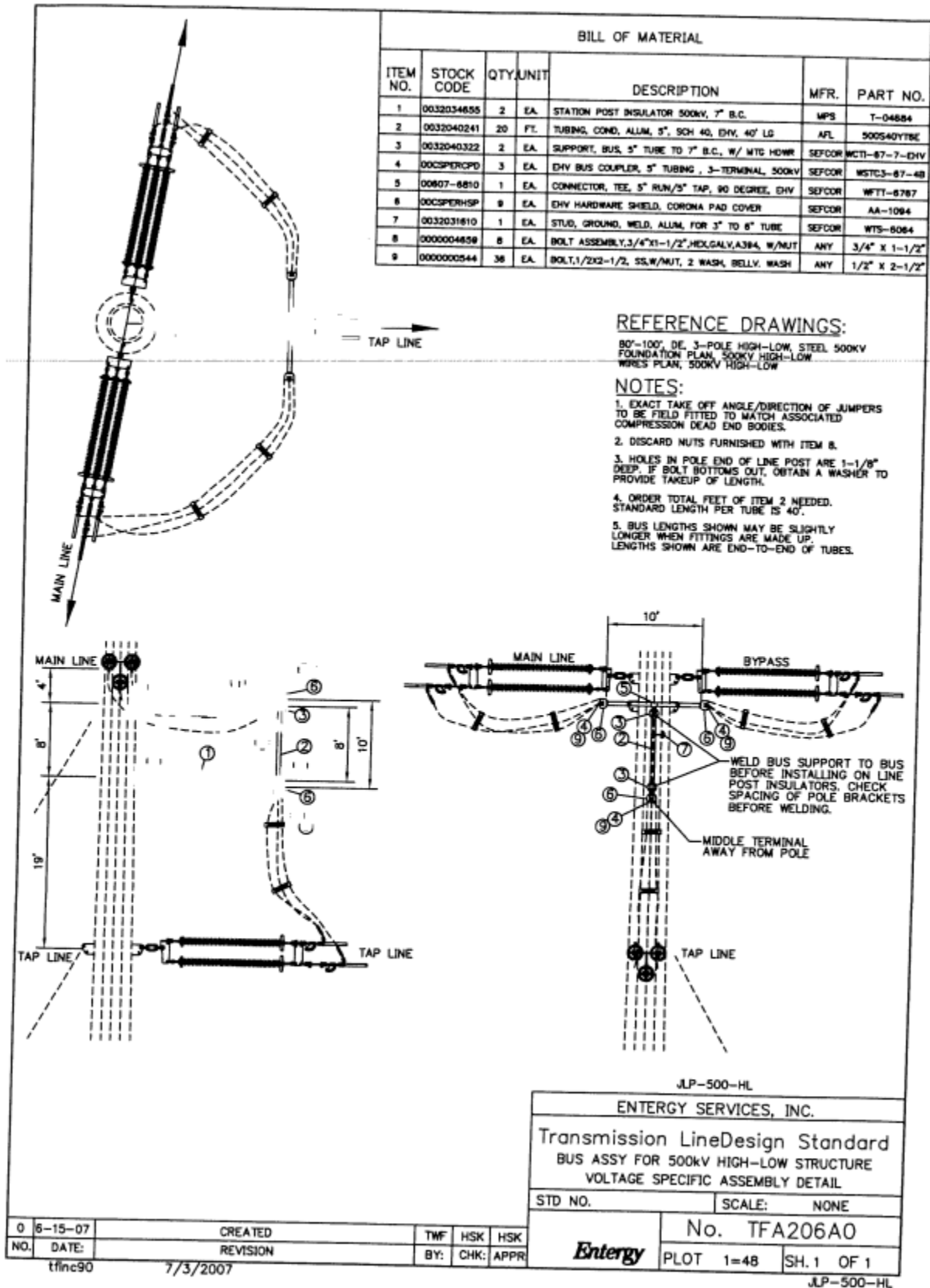

Appendix 2: High Voltage Overhead Transmission

Attachment 1: APPLICABLE STANDARD FRAMING AND ASSEMBLY DRAWINGS

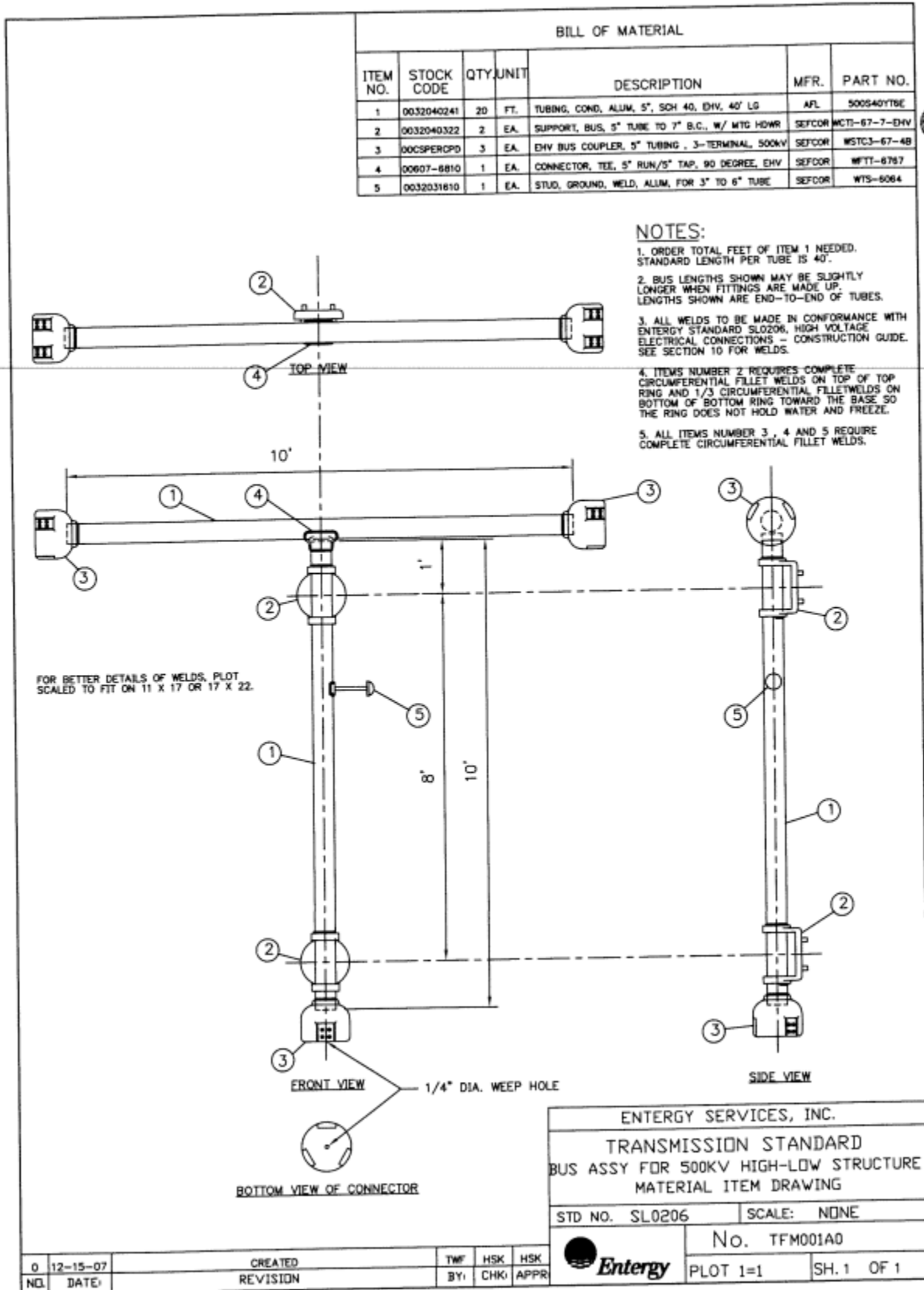

Appendix 2: High Voltage Overhead Transmission

Attachment 1: APPLICABLE STANDARD FRAMING AND ASSEMBLY DRAWINGS

Vang Details for Steel Poles

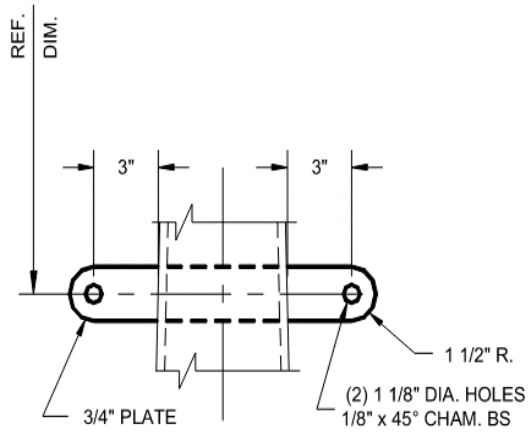

LIGHT-DUTY 2-HOLE VANG

Primary uses:

- Support shield wire span guys
- Support top of braced-post insulator assemblies
- Support conductor swinging angle assemblies

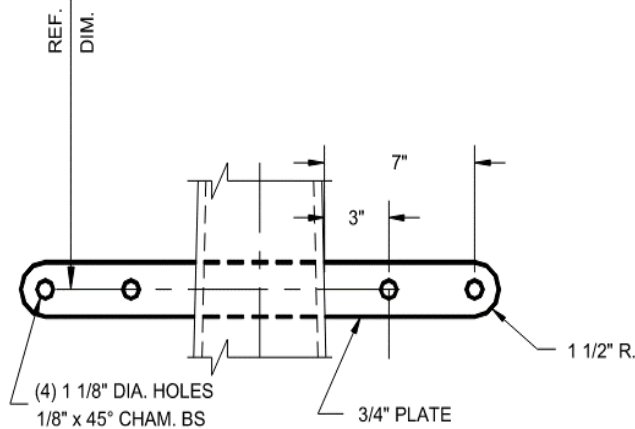

LIGHT-DUTY 4-HOLE VANG

Primary use:

- Support shield wire suspension

This document is the property of Entergy Services, Inc. and contains confidential and proprietary information owned by Entergy Services, Inc. Any copying, use, or disclosure of this information without the written permission of Entergy Services, Inc. is strictly prohibited. This material is protected under trade secret and unfair competition laws and the expression of the information contained herein is protected under Federal copyright laws. Violations thereof may result in criminal penalties and fines.

Copyright Unpublished Work Entergy Services, Inc.
All Rights Reserved

Appendix 2: High Voltage Overhead Transmission

Attachment 1: APPLICABLE STANDARD FRAMING AND ASSEMBLY DRAWINGS

Vang Details for Steel Poles

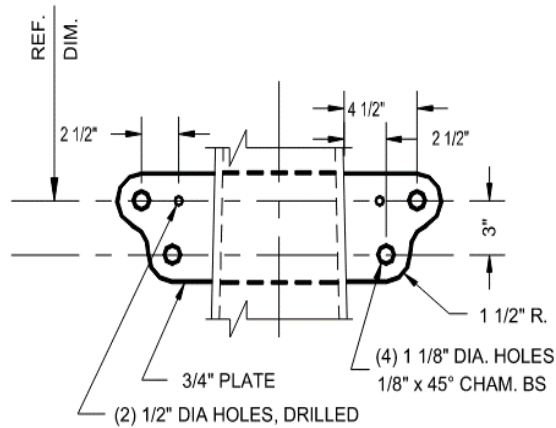

HEAVY-DUTY 4-HOLE VANG

Primary use:

- Support shield wire deadend assemblies
- Support conductor deadend assemblies
- Support conductor deadend down guys
- Support conductor bisector down guys
- Support shield wire deadend down guys
- Support shield wire bisector down guys
- All conductor and shield wire vangs on structures with running angle insulators (E, F and G)

This document is the property of Entergy Services, Inc. and contains confidential and proprietary information owned by Entergy Services, Inc. Any copying, use, or disclosure of this information without the written permission of Entergy Services, Inc. is strictly prohibited. This material is protected under trade secret and unfair competition laws and the expression of the information contained herein is protected under Federal copyright laws. Violations thereof may result in criminal penalties and fines.

Copyright Unpublished Work Entergy Services, Inc.
All Rights Reserved

Appendix 2: High Voltage Overhead Transmission

Attachment 1: APPLICABLE STANDARD FRAMING AND ASSEMBLY DRAWINGS

Vang Details for Steel Poles

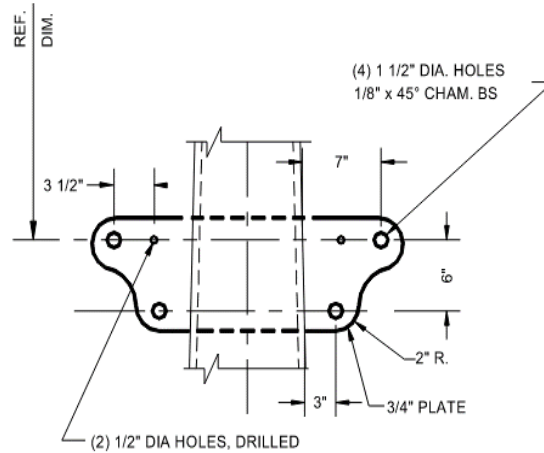

HEAVY-DUTY 4-HOLE VANG FOR TRIPLE BUNDLE SINGLE POINT DEAD ENDS

Primary use:

Support 500kv conductor dead end assemblies where guys will be at the same elevation as the conductors and when guys are not specified.

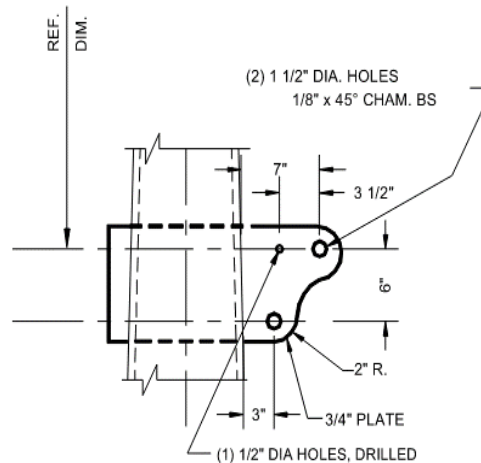

HEAVY-DUTY 2-HOLE VANG FOR TRIPLE BUNDLE SINGLE POINT DEAD ENDS

Primary use:

Support 500kv conductor dead end assemblies and guys where guys are specified and will attach at locations below the conductors. Do not install guy vangs on unguyed structures with this type of vang unless specified by Entergy.

This document is the property of Entergy Services, Inc. and contains confidential and proprietary information owned by Entergy Services, Inc. Any copying, use, or disclosure of this information without the written permission of Entergy Services, Inc. is strictly prohibited. This material is protected under trade secret and unfair competition laws and the expression of the information contained herein is protected under Federal copyright laws. Violations thereof may result in criminal penalties and fines.

Copyright Unpublished Work Entergy Services, Inc.
All Rights Reserved

Appendix 2: High Voltage Overhead Transmission

Attachment 1: APPLICABLE STANDARD FRAMING AND ASSEMBLY DRAWINGS

NEMA Pad Details for Steel Poles or Caissons

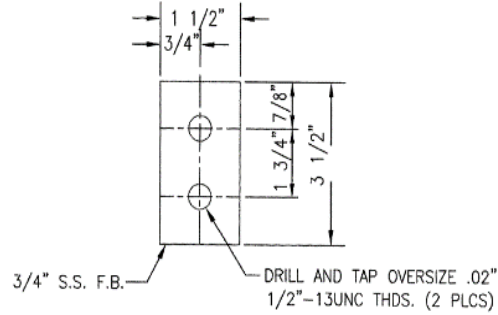

SMALL NEMA 2-HOLE PAD

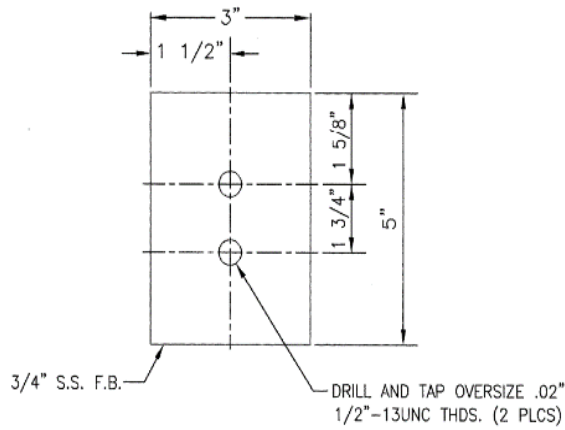

LARGE NEMA 2-HOLE PAD

This document is the property of Entergy Services, Inc. and contains confidential and proprietary information owned by Entergy Services, Inc. Any copying, use, or disclosure of this information without the written permission of Entergy Services, Inc. is strictly prohibited. This material is protected under trade secret and unfair competition laws and the expression of the information contained herein is protected under Federal copyright laws. Violations thereof may result in criminal penalties and fines.

Copyright Unpublished Work Entergy Services, Inc.
All Rights Reserved

Appendix 2: High Voltage Overhead Transmission

Attachment 1: APPLICABLE STANDARD FRAMING AND ASSEMBLY DRAWINGS

Climbing Details

TDS106A1, Step Bolt Details, represents the Entergy specifications for pole steps.

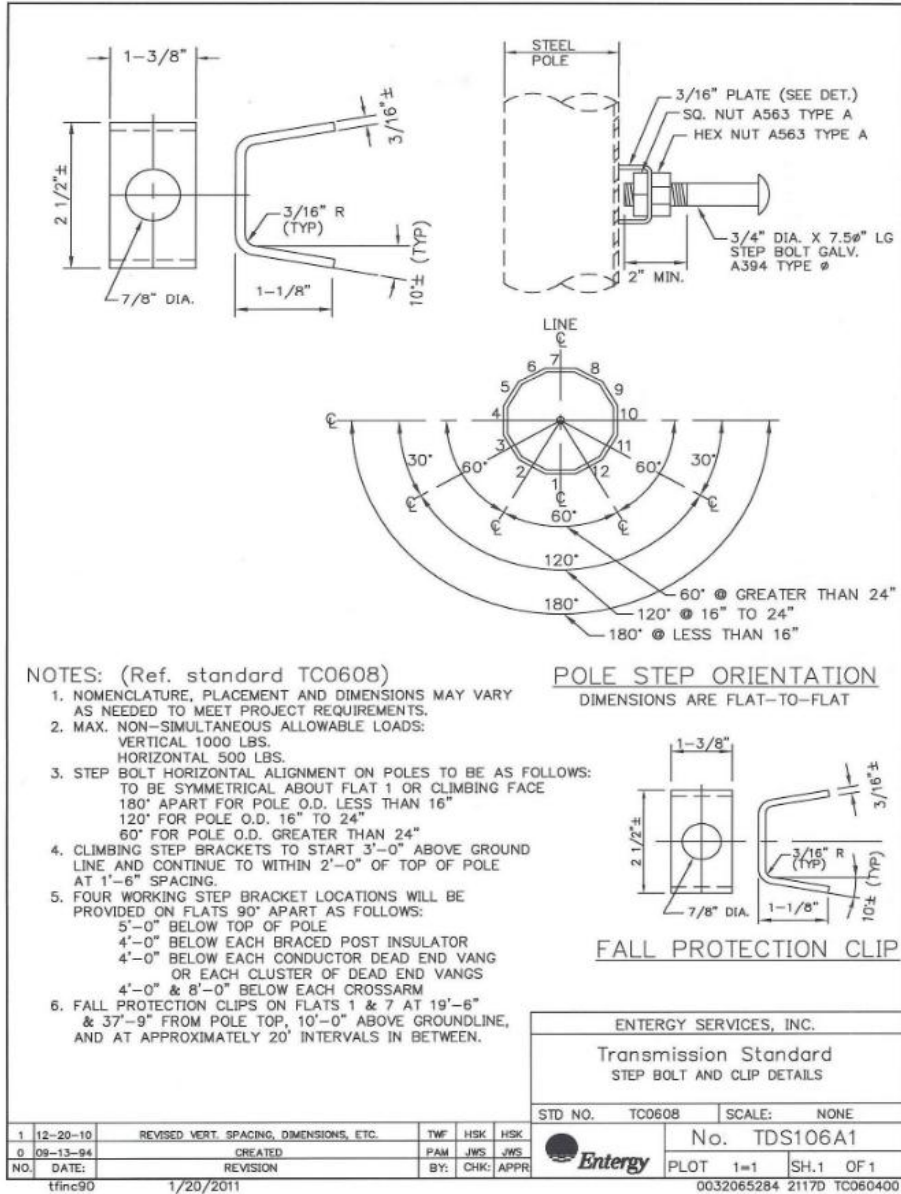

This document is the property of Entergy Services, Inc. and contains confidential and proprietary information owned by Entergy Services, Inc. Any copying, use, or disclosure of this information without the written permission of Entergy Services, Inc. is strictly prohibited. This material is protected under trade secret and unfair competition laws and the expression of the information contained herein is protected under Federal copyright laws. Violations thereof may result in criminal penalties and fines.

Copyright Unpublished Work Entergy Services, Inc.
All Rights Reserved

Appendix 2: High Voltage Overhead Transmission

Attachment 1: APPLICABLE STANDARD FRAMING AND ASSEMBLY DRAWINGS

BILL OF MATERIAL			
ITEM	QTY.	STOCK NO.	DESCRIPTION
1	1	NONE	SIGN, SLOW-VEHICLE, ACQUIRED BY LOCAL PURCHASE
2	8 FT.	0000017124	BAND, STRAPPING, 3/4" WD X 100FT LG ROLL, STAINLESS STEEL, 201
3	2	0032047234	BRACKET, BANDING, FLARED LEG, SS, WITH ONE 5/16"-18 X 3/4" HEX HEAD SS BOLT AND FIBER WASHER, 3/4" SLOT, SHIPPED 50/BOX
4	2	0000017123	BOLT, CLAMP ASSEMBLY, CARRIAGE HD, GALVANIZED STEEL, HIGH STRENGTH, ASTM B221 MILITARY QQ-A-200/8, 5 GR, 3/8" DIA, 6" LG HIGH STR CARR BOLT, WASH AND NUT.

The diagram illustrates the structural assembly for marking a line crossing. It shows a series of poles with signs placed on the third and fourth poles from the crossing. An inset provides a detailed view of the sign assembly, which includes a triangular sign with diagonal hatching, secured to the pole with a bracket and a clamp assembly. The sign is positioned to be visible from the direction of travel.

NOTES:

- 1) This installation is optional with the grids, and represents a standard for uniformity across the system wherever it is used.
- 2) Install one slow-vehicle sign on third & fourth structures on each side of overhead line crossings of lines to be patrolled by helicopter to provide advance warning of aerial hazard ahead. Additional structures may be marked where sight distance or visibility is limited.
- 3) Place the markers near the pole tops and away from the hazard so it will be seen as the helicopter approaches the line crossing.
- 4) Slow-vehicle signs are available for local purchase at farm supply stores and major hardware stores.
- 5) If there are two overhead line crossings in close proximity of each other, install two markers one above the other on each structure. Some structures in between may require single markers on both sides of each structure.
- 6) Fasten markers to poles with 3/4" banding as indicated in the Bill of Material above. Wooden poles may have the markers fastened with galvanized lag screws, 1/4" by 2-1/2" and washers. Additional holes or enlarged holes may be necessary in the marker.
- 7) On wooden poles, do not install hardware cloth over the face of the markers.

SGN-HAZ-XNG
ENTERGY SERVICES, INC.
 Transmission Line Design Standard
 LINE CROSSING HAZARD MARKING
 STRUCTURAL ASSEMBLY DETAIL

STD NO.	SCALE: NONE
No. TMD407A0	
PLOT 1=1 SH. 1 OF 1	

0	12-10-08	CREATED	TWF	HSK	HSK
NO.	DATE:	REVISION	BY:	CHK:	APPR
	tfinc90	12/11/2008			

Appendix 2: High Voltage Overhead Transmission

Attachment 1: APPLICABLE STANDARD FRAMING AND ASSEMBLY DRAWINGS

BILL OF MATERIAL			
ITEM	QTY.	STOCK NO.	DESCRIPTION
1	4	0032045036	DAMPER, VIBRATION, SPIRAL, YELLOW, FOR 3/8" HSG & 7#7 AW CDR
2	6	0032054555	PROTECTOR, WILDLIFE, BIRD, 10" DIA, PLASTIC, ORANGE COLOR WITH REFLECTIVE PANELS ON BOTH SIDES, AND CONDUCTOR CLAMPS. QUIKMARK 10-R

FLIGHT

SW OF CROSSING LINE

C SW C SW C

FLIGHT

SPIRAL DAMPER

1

SW OF CROSSING LINE

QUIKMARK 10-R

2

QUIKMARK 10-R

VERTICAL ABOVE OUTSIDE PHASES

E.T.L.

NOTES:

- 1) This installation is optional with the grids, and represents a standard for uniformity across the system wherever it is used.
- 2) Install these exact quantities when possible. If variance is needed, maintain symmetry about the centerline.
- 3) Place the inside QUIKMARK 10-R's immediately above the outside conductors, but not closer than 15 feet apart.
- 4) Place the dampers between the QUIKMARK 10-R's and about 1 foot from them.
- 5) If there are 2 overhead shield wires crossing the Entergy line, place half the devices on each wire unless the owner specifies differently.

SGN-HAZ-OHG

ENTERGY SERVICES, INC.	
Transmission Line Design Standard OVERHEAD GROUND HAZARD MARKING STRUCTURAL ASSEMBLY DETAIL	
STD NO.	SCALE: NONE
No. TMD406A0	
PLOT 1=1 SH. 1 OF 1	

SGN-HAZ-OHG

0	12-10-08	CREATED	TWF	HSK	HSK
NO.	DATE:	REVISION	BY:	CHK:	APPR:
	tfinc90	12/11/2008			

Appendix 2: High Voltage Overhead Transmission

Attachment 1: APPLICABLE STANDARD FRAMING AND ASSEMBLY DRAWINGS

BILL OF MATERIAL			
ITEM	QTY.	STOCK NO.	DESCRIPTION
1	1	0032048218	NUMBER, BLANK, 10" X 14", POLYPROPYLENE, ALL YELLOW BACKGROUND, 0.23" TH
2	1	0032048221	NUMBER, BLANK, 10" X 14", POLYPROPYLENE, ALL RED BACKGROUND, 0.23" TH
3	1	0032048222	BRACKET, AERIAL NUMBER, ALUM, 30" LG, FOR 2 10"X14" EVERLAST PLAQUES
4	8 FT.	0000017124	BAND, STRAPPING, 3/4" WD X 100FT LG ROLL, STAINLESS STEEL, 201
5	2	0032047234	BRACKET, BANDING, FLARED LEG, SS, WITH ONE 5/16"-18 X 3/4" HEX HEAD SS BOLT AND FIBER WASHER, 3/4" SLOT, SHIPPED 50/BOX
6	2	0000017123	BOLT, CLAMP ASSEMBLY, CARRIAGE HD, GALVANIZED STEEL, HIGH STRENGTH, ASTM B221 MILITARY QQ-A-200/8, 5 GR, 3/8" DIA, 6" LG HIGH STR CARR BOLT, WASH AND NUT.

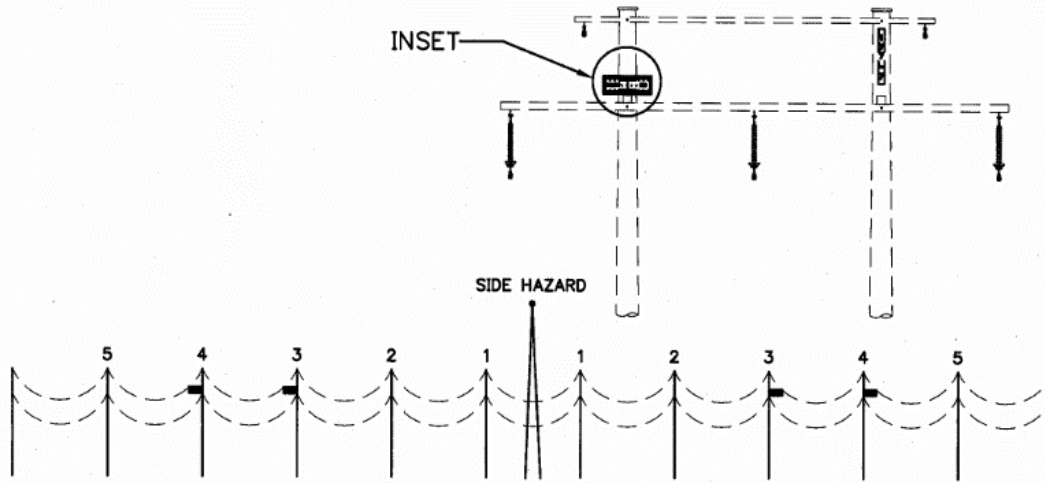

NOTES:

- 1) This installation is optional with the grids, and represents a standard for uniformity across the system wherever it is used.
- 2) Install one adjacent hazard marker on third & fourth structures on each side of the hazard adjacent to lines to be patrolled by helicopter to provide advance warning of adjacent hazard ahead. Additional structures may be marked where sight distance or visibility is limited.
- 3) Place the markers near the pole tops and away from the hazard so it will be seen as the helicopter approaches the hazard.
- 4) Adjacent-hazard markers are available from Entergy stores or directly from Tech Products, Inc., by white-req.
- 5) Fasten markers to poles with 3/4" banding as indicated in the Bill of Material above. Wooden poles may have the markers fastened with galvanized lag screws, 1/4" by 2-1/2" and washers. Additional holes or enlarged holes may be necessary in the plastic marker.
- 6) On wooden poles, do not install hardware cloth over the face of the markers.

INSET

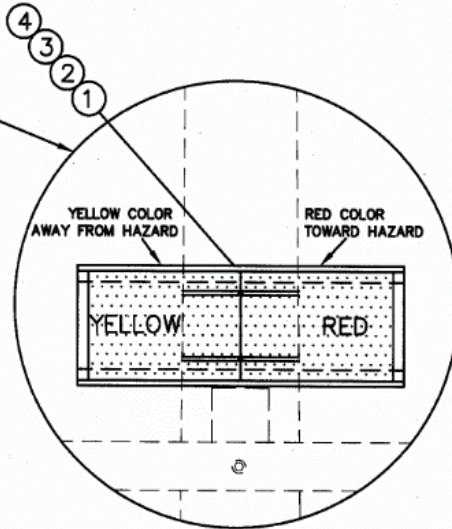

SGN-HAZ-ADJ

ENTERGY SERVICES, INC.

Transmission Line Design Standard
ADJACENT HAZARD MARKING
STRUCTURAL ASSEMBLY DETAIL

STD NO.

SCALE: NONE



No. TMD408A0

PLOT 1=1

SH.1 OF 1

SGN-HAZ-ADJ

0	12-10-08	CREATED	TWF	HSK	HSK
NO.	DATE:	REVISION	BY:	CHK:	APPR
	tfinc90	12/11/2008			

Appendix 2: High Voltage Overhead Transmission

Attachment 1: APPLICABLE STANDARD FRAMING AND ASSEMBLY DRAWINGS

BILL OF MATERIAL			
ITEM	QTY.	STOCK NO.	DESCRIPTION
1	1	0032054553	LETTER, "S", 10" X 14", BLACK ON YELLOW, TECH PRODUCTS PART NUMBER EL 12KYS
2	8 FT.	0000017124	BAND, STRAPPING, 3/4" WD X 100FT LG ROLL, STAINLESS STEEL, 201
3	2	0032047234	BRACKET, BANDING, FLARED LEG, SS, WITH ONE 5/16"-18 X 3/4" HEX HEAD SS BOLT AND FIBER WASHER, 3/4" SLOT, SHIPPED 50/BOX
4	2	0000017123	BOLT, CLAMP ASSEMBLY, CARRIAGE HD, GALVANIZED STEEL, HIGH STRENGTH, ASTM B221 MILITARY QQ-A-200/8, 5 GR, 3/8" DIA, 6" LG HIGH STR CARR BOLT, WASH AND NUT.

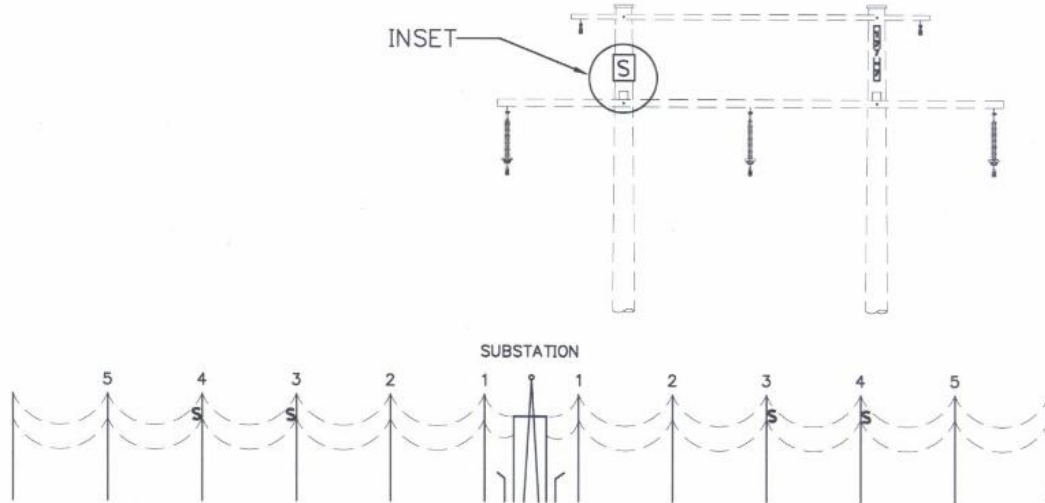

NOTES:

- 1) This installation is optional with the grids, and represents a standard for uniformity across the system wherever it is used.
- 2) Install one substation hazard marker on third & fourth structures on each side of the substation with hazard along lines to be patrolled by helicopter to provide advance warning of potential hazard ahead. Additional structures may be marked where sight distance or visibility is limited.
- 3) Place the markers near the pole tops and away from the substation so it will be seen as the helicopter approaches the substation
- 4) Substation hazard markers are available from Tech Products, Inc., EL12KYS.
- 5) Fasten markers to poles with 3/4" banding as indicated in the Bill of Material above. Wooden poles may have the markers fastened with galvanized lag screws, 1/4" by 2-1/2" and washers. Additional holes or enlarged holes may be necessary in the marker.
- 6) On wooden poles, do not install hardware cloth over the face of the markers.

INSET

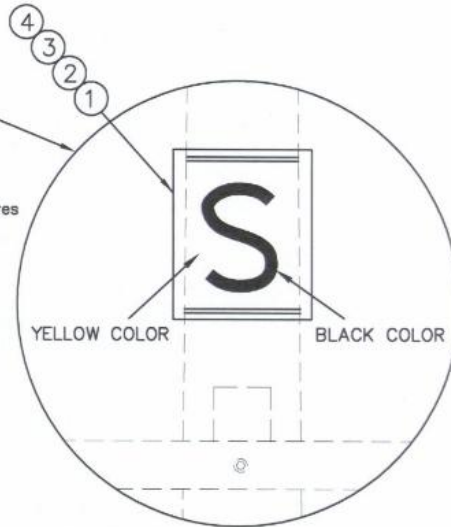

SGN-HAZ-SUB

ENTERGY SERVICES, INC.	
Transmission Line Design Standard	
SUBSTATION HAZARD MARKINGS	
STRUCTURAL ASSEMBLY DETAIL	
STD NO.	SCALE: NONE
No. TMD409A0	
PLOT 1=1	SH. 1 OF 1

0	12-10-08	CREATED	TWF	HSK	HSK
NO.	DATE:	REVISION	BY:	CHK:	APPR
tfinc90		12/11/2008			

Appendix 2: High Voltage Overhead Transmission

Attachment 2: NESC AND ENTERGY CLEARANCE REQUIREMENTS

Basic NESC Clearance Requirements

Rule 230A2, Emergency Vertical Clearances to Ground							
	69	115	138	161	230	345	500
Truck Accessible	16.2	17.1	17.6	18.0	19.4	21.7	24.9
Pedestrian Only	9.7	10.6	11.1	11.5	12.9	15.2	18.4

RULE 232B&C - Vertical Clearance over Ground, Roadway, Rail or Water Surfaces							
	69	115	138	161	230	345	500
Railroad	27.16	28.09	28.56	29.02	30.41	32.74	35.87
Roads	19.16	20.09	20.56	21.02	22.41	24.74	27.87
Other Area Traversed by Vehicles	19.16	20.09	20.56	21.02	22.41	24.74	27.87
Accessible to Pedestrian Traffic Only	15.16	16.09	16.56	17.02	18.41	20.74	23.87

RULE 233C - Vertical Clearance over Another Wire With or Without Wind							
	69	115	138	161	230	345	500
0	2.66	3.59	4.06	4.52	5.91	8.24	11.85
13.8	2.93	3.86	4.32	4.79	6.18	8.50	12.12
34.5	3.32	4.25	4.72	5.18	6.58	8.90	12.52
69	4.06	4.98	5.45	5.91	7.31	9.63	13.25
115	4.98	5.91	6.38	6.84	8.24	10.56	14.18
138	5.45	6.38	6.84	7.31	8.70	11.03	14.64
161	5.91	6.84	7.31	7.77	9.17	11.49	15.10
230	7.31	8.24	8.70	9.17	10.56	12.89	16.50
345	9.63	10.56	11.03	11.49	12.89	15.21	18.82
500	13.25	14.18	14.64	15.10	16.50	18.82	22.44

RULE 234B, C & G - Vertical Clearance over Various Structures							
	69	115	138	161	230	345	500
Lighting Supports	5.23	6.16	6.62	7.09	8.48	10.80	13.94
Traffic Signal Supports	5.23	6.16	6.62	7.09	8.48	10.80	13.94

Appendix 2: High Voltage Overhead Transmission

Attachment 2: NESC AND ENTERGY CLEARANCE REQUIREMENTS

Supporting Structures of Other Lines	5.23	6.16	6.62	7.09	8.48	10.80	13.94
Intermediate Poles in Skip-Span Construction	5.23	6.16	6.62	7.09	8.48	10.80	13.94
Building Roofs not Accessible to Pedestrians	13.16	14.09	14.56	15.02	16.41	18.74	21.87
Building Areas Accessible to Pedestrians	14.16	15.09	15.56	16.02	17.41	19.74	22.87
Building Areas Accessible to Vehicles (not Trucks)	14.16	15.09	15.56	16.02	17.41	19.74	22.87
Building Areas Accessible to Trucks	19.16	20.09	20.56	21.02	22.41	24.74	27.87
Signs, Chimneys, Billboards, Radio and TV antennas, Flagpoles and Flags, Banners, Tanks with Catwalks	14.16	15.09	15.56	16.02	17.41	19.74	22.87
Signs, Chimneys, Billboards, Radio and TV antennas, Flagpoles and Flags, Banners, Tanks without Catwalks	8.66	9.59	10.06	10.52	11.91	14.24	17.37

RULE 234B, C & G - Horizontal Clearance to Various Structures with No Wind							
	69	115	138	161	230	345	500
Lighting Supports	5.00	5.66	6.12	6.59	7.98	10.30	13.44
Traffic Signal Supports	5.00	5.66	6.12	6.59	7.98	10.30	13.44
Supporting Structures of Other Lines	5.00	5.66	6.12	6.59	7.98	10.30	13.44
Intermediate Poles in Skip Span Construction	5.00	5.66	6.12	6.59	7.98	10.30	13.44
Buildings	8.16	9.09	9.56	10.02	11.41	13.74	16.87
Signs, Chimneys, Billboards,	8.16	9.09	9.56	10.02	11.41	13.74	16.87
Radio and TV Antennas, Flagpoles & Flags	8.16	9.09	9.56	10.02	11.41	13.74	16.87
Banners, Tanks	8.16	9.09	9.56	10.02	11.41	13.74	16.87

RULE 234B, C & G - Horizontal Clearance to Various Structures with Wind							
	69	115	138	161	230	345	500

Appendix 2: High Voltage Overhead Transmission

Attachment 2: NESC AND ENTERGY CLEARANCE REQUIREMENTS

Lighting Supports	5.16	6.09	6.56	7.02	8.41	10.74	13.87
Traffic Signal Supports	5.16	6.09	6.56	7.02	8.41	10.74	13.87
Supporting Structures of Other Lines	5.16	6.09	6.56	7.02	8.41	10.74	13.87
Intermediate Poles in Skip Span Construction	5.16	6.09	6.56	7.02	8.41	10.74	13.87
Buildings	5.16	6.09	6.56	7.02	8.41	10.74	13.87
Signs, Chimneys, Billboards,	5.16	6.09	6.56	7.02	8.41	10.74	13.87
Radio and TV Antennas, Flagpoles & Flags	5.16	6.09	6.56	7.02	8.41	10.74	13.87
Banners, Tanks	5.16	6.09	6.56	7.02	8.41	10.74	13.87

RULE 235C2b1 - Vertical Clearance Between Wires Supported at Different Levels on the Same Structures							
	69	115	138	161	230	345	500
0	2.03	2.58	3.02	3.47	4.79	7.01	9.99
13.8	2.03	2.85	3.29	3.73	5.06	7.27	10.25
34.5	2.36	3.24	3.69	4.13	5.46	7.67	10.65
69	3.02	3.91	4.35	4.79	6.12	8.33	11.32
115	3.91	4.79	5.24	5.68	7.01	9.22	12.20
138	4.35	5.24	5.68	6.12	7.45	9.66	12.64
161	4.79	5.68	6.12	6.56	7.89	10.10	13.09
230	6.12	7.01	7.45	7.89	9.22	11.43	14.42
345	8.33	9.22	9.66	10.10	11.43	13.65	16.63
500	11.32	12.20	12.64	13.09	14.42	16.63	19.61

Appendix 2: High Voltage Overhead Transmission

Attachment 2: NESC AND ENTERGY CLEARANCE REQUIREMENTS

RULE 235B - Horizontal Clearance Between Wires Supported on the Same Structure							
	69	115	138	161	230	345	500
0	2.08	2.96	3.41	3.85	5.18	7.39	10.37
13.8	2.34	3.23	3.67	4.11	5.44	7.66	10.64
34.5	2.74	3.63	4.07	4.51	5.84	8.05	11.04
69	3.41	4.29	4.73	5.18	6.50	8.72	11.70
115	4.29	5.18	5.62	6.06	7.39	9.60	12.59
138	4.73	5.62	6.06	6.50	7.83	10.05	13.03
161	5.18	6.06	6.50	6.95	8.27	10.49	13.47
230	6.50	7.39	7.83	8.27	9.60	11.82	14.80
345	8.72	9.60	10.05	10.49	11.82	14.03	17.01
500	11.70	12.59	13.03	13.47	14.80	17.01	20.00

RULE 233B1 - Horizontal Clearance to Other Wires (With or without Wind)							
	69	115	138	161	230	345	500
0	5.66	6.59	7.06	7.52	8.91	11.24	14.37
13.8	5.94	6.87	7.33	7.80	9.19	11.52	14.65
34.5	6.36	7.29	7.75	8.22	9.61	11.94	15.07
69	7.06	7.98	8.45	8.91	10.31	12.63	15.76
115	7.98	8.91	9.38	9.84	11.24	13.56	16.69
138	8.45	9.38	9.84	10.31	11.70	14.03	17.16
161	8.91	9.84	10.31	10.77	12.17	14.49	17.62
230	10.31	11.24	11.70	12.17	13.56	15.89	19.02
345	12.63	13.56	14.03	14.49	15.89	18.21	21.34
500	15.76	16.69	17.16	17.62	19.02	21.34	24.47

Vertical Clearance Requirements; NESC 2012 & Entergy Design Clearance

	69 kV⁽¹⁾		115/138/161 kV⁽¹⁾		230 kV⁽¹⁾		345 kV⁽¹⁾		500 kV⁽¹⁾ (3)	
	NESC ⁽²⁾	ETR	NESC ⁽²⁾	ETR	NESC ⁽²⁾	ETR	NESC ⁽²⁾	ETR	NESC ⁽²⁾	ETR
	@ Max. Sag(ft.)	@ Max. Sag(ft.)	@ Max. Sag(ft.)	@ Max. Sag(ft.)	@ Max. Sag(ft.)	@ Max. Sag(ft.)	@ Max. Sag(ft.)	@ Max. Sag(ft.)	@ Max. Sag(ft.)	@ Max. Sag(ft.)
Railroads	27.16	33.00	29.02	35.00	30.41	37.00	32.74	41.00	35.87	48.00
Roads	19.16	28.00	21.02	30.00	22.41	32.00	24.74	33.00	27.87	40.00
Other Land Traversed by	19.16	24.00	21.02	26.00	22.41	28.00	24.74	33.00	27.87	40.00

Solar BOT Scope Book: Appendix 2 High Voltage Overhead Transmission

Appendix 2: High Voltage Overhead Transmission

Attachment 2: NESC AND ENTERGY CLEARANCE REQUIREMENTS

any kind of Vehicle										
Cultivated Farmland	19.16	27.00	21.02	29.00	22.41	31.00	24.74	33.00	27.87	40.00
Land accessible to pedestrians only	15.16	24.00	17.02	26.00	18.41	28.00	20.74	29.00	23.87	36.00
Water Areas Suitable for sailboats:										
Less than 20 acres	21.16	24.00	23.02	26.00	24.41	28.00	26.74	35.00	29.87	42.00
20-200 acres	29.16	32.00	31.02	34.00	32.41	36.00	34.74	43.00	37.87	50.00
200-2000 acres	35.16	37.00	37.02	40.00	38.41	42.00	40.74	49.00	43.87	56.00
Over 2000 acres	41.16	44.00	43.02	46.00	44.41	48.00	46.74	55.00	49.87	62.00
Sailboat launch sites adjacent to water: Add 5'										
Less than 20 acres	26.16	29.00	28.02	31.00	29.41	33.00	31.74	40.00	34.87	47.00
20-200 acres	34.16	37.00	36.02	39.00	37.41	41.00	39.74	48.00	42.87	53.00
200-2000 acres	40.16	43.00	42.02	45.00	43.41	47.00	45.74	54.00	48.87	61.00
Over 2000 acres	46.16	49.00	48.02	51.00	49.41	53.00	51.74	60.00	54.87	67.00
Other supply lines 34.5kV and under	2.66	8.00	4.52	10.00	5.91	15.00	8.24	17.00	11.85	23.00
Other supply lines:										
69 kV	4.06	10.00	5.91	11.00	7.31	16.00	9.63	18.00	13.25	20.00
115/138/161 kV	5.91	11.00	7.77	13.00	9.17	18.00	11.49	20.00	15.10	22.00
230 kV	7.31	16.00	9.17	18.00	10.56	20.00	12.89	22.00	16.50	24.00
345 kV	9.63	18.00	11.49	20.00	12.89	22.00	15.21	24.00	18.82	26.00
500 kV	13.25	20.00	15.10	22.00	16.50	24.00	18.82	26.00	22.44	28.00
Guys, Neutrals and shield wires	2.66	8.00	4.52	10.00	5.91	15.00	8.24	17.00	11.85	19.00
Communications lines	5.66	10.00	7.52	12.00	8.91	15.00	11.24	17.00	14.37	19.00

Notes:

(1) Conductor Temperature: 100°C for ACSR, see table 7.1(b) for other conductor types

Appendix 2: High Voltage Overhead Transmission

Attachment 2: NESC AND ENTERGY CLEARANCE REQUIREMENTS

- (2) NESC Vertical Clearance = Basic Clearance + Voltage Adder; Voltage Adder = 0.4"/kV in excess of 22kV; refer to 2012 NESC Clearance Calculations.
- (3) For 500 kV, the NESC clearance is approximately equal to the clearance requirements derived from a Switching Surge factor of 2.6.

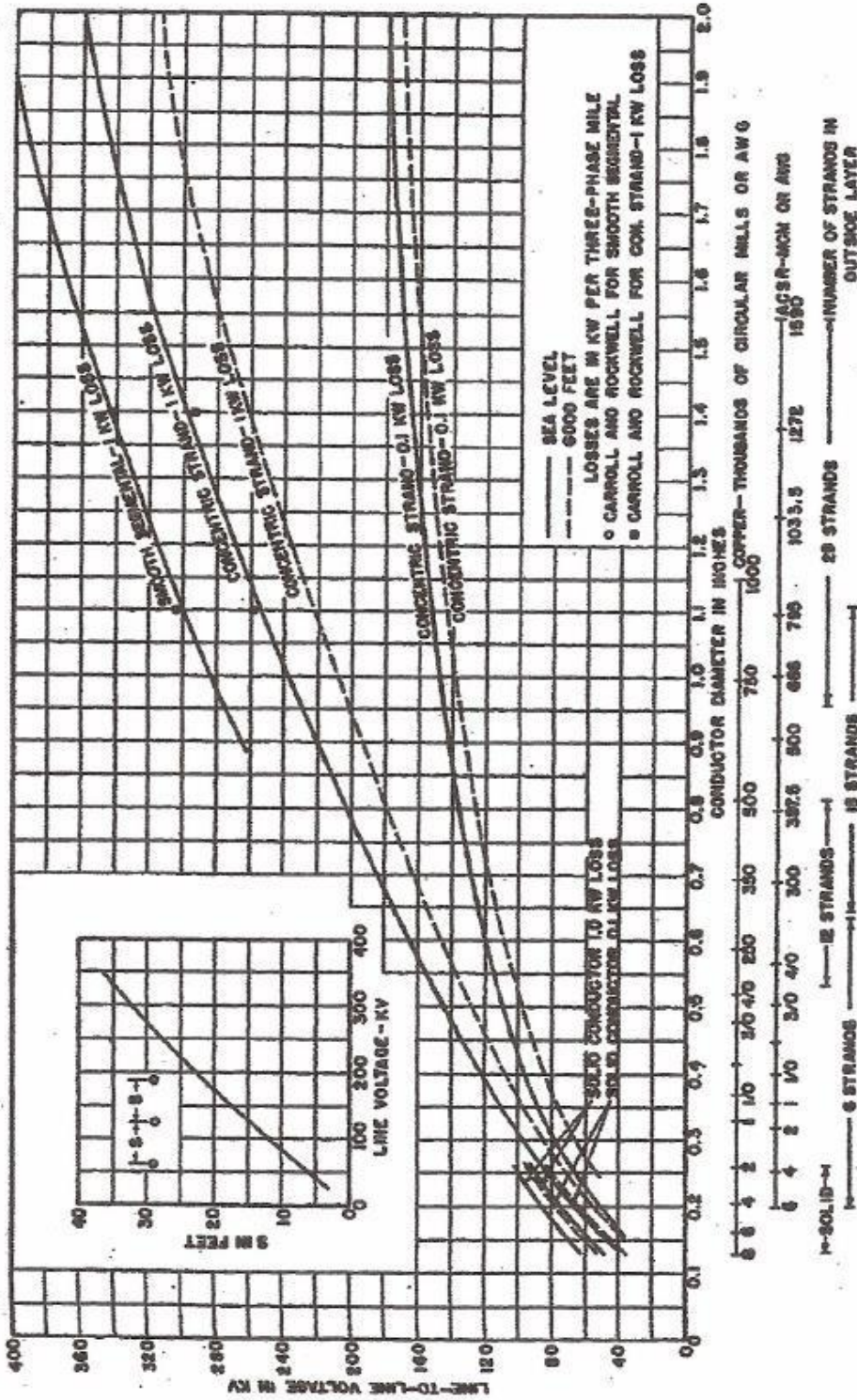
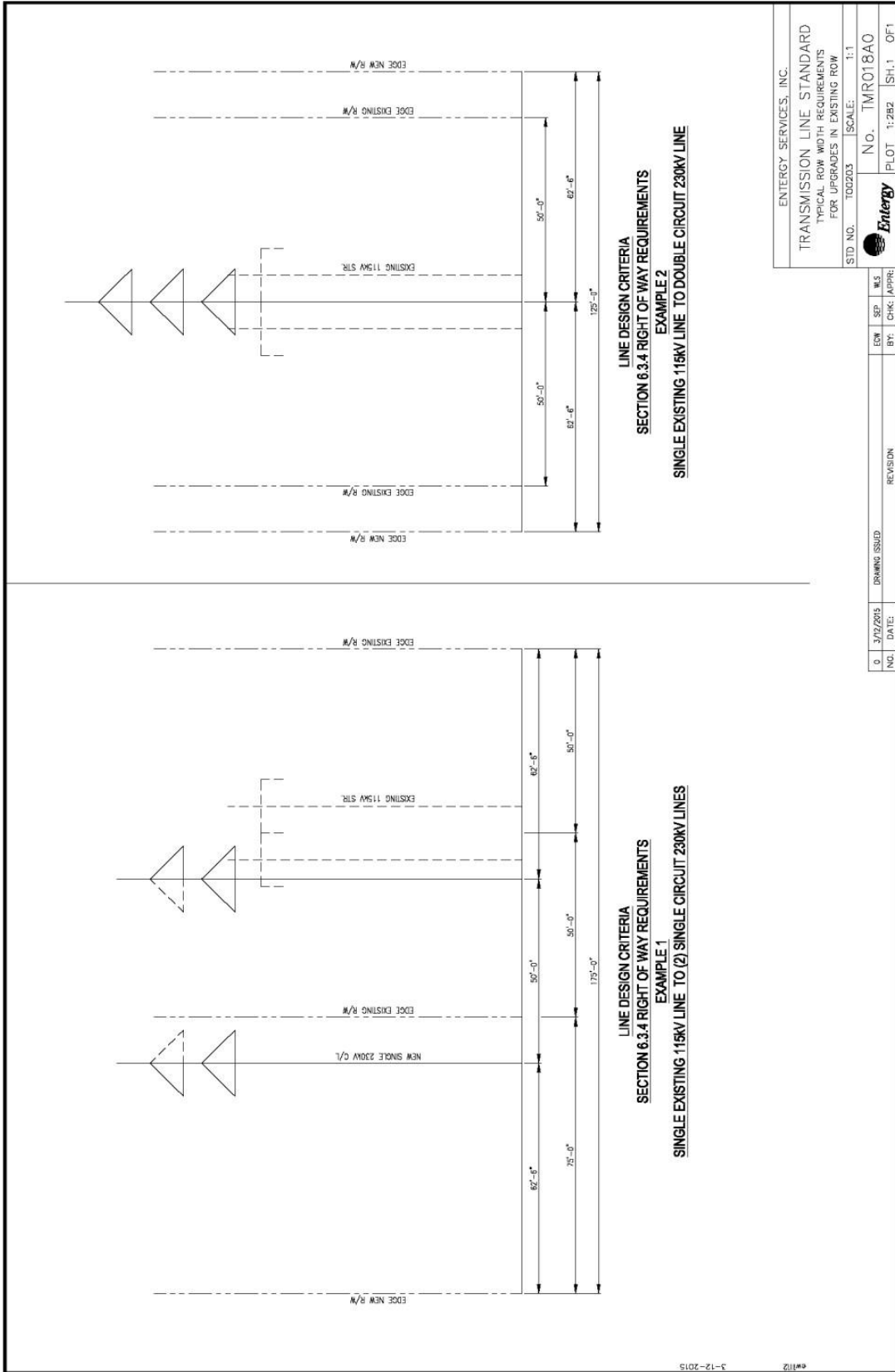

Fig. 31—Quick-Estimating Corona-Loss Curves. Curves based on Peterson's formula with a few check points from the Carrol and Rockwell paper for comparison.

Appendix 2: High Voltage Overhead Transmission

Attachment 4: EXAMPLE ROW



ENERGY SERVICES, INC.	
TRANSMISSION LINE STANDARD	
TYPICAL ROW WIDTH REQUIREMENTS FOR UPGRADES IN EXISTING ROW	
STD. NO. T02203	SCALE: 1:1
No. TM0718A0	
PLOT 1:2B2	SH.1 OF1

0	3/22/2015	DATE:	NO.	REVISION
BY:	CHK:	APPR:	WLS	SEP
EDW	BY:	CHK:	APPR:	WLS
EDW	BY:	CHK:	APPR:	WLS

ENERGY SERVICES, INC.	
TRANSMISSION LINE STANDARD	
TYPICAL ROW WIDTH REQUIREMENTS FOR UPGRADES IN EXISTING ROW	
STD. NO. T02203	SCALE: 1:1
No. TM0718A0	
PLOT 1:2B2	SH.1 OF1

Appendix 2: High Voltage Overhead Transmission

Attachment 4: EXAMPLE ROW

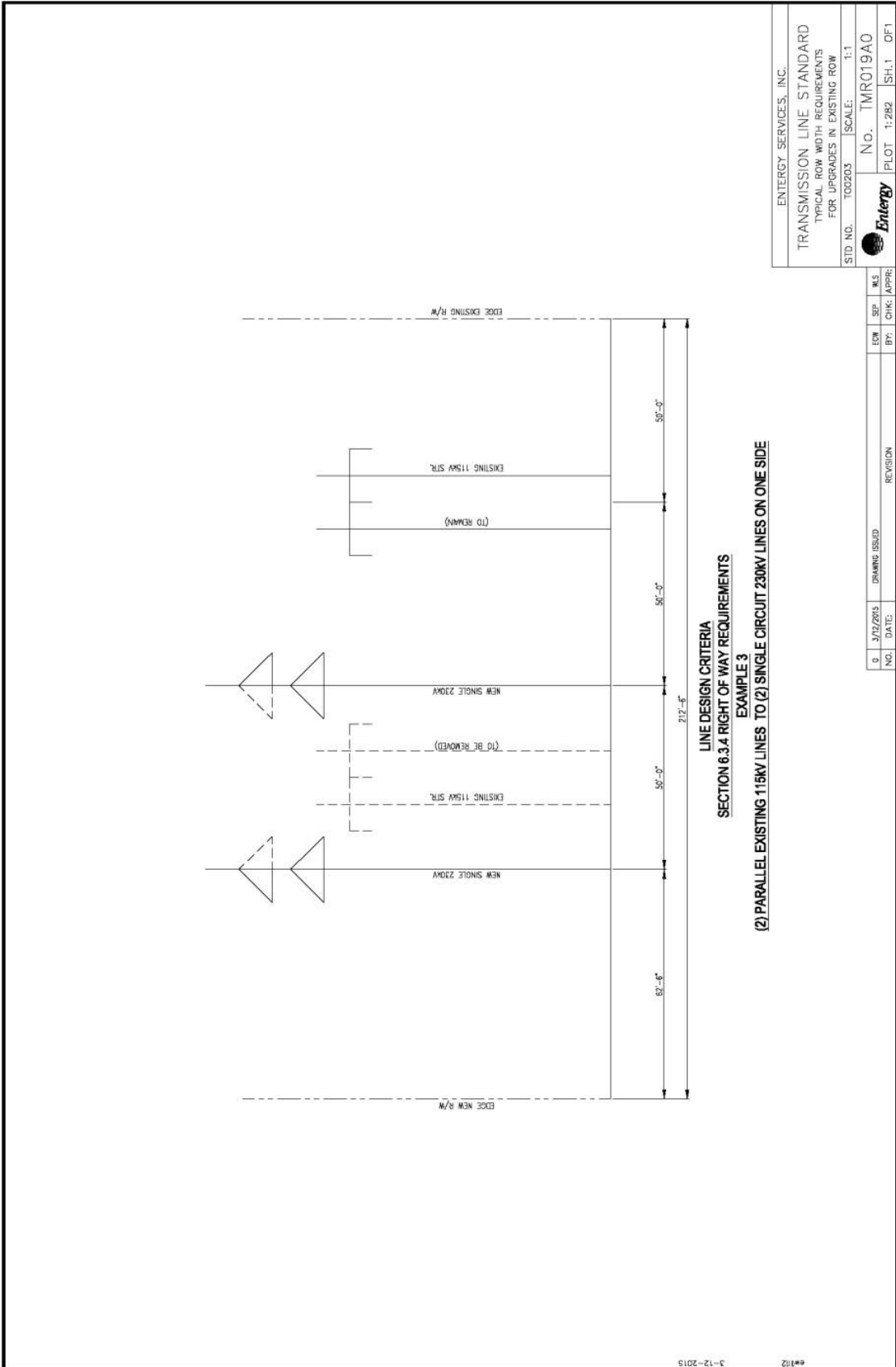

ENTERGY SERVICES, INC.
 TRANSMISSION LINE STANDARD
 TYPICAL ROW WIDTH REQUIREMENTS
 FOR UPGRADES IN EXISTING ROW
 STD. NO. T00203 SCALE: 1:1
 No. TMR019A0
 PLOT 1:282 SH:1 OF1
 100203, ATTACHMENT 6, P. 2 OF 3

0	3/7/2015	DATE	DRIVING ISSUED	REVISION
EW	SP	MS		
BY:	CHK:	APPR:		

Appendix 2: High Voltage Overhead Transmission

Attachment 4: EXAMPLE ROW

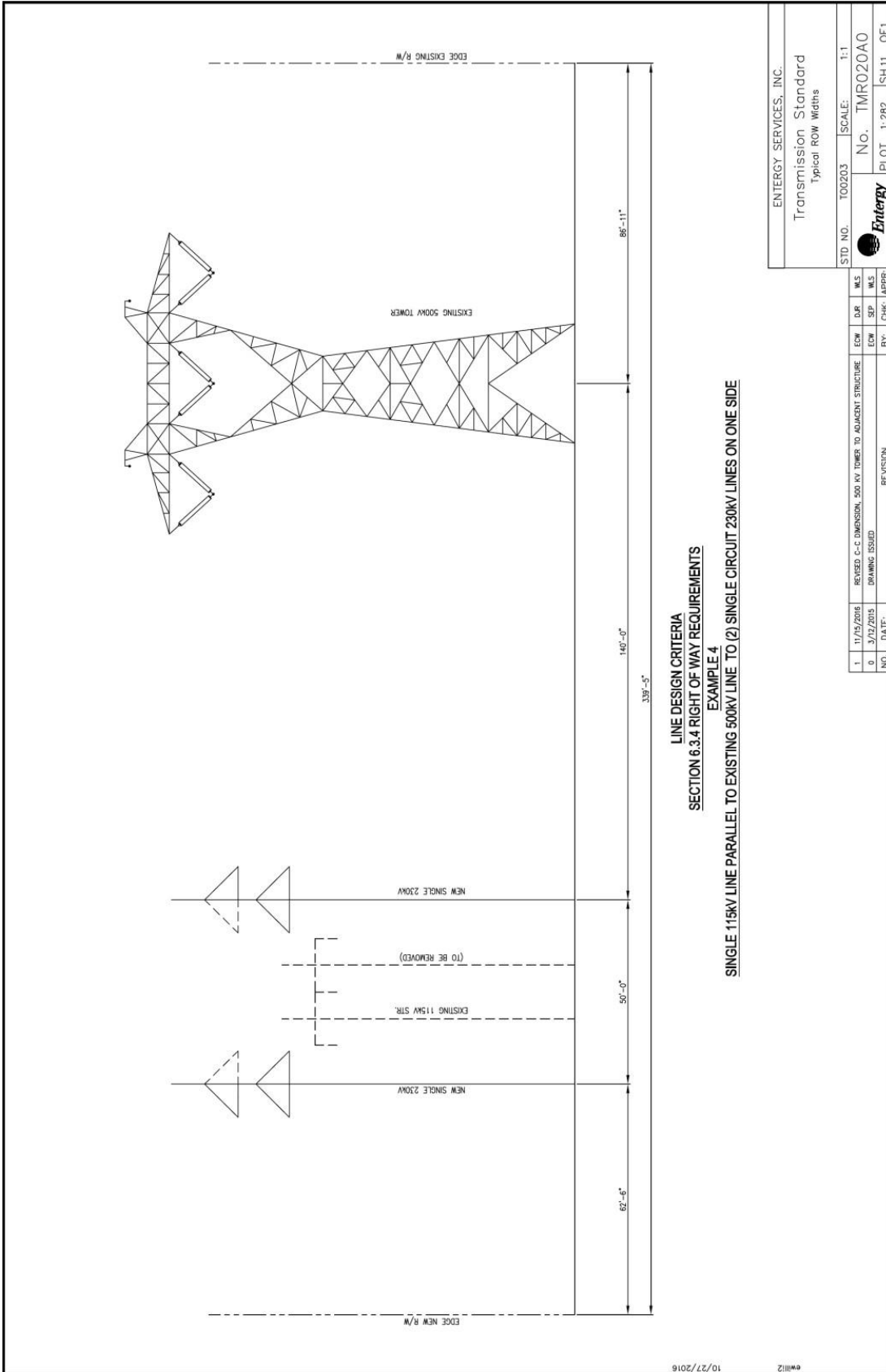

Appendix 2: High Voltage Overhead Transmission

Attachment 5: APPROVED VENDOR LIST

Lead Time					Date last updated: August 22, 2023
Purchase Spec.	Class	Description	Qualifier	Approved Manufacturer(s) ()-Preferred	Preferred Supplier
SA0102	Arresters	Arrester, Surge		(Cooper), Siemens, Hitachi Energy	Series 2000
PM0202	Battery	Batteries	CC	(Energys)	Exponential Power
PM0201	Battery	Batteries	EC	(Energys)	Exponential Power
PM0301	Battery	Battery Charger AT-10		(Hindle)	Exponential Power
PM0301	Battery	Battery Charger ATEVO		(Hindle)	Exponential Power
	Battery	Battery Fiberglass Enclosure with A/C		(Exponential)	Exponential Power
PM0303	Battery	Battery Rack		(Energys)	Exponential Power
	Bolts	Bolts Anchor		Valmont, Threaded Fasteners	
	Bolts	Bolts Anchor cage for Substation Steel		Valmont, Threaded Fasteners (size limit)	
SD0203	Breaker	Breaker, EHV	345/500kV (Live Tank)	Hitachi Energy	
SD0203	Breaker	Breaker, EHV	345/500kV (Dead Tank)	(MEPPI), Hitachi Energy	MEPPI
SD0202	Breaker	Breaker, HV	69kv	(Siemens), MEPPI, Hitachi Energy	Siemens
SD0202	Breaker	Breaker, HV	115kV - 40kA	(Siemens), MEPPI, Hitachi Energy	Siemens
SD0202	Breaker	Breaker, HV	115kV - 63kA	(Siemens), MEPPI, Hitachi Energy	Siemens
SD0202	Breaker	Breaker, HV	161kV - 40kA	(Siemens), MEPPI, Hitachi Energy	Siemens
SD0202	Breaker	Breaker, HV	161kV - 63kA	(Siemens), MEPPI, Hitachi Energy	Siemens
SD0202	Breaker	Breaker, HV	245kV	(Siemens), MEPPI, Hitachi Energy	Siemens
SD0202	Breaker	Breaker, HV	245kV, 80kA	(Siemens), MEPPI, Hitachi Energy	Siemens
SD0201	Breaker	Breaker, MV	15 kV- 27kV	(ABB INC.) MEPPI	ABB Inc. Approval drawings 5 wks from issue date of po
SD0201	Breaker	Breaker, MV	34.5 kV	(ABB INC.)	ABB Inc. Approval drawings 5 wks from issue date of po
SB0101	Bus	Bus, Aluminum Pipe		(Three D Metals) AFL	Three D Metals
PB0401	Cable, Control	Control Cable -Shielded and Non-Shielded		(Southwire), Priority	Southwire
SA0303	Capacitor Bank	Capacitor Banks, Series		Cooper, Hitachi Energy	Cooper Approval drawings 4 wks from issue date of po
SA0301	Capacitor Bank	Capacitor Banks, Shunt		Cooper, GE, Hitachi Energy	Cooper Approval drawings 4 wks from issue date of po
	Capacitor Bank	Capacitor Cans	Capacitor Cans	Cooper, GE, Hitachi Energy	
	Capswitcher	Capswitcher	34.5kV and below	(Southern States)	Preferred Sales Approval drawings 4-6 wks from issue date of po
	Capswitcher	Capswitcher	245kV - 362kV	(Southern States)	Preferred Sales Approval drawings 4-6 wks from issue date of po
	Capswitcher	Capswitcher	115kV and above	(Southern States)	Preferred Sales Approval drawings 4-6 wks from issue date of po
	Capswitcher	Capswitcher	69KV	(Southern States)	Preferred Sales Approval drawings 4-6 wks from issue date of po
	Carrier	Power line Carrier	UPLC	Pulsar	Ametek
PN0201	CCVT	CCVT	69KV - 500kV	(Ritz), GE, Trench, Hitachi Energy	Aertker Approval drawings 2 wks from issue date of po

Lead Time					Date last updated: August 22, 2023
Purchase Spec.	Class	Description	Qualifier	Approved Manufacturer(s) ()-Preferred	Preferred Supplier
SD1801	Circuit Switcher	Circuit Switcher	Series 2000	(S&C)	Curtis Stout Approval drawings 3 wks from issue date of po
SD1802	Circuit Switcher	Circuit Switcher	Mark V	(S&C)	Curtis Stout Approval drawings 3 wks from issue date of po
	Conductor	Cable, Aluminum	ACSS, ACSR	(General Cable) - Southwire	Aertker co
	Conductor	Cable, Copper (Not Control cable)		Copperweld /Alcoa	Stuart Irby
	Conductor	Cable, Fiber	OPT-GW	AFL	Preferred Sales
	Conductor	Cable, Fiber	ADSS	AFL	Preferred Sales
	Conduit	Conduit & Accessories		Cantex, Carlon	Stuart Irby
	Connector	Connectors line	ACSS	AFL	Preferred Sales
	Connector	Connectors line (Fiber, OPGW, ACSR)	Fiber, OPGW, ACSR	AFL	Preferred Sales
	Connector	Connectors, Trans. Line - Insulator Assemblies		(Maclean Power Sys)	Preferred Sales
	Connectors/Fittings	Connectors/Fittings - Substation		Any Approved Manufacturer	Stuart Irby
SL0403	Control House	Control House	Drop-In (turnkey)	VFP	VFP
SL0403	Control House	Control House		(Modular Connections), AZZ Inc., Trachte, VFP	Modular Connections
PN0301	CT	CT	15kV - 34.5kV	ABB Inc, Ritz	
PN0301	CT	CT	69kv - 138kv	GE, Trench, Hitachi Energy, Ritz	
PN0301	CT	CT	161kV -230kV	GE, Trench, Hitachi Energy, Ritz	
PN0301	CT	CT	345kv - 500kV	GE, Trench, Hitachi Energy	
	CT	CT	Slipover only	ITEC, ABB Inc., Meramec	ITEC Approval drawings 2-3 wks from issue date of po
	DFR	DFR (Digital Fault Recorder)		MehtaTech	Louisiana, Mississippi, Arkansas only
	DFR	DFR (Digital Fault Recorder)		Qualitrol	Texas only
	Fittings	Conductor Fittings		AFL, Sefcor, Anderson, Hubell	Stuart Irby
	Grounds Rods Clamps	Ground Rods, Clamps, & Anodes		Any Approved Manufacturer	Stuart Irby
	Helical Piles	Foundation Piling		Hubbell, Cyntech	
TA0504	Insulators	Insulator, Line, Polymer		(Maclean Power Sys)	Preferred Sales
TA0504	Insulators	Insulator, Line, Polymer	(Polymer Insulator Only)	(Maclean Power Sys)	Preferred Sales
TA0504	Insulators	Insulator, Line, Polymer	(Polymer Insulator Assembly)	(Maclean Power Sys)	Preferred Sales
TA0504	Insulators	Insulator, Line, Polymer	Hardware Assembly Only	(Maclean Power Sys)	Preferred Sales

Appendix 2: High Voltage Overhead Transmission

Attachment 5: APPROVED VENDOR LIST

Date last updated: August 22, 2023

Purchase Spec.	Class	Description	Qualifier	Approved Manufacturer(s) ()-Preferred	Preferred Supplier
SA0502	Insulators	Insulator, Station Post, Porcelain	161kV (Porcelain)	(Hubbell), Victor, Lapp,NGK, Newell, Vanguard, Seves	Hubbell Power Systems
SA0502	Insulators	Insulator, Station Post, Porcelain	345/500kV (Porcelain) HI / EXTRA HIGH STRENGTH	Hubbell, Victor, Lapp,NGK, Newell, Vanguard, Seves	
SA0502	Insulators	Insulator, Station Post, Porcelain	230kV (Porcelain) STANDARD STRENGTH	(Hubbell), Victor, Lapp,NGK, Newell, Vanguard, Seves	Hubbell Power Systems
SA0502	Insulators	Insulator, Station Post, Porcelain	69kV, 115kV, (Porcelain)	(Hubbell), Victor, Lapp,NGK, Newell, Vanguard, Seves	Hubbell Power Systems
SA0502	Insulators	Insulator, Station Post, Porcelain	230kV (Porcelain) HI / EXTRA HIGH STRENGTH	Hubbell, Victor, Lapp,NGK, Newell, Vanguard, Seves	
	Insulators	Insulator, Station Post, Porcelain	34.5kV and below (Porcelain)	(Vanguard), Victor, Lapp,NGK, Newell, Seves , Hubbell	Preferred Sales
SA0502	Insulators	Insulator, Station Post, Polymer	15kV - 230kV	(Maclean Power Sys)	Preferred Sales
	Interrupter	Interrupter, Joslyn		Joslyn	Ruffin
	Interrupter	Switches LLS I		(Southern States)	Preferred Sales
	Interrupter	Switches LLS II		(Southern States)	Preferred Sales
	Interrupter	Whip		(Southern States)	Preferred Sales
	Interrupter	Interrupter		S&C	Curtis Stout
	Junction Box	Junction Boxes		MMR, Premier Control, SEL	All Junction Boxes – (2) weeks before Entergy's delivery date as stated on the PO
	Panel	Panel - Battery Switching		MMR, SEL, Premier Control	(4) weeks before Entergy's delivery date as stated on the PO.
	Panel	Panel - Communication rack		MMR, SEL, Premier Control	(3) weeks before Entergy's delivery date as stated on the PO.
PM0101	Panel	Panel - AC & DC Cabinets		MMR, SEL, Premier Control, Peterson Panel	(4) weeks before Entergy's delivery date as stated on the PO.
	Panel	Panel - Breaker Line		MMR, SEL, Premier Control	(4) weeks before Entergy's delivery date as stated on the PO.
PM0602	Panel	Panel - Bus Differential		MMR, SEL, Premier Control	Bus Diff/FMR Diff Breaker Control/ACDC Breaker – (3) weeks before Entergy's delivery date as stated on the PO.
PM1803	Panel	Panel - Line Protection		MMR, SEL, Premier Control	(4) weeks before Entergy's delivery date as stated on the PO.
	Panel	Panel - Meter		MMR, SEL, Premier Control	(4) weeks before Entergy's delivery date as stated on the PO.

Date last updated: August 22, 2023

Purchase Spec.	Class	Description	Qualifier	Approved Manufacturer(s) ()-Preferred	Preferred Supplier
TC0609	Poles	Pole Caissons	T-Line - after approval	(Valmont)	Preferred Sales
	Poles	Pole, Concrete		(Valmont)	Preferred Sales
TC0608	Poles	Pole, Steel	after approval	Valmont)	Preferred Sales
PN0701	PT	PT	15kV - 34.5kV	ABB Inc, GE, Ritz	
PN0701	PT	PT	69kv - 230kv	Hitachi Energy, GE, Trench	
SN0903	Reactor	Reactor, Dry Type Shunt	Below 230kV	Hitachi Energy, Coil Innovations, Trench	
SN0902	Reactor	Reactor, Limiting		Hitachi Energy, Coil Innovations, Trench	
SN0904	Reactor	Reactor, Oil filled Shunt	230kV, 500kV	Hitachi Energy, Prolec GE, MEPPi, Siemens, SMIT	
SN1002	Regulators	Regulator		Pennsylvania Transformers	Curtis Stout
	Relay	SEL Relays	SEL Relay	SEL	Power Connection
	Relay	SEL cables	Cable & Fiber	SEL	Power Connection
	RTU	ACS RTU - Peripherals	NTX-U20 & Upgrades	ACS (Automated Control Systems)	Ruffin & Associates
	RTU	ACS Cables	NTX cables	ACS (Automated Control Systems)	Ruffin & Associates
	RTU	GE Parts	Accessories & Cables	G.E. Grid Solutions	Preferred Sales
PM3002	RTU	RTU	IO cabinet standard RTU	G.E. Grid Solutions	Preferred Sales
PM3002	RTU	RTU - Kits & Parts	D400, D20, DNPIO Kits & Parts	G.E. Grid Solutions	Preferred Sales
	Rupter	Rupters/S&C ALDUTI 15 kV Vac		(S&C)	Curtis Stout Approval drawings 5 wks from issue date of po
SL1301	Signs	Signs - Entergy Substation Switchyard		Impco	Impco
	Signs	Signs - General		Stuart Irby	Stuart Irby

Appendix 2: High Voltage Overhead Transmission

Attachment 5: APPROVED VENDOR LIST

revised OCT 2023

TWO-WINDING & AUTO-TRANSFORMERS RATED < 100MVA (3-phase) and HV ≤ 230kV

Production Facility & Location	Currently qualifying or already qualified	Maximum ratings approved by Entergy		Capabilities reported by facility	
		MVA (3ø)	KV	MVA (3ø)	KV
ABB / Crystal Springs, MS USA	qualified	50 (MS)	161 (MS)	~60 (MS)	161 (MS)
Delta Star / Lynchburg, VA	qualified	100	230	~200	230
Waukesha Electric (SPX), Goldsboro, NC & Waukesha, WI USA	qualified	80 (NC), 100 (WI)	230 (NC), 230 (WI)	~80 (NC), 800 (WI)	230 (NC), 345 (WI)

AUTO-TRANSFORMERS RATED ≥ 100MVA (3-phase) or HV > 230kV

Production Facility & Location	Currently qualifying or already qualified	Maximum ratings approved by Entergy		Capabilities reported by facility	
		MVA (3ø)	KV	MVA (3ø)	KV
ABB / Varennes, Quebec, Canada; Guarulhos, Brazil; Cordoba, Spain	qualified	1000 (Can), 500 (Br), 800 (Sp)	500 (Can), 500 (Br), 500 (Sp)	1200 (Can), 600 (Br), 800 (Sp)	765 (Can), 765 (Br), 500 (Sp)
Mitsubishi / Ako, Japan	qualified	~1000	500	~1500	1000+
Siemens / Linz & Weiz, Austria; Nuremburg, Germany; Jundiai, Brazil; Bogota, Colombia	qualified	1000 (Aus, Ger), 800 (Br), 200 (Col)	500 (Aus, Ger, Br), 230 (Col)	2000 (Aus), 1100 (Ger), 1000 (Br), 250 (Col)	765 (Aus), 1000+ (Ger), 765 (Br), 345 (Col)
SMIT / Nijmegen, Netherlands	qualified	~800	500	~1200	765
Waukesha Electric (SPX), Waukesha, WI USA	qualified	~600	345	~800	345

Appendix 2: High Voltage Overhead Transmission

ATTACHMENT 6: ENTERGY LOADING DISTRICTS

State	County	Extreme Wind mph	NESC District			Extreme Ice inches	Entergy Load Case
			Light	Medium	Heavy		
AR	Arkansas	100		M		1	LC-2
AR	Ashley	100		M		1	LC-2
AR	Baxter	100			H	1	LC-1
AR	Benton	100			H	1	LC-1
AR	Boone	100			H	1	LC-1
AR	Bradley	100		M		1	LC-2
AR	Calhoun	100		M		1	LC-2
AR	Carroll	100			H	1	LC-1
AR	Chicot	100		M		1	LC-2
AR	Clark	100			H	1	LC-1
AR	Clay	100			H	1	LC-1
AR	Cleburne	100			H	1	LC-1
AR	Cleveland	100		M		1	LC-2
AR	Columbia	100		M		1	LC-2
AR	Conway	100			H	1	LC-1
AR	Craighead	100		M		1	LC-2
AR	Crawford	100			H	1	LC-1
AR	Crittenden	100		M		1	LC-2
AR	Cross	100		M		1	LC-2
AR	Dallas	100		M		1	LC-2
AR	Desha	100		M		1	LC-2
AR	Drew	100		M		1	LC-2
AR	Faulkner	100			H	1	LC-1
AR	Franklin	100			H	1	LC-1
AR	Fulton	100			H	1	LC-1
AR	Garland	100			H	1	LC-1
AR	Grant	100		M		1	LC-2
AR	Greene	100			H	1	LC-1
AR	Hempstead	100			H	1	LC-1
AR	Hot Spring	100			H	1	LC-1
AR	Howard	100			H	1	LC-1
AR	Independence	100			H	1	LC-1
AR	Izard	100			H	1	LC-1
AR	Jackson	100			H	1	LC-1
AR	Jefferson	100		M		1	LC-2

Appendix 2: High Voltage Overhead Transmission

ATTACHMENT 6: ENTERGY LOADING DISTRICTS

State	County	Extreme Wind mph	NESC District			Extreme Ice inches	Entergy Load Case
			Light	Medium	Heavy		
AR	Johnson	100			H	1	LC-1
AR	Lafayette	100		M		1	LC-2
AR	Lawrence	100			H	1	LC-1
AR	Lee	100		M		1	LC-2
AR	Lincoln	100		M		1	LC-2
AR	Little River	100			H	1	LC-1
AR	Logan	100			H	1	LC-1
AR	Lonoke	100		M		1	LC-2
AR	Madison	100			H	1	LC-1
AR	Marion	100			H	1	LC-1
AR	Miller	100		M		1	LC-2
AR	Mississippi	100		M		1	LC-2
AR	Monroe	100		M		1	LC-2
AR	Montgomery	100			H	1	LC-1
AR	Nevada	100		M		1	LC-2
AR	Newton	100			H	1	LC-1
AR	Ouachita	100		M		1	LC-2
AR	Perry	100			H	1	LC-1
AR	Phillips	100		M		1	LC-2
AR	Pike	100			H	1	LC-1
AR	Poinsett	100		M		1	LC-2
AR	Polk	100			H	1	LC-1
AR	Pope	100			H	1	LC-1
AR	Prairie	100		M		1	LC-2
AR	Pulaski	100			H	1	LC-1
AR	Randolph	100			H	1	LC-1
AR	St. Francis	100		M		1	LC-2
AR	Saline	100			H	1	LC-1
AR	Scott	100			H	1	LC-1
AR	Searcy	100			H	1	LC-1
AR	Sebastian	100			H	1	LC-1
AR	Sevier	100			H	1	LC-1
AR	Sharp	100			H	1	LC-1
AR	Stone	100			H	1	LC-1
AR	Union	100		M		1	LC-2
AR	Van Buren	100			H	1	LC-1
AR	Washington	100			H	1	LC-1
AR	White	100			H	1	LC-1
AR	Woodruff	100		M		1	LC-2
AR	Yell	100			H	1	LC-1
MO	Dunklin	100			H	1	LC-1
MO	New Madrid	100			H	1	LC-1
MO	Oregon	100			H	1	LC-1
MO	Pemiscot	100			H	1	LC-1
MO	Stoddard	100			H	1	LC-1
MO	Taney	100			H	1	LC-1

Appendix 2: High Voltage Overhead Transmission

ATTACHMENT 6: ENTERGY LOADING DISTRICTS

State	Parish	Extreme Wind mph	NESC District			Extreme Ice inches	Entergy Load Case
			Light	Medium	Heavy		
LA	Acadia	150	L			0.5	LC-3D
LA	Allen	125	L			0.5	LC-3B
LA	Ascension	150	L			0.5	LC-3D
LA	Assumption	150	L			0.5	LC-3D
LA	Avoyelles	110	L			0.5	LC-3F
LA	Beauregard	125	L			0.5	LC-3B
LA	Bienville	100		M		0.75	LC-2D
LA	Bossier	100		M		0.75	LC-2D
LA	Calcasieu	150	L			0.5	LC-3D
LA	Caldwell	100		M		0.75	LC-2D
LA	Cameron	150	L			0.5	LC-3D
LA	Catahoula	100	L			0.5	LC-3E
LA	Claiborne	100		M		0.75	LC-2D
LA	Concordia	100	L			0.5	LC-3E
LA	Desoto	100		M		0.75	LC-2D
LA	East Baton Rouge	150	L			0.5	LC-3D
LA	East Carrol	100		M		0.75	LC-2D
LA	East Feliciana	125	L			0.5	LC-3B
LA	Evangeline	125	L			0.5	LC-3B
LA	Franklin	100		M		0.75	LC-2D
LA	Grant	100	L			0.75	LC-2C
LA	Iberia	150	L			0.5	LC-3D
LA	Iberville	150	L			0.5	LC-3D
LA	Jackson	100		M		0.75	LC-2D
LA	Jefferson	150	L			0.5	LC-3D
LA	Jefferson Davis	150	L			0.5	LC-3D
LA	Lafayette	150	L			0.5	LC-3D
LA	Lafourche	150	L			0.5	LC-3D
LA	Lasalle	100	L			0.75	LC-3C
LA	Lincoln	100		M		0.75	LC-2D
LA	Livingston	150	L			0.5	LC-3D
LA	Madison	100	L			0.75	LC-3C
LA	Morehouse	100		M		0.75	LC-2D
LA	Natchitoches	100		M		0.75	LC-2D
LA	Orleans	150	L			0.5	LC-3D
LA	Ouachita	100		M		0.75	LC-2D
LA	Plaquemines	150	L			0.5	LC-3D
LA	Point Coupee	125	L			0.5	LC-3B
LA	Rapides	100	L			0.5	LC-3E
LA	Red River	100		M		0.75	LC-2D
LA	Richland	100		M		0.75	LC-2D
LA	Sabine	100		M		0.75	LC-2D
LA	St. Bernard	150	L			0.5	LC-3D
LA	St. Charles	150	L			0.5	LC-3D

Appendix 2: High Voltage Overhead Transmission

ATTACHMENT 6: ENTERGY LOADING DISTRICTS

State	Parish	Extreme Wind mph	NESC District			Extreme Ice inches	Entergy Load Case
			Light	Medium	Heavy		
LA	St. Helena	125	L			0.5	LC-3B
LA	St. James	150	L			0.5	LC-3D
LA	St. John the Baptist	150	L			0.5	LC-3D
LA	St. Landry	125	L			0.5	LC-3B
LA	St. Martin, North	150	L			0.5	LC-3D
LA	St. Martin, South	150	L			0.5	LC-3D
LA	St. Mary	150	L			0.5	LC-3D
LA	St. Tammany	150	L			0.5	LC-3D
LA	Tangipahoa	150	L			0.5	LC-3D
LA	Tensas	100	L			0.5	LC-3E
LA	Terrebonne	150	L			0.5	LC-3D
LA	Union	100		M		0.75	LC-2D
LA	Vermillion	150	L			0.5	LC-3D
LA	Vernon	100	L			0.5	LC-3E
LA	Washington	125	L			0.5	LC-3B
LA	Webster	100		M		0.75	LC-2D
LA	West Baton Rouge	150	L			0.5	LC-3D
LA	West Carrol	100		M		0.75	LC-2D
LA	West Feliciana	125	L			0.5	LC-3B
LA	Winn	100		M		0.75	LC-2D

Appendix 2: High Voltage Overhead Transmission

ATTACHMENT 6: ENTERGY LOADING DISTRICTS

State	County	Extreme Wind mph	NESC District			Extreme Ice inches	Entergy Load Case
			Light	Medium	Heavy		
MS	Adams	100	L			0.5	LC-3E
MS	Amite	110	L			0.5	LC-3F
MS	Attala	100	L			0.5	LC-3E
MS	Benton	100		M		1	LC-2
MS	Bolivar	100		M		1	LC-2
MS	Calhoun	100		M		1	LC-2
MS	Carroll	100		M		1	LC-2
MS	Chickasaw	100		M		1	LC-2
MS	Choctaw	100		M		1	LC-2
MS	Claiborne	100	L			0.5	LC-3E
MS	Clay	100		M		1	LC-2
MS	Coahoma	100		M		1	LC-2
MS	Copiah	100	L			0.5	LC-3E
MS	Covington	110	L			0.5	LC-3F
MS	Desoto	100		M		1	LC-2
MS	Franklin	100	L			0.5	LC-3E
MS	Grenada	100		M		1	LC-2
MS	Hinds	100	L			0.5	LC-3E
MS	Holmes	100		M		1	LC-2
MS	Humphreys	100		M		1	LC-2
MS	Issaquena	100	L			1	LC-3G
MS	Jefferson	100	L			0.5	LC-3E
MS	Jefferson Davis	110	L			0.5	LC-3F
MS	Lafayette	100		M		1	LC-2
MS	Lawrence	110	L			0.5	LC-3F
MS	Leake	100	L			0.5	LC-3E
MS	Leflore	100		M		1	LC-2
MS	Lincoln	110	L			0.5	LC-3F
MS	Madison	100	L			0.5	LC-3E
MS	Marion	110	L			0.5	LC-3F
MS	Marshall	100		M		1	LC-2
MS	Montgomery	100		M		1	LC-2
MS	Neshoba	100	L			0.5	LC-3E
MS	Newton	100	L			0.5	LC-3E
MS	Panola	100		M		1	LC-2
MS	Pike	110	L			0.5	LC-3F
MS	Ponotoc	100		M		1	LC-2
MS	Quitman	100		M		1	LC-2
MS	Rankin	100	L			0.5	LC-3E
MS	Scott	100	L			0.5	LC-3E
MS	Sharkey	100	L			0.75	LC-3C
MS	Simpson	100	L			0.5	LC-3E
MS	Smith	110	L			0.5	LC-3F

Appendix 2: High Voltage Overhead Transmission

ATTACHMENT 6: ENTERGY LOADING DISTRICTS

State	County	Extreme Wind mph	NESC District			Extreme Ice inches	Entergy Load Case
			Light	Medium	Heavy		
MS	Sunflower	100		M		1	LC-2
MS	Tallahatchie	100		M		1	LC-2
MS	Tate	100		M		1	LC-2
MS	Tippah	100		M		1	LC-2
MS	Tunica	100		M		1	LC-2
MS	Union	100		M		1	LC-2
MS	Walthall	110	L			0.5	LC-3F
MS	Warren	100	L			0.5	LC-3E
MS	Washington	100		M		1	LC-2
MS	Webster	100		M		1	LC-2
MS	Wilkinson	110	L			0.5	LC-3F
MS	Winston	100	L			0.5	LC-3E
MS	Yalobusha	100		M		1	LC-2
MS	Yazoo	100	L			0.75	LC-3C

Appendix 2: High Voltage Overhead Transmission

ATTACHMENT 6: ENTERGY LOADING DISTRICTS

State	County	Extreme Wind mph	NESC District			Extreme Ice inches	Entergy Load Case
			Light	Medium	Heavy		
TX	Angelina	100		M		0.75	LC-2D
TX	Brazos	100		M		0.75	LC-2D
TX	Burleson	100		M		0.5	LC-2B
TX	Chambers	150	L			0.5	LC-3D
TX	Galveston	150	L			0.5	LC-3D
TX	Grimes	100		M		0.75	LC-2D
TX	Hardin	125	L			0.5	LC-3B
TX	Harris	125	L			0.5	LC-3B
TX	Houston	100		M		0.75	LC-2D
TX	Jasper	125		M		0.5	LC-2C
TX	Jefferson	150	L			0.5	LC-3D
TX	Leon	100		M		0.75	LC-2D
TX	Liberty	125	L			0.5	LC-3B
TX	Limestone	100		M		0.75	LC-2D
TX	Madison	100		M		0.75	LC-2D
TX	Montgomery	110		M		0.5	LC-2A
TX	Nacogdoches	100		M		0.75	LC-2D
TX	Newton	125		M		0.5	LC-2C
TX	Orange	150	L			0.5	LC-3D
TX	Polk	110		M		0.75	LC-2E
TX	Robertson	100		M		0.75	LC-2D
TX	Sabine	100		M		0.75	LC-2D
TX	San Augustine	100		M		0.75	LC-2D
TX	San Jacinto	100		M		0.75	LC-2D
TX	Trinity	100		M		0.75	LC-2D
TX	Tyler	110		M		0.75	LC-2E
TX	Walker	100		M		0.75	LC-2D
TX	Waller	110	L			0.5	LC-3F
TX	Washington	100	L			0.5	LC-3E

Appendix 2: High Voltage Overhead Transmission

ATTACHMENT 6: ENTERGY LOADING DISTRICTS

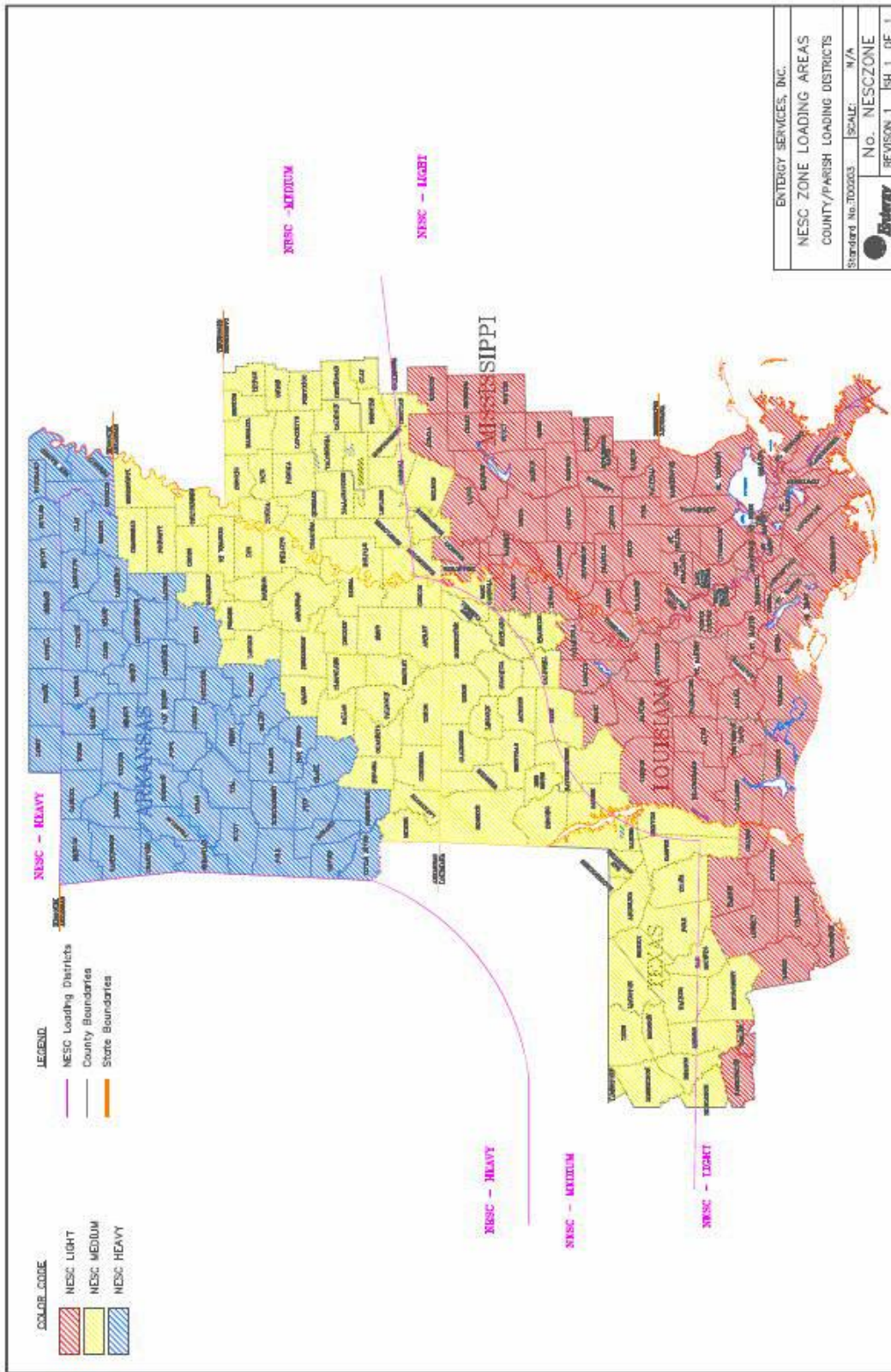

Appendix 2: High Voltage Overhead Transmission

ATTACHMENT 6: ENTERGY LOADING DISTRICTS

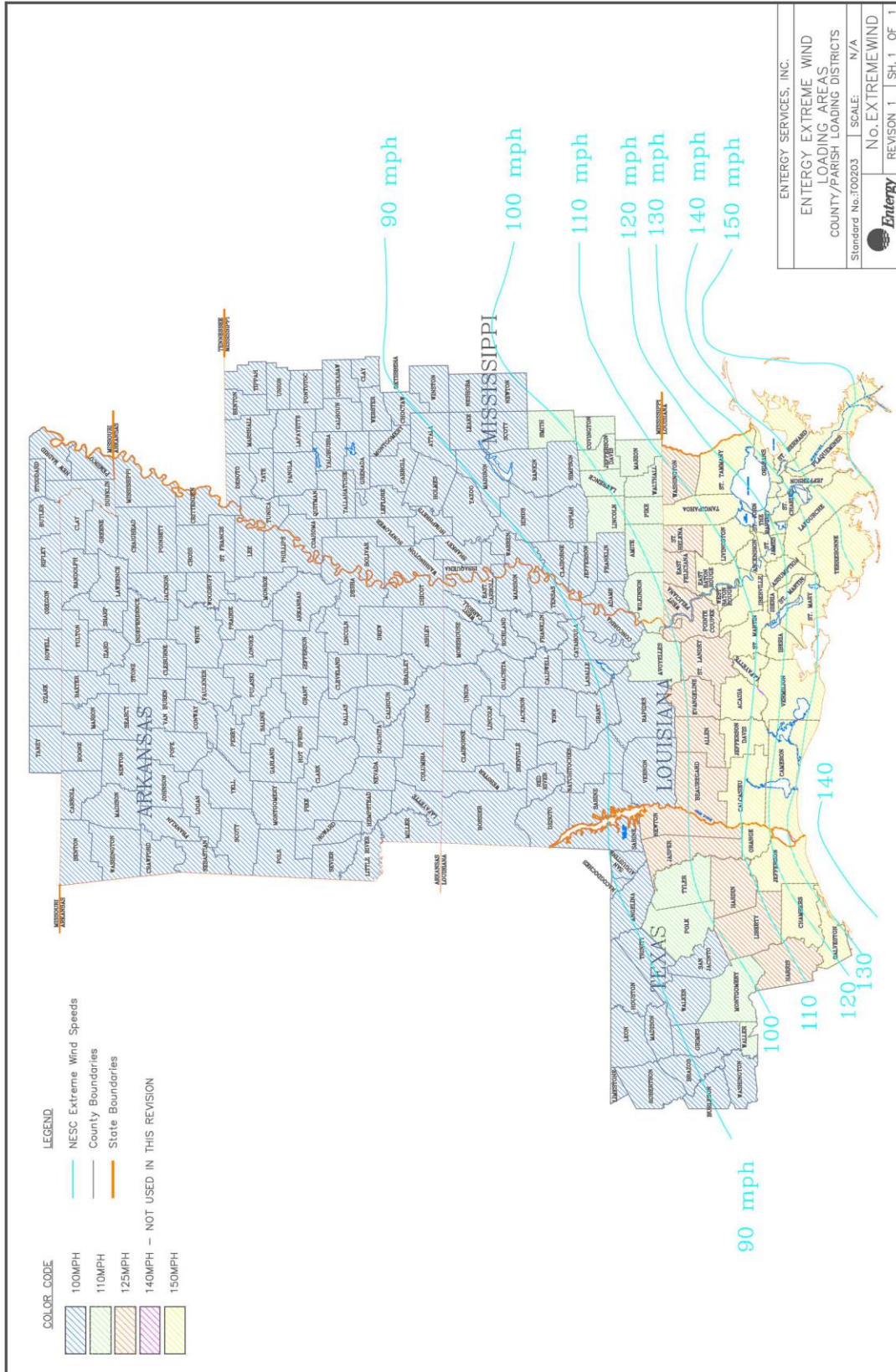

Appendix 2: High Voltage Overhead Transmission

ATTACHMENT 6: ENTERGY LOADING DISTRICTS

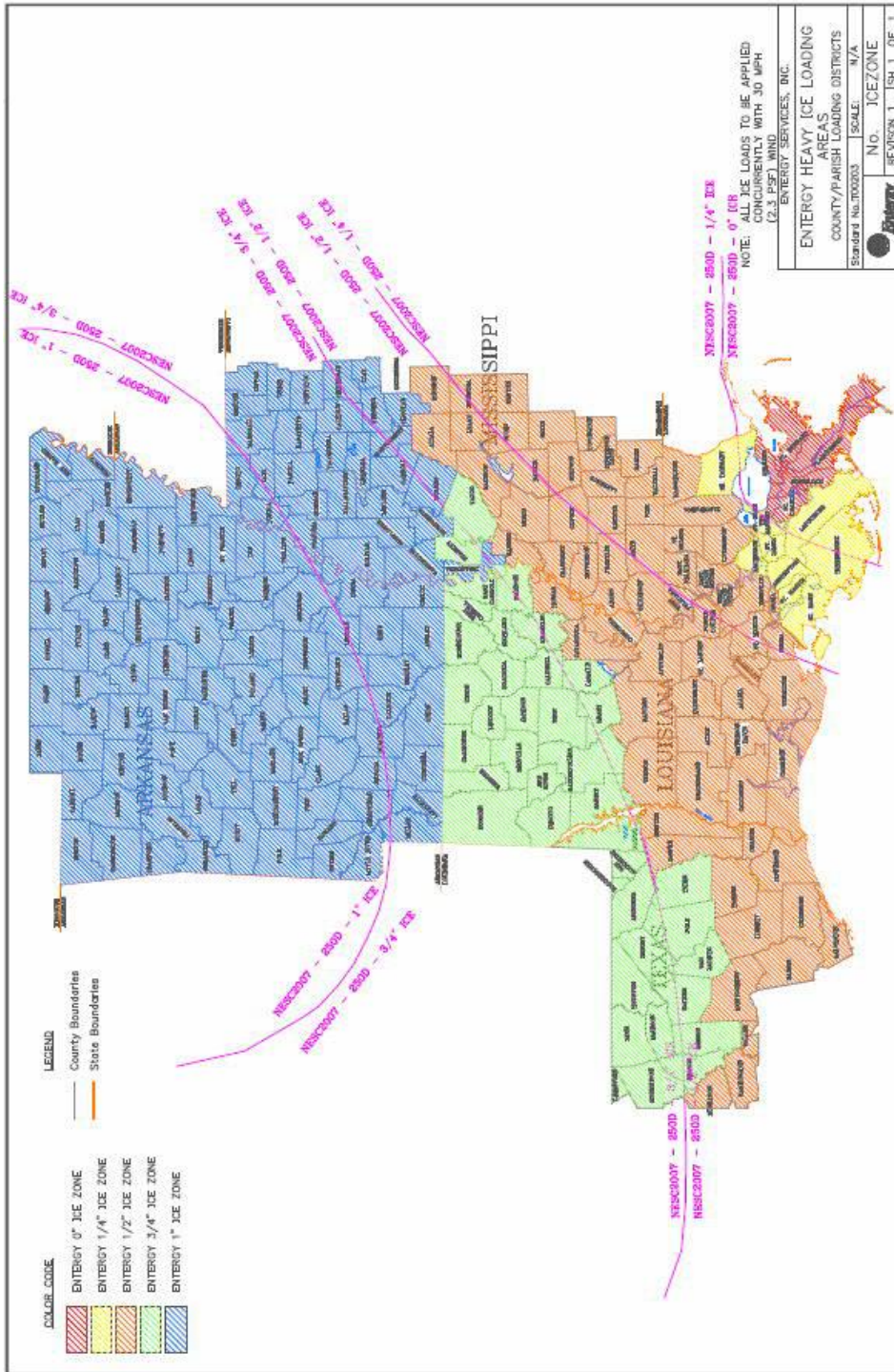

Appendix 2: High Voltage Overhead Transmission

ATTACHMENT 6: ENERGY LOADING DISTRICTS

***** END OF APPENDIX 2*****



Solar BOT Scope Book

Appendix 3

Performance Guarantees

REVISION RECORD			
Revision No.	Approval Date	Section / Page Revised	Reason / Description of Change
0	9/14/2023	All	Initial Issue
25-1	5/19/2025	All	Editorial corrections
26-1	3/3/2026	All	Editorial corrections

Appendix 3: Performance Guarantees

Nº	CHARACTERISTICS	UNITS	DATA	NOTES
1	MINIMUM CRITERIA			
1.1	Guaranteed PV Plant Capacity (@ Electrical Interconnection Point (EIP))	MW _{ac}		Final
1.2	Minimum PV Plant Capacity (@Electrical Interconnection Point (EIP))	MW _{ac}		Final 95% of Guaranteed PV Plant Capacity
1.3	Guaranteed Run Requirement	Duration		Uninterrupted operation during the Project Performance Test for PV Plant Capacity subject to the Failure Mode Guidelines as set forth in Appendix 7 of this Scope Book
1.4	Project Net Electricity Production (P50) in Year 1 (starting at the Substantial Completion Payment Date) @ Electrical Interconnection Point (EIP))	MWh		Final

Notes:

“Final” – Seller may update data or other information for the specified characteristic only with the prior written agreement of Buyer and Seller, which shall not be unreasonably withheld by either Party.

This Appendix is subject to, without limitation, the terms of the Scope Book.



Solar BOT Scope Book

Appendix 4

Energy Model

REVISION RECORD			
Revision No.	Approval Date	Section / Page Revised	Reason / Description of Change
0	9/14/2023	All	Initial Issue
25-1	5/19/2025	All	Editorial corrections
26-1	3/3/2026	All	Editorial corrections

Appendix 4: Energy Model

The following table will be used to establish Seller’s bid basis in regard to the PV Plant performance and estimated annual Energy Yield. Seller shall complete all of the information requested in the below table in order to establish said basis of their bid. These Energy Yield model inputs, once agreed to and finalized as part of the Agreement will form the basis of the Appendix 7 – Performance Test Plant Capacity Model inputs, except as modified in Appendix 7 to account for adjusted system losses which are applicable at the time of the test vs. the assumed annual Energy Yield, such as soiling losses and module degradation / Light Induced Degradation (**LID**).

Once Seller and Buyer agree to the inputs, any Seller change in the inputs that may decrease performance must be approved by Buyer.

Refer to examples in Table 1 below for guidance on various testing scenarios:

Table 1: Energy Model Examples

Input	Annual Energy Yield Estimate Model	Plant Capacity Model
Soiling Rates	Include reasonable/agreed to monthly soiling profile estimates for the year.	Soiling stations’ measurements are averaged during test period and then entered into all of the monthly averages for the model.
LID	Year-1 guaranteed module losses less the Year 2 – 30 annual degradation (Year-1 = 2.00% / 0.45% Annual, so modeled LID would be 2.00 – 0.45 = 1.55%)	Module manufacturer guidance for LID test data may be used. This can be adjusted down from the guaranteed rate, to remove the margin included in the OEM warranty rates. 50% of the LID warranty rate or 1.0% have been accepted values in the past. Annual Degradation is then added to this value as the average installed life of the modules on the site. e.g., average installed duration for the modules is 6 months, add on 0.45% * 6/12 = 0.225%, overall LID = 1.225%
Annual Degradation	OEM Guaranteed Rate (e.g. 0.45%)	0.00% (included in LID)
Module Quality	If flash test data is not available, 25% of the positive bin tolerance. e.g., 625W module +5/-0 bin tolerance. 5/625 = .008 = 0.8%, so take 25% of that and it gives you a -0.2% module quality model input value.	Actual average positive binning tolerance based on flash test results. So if average flash test for all modules was +2.5W then you would use 2.5/625 = .004 = 0.4% or a -0.4% modeling input for the capacity test.

Appendix 4: Energy Model

		CERTAIN ENERGY MODEL INPUTS			
Nº	CHARACTERISTICS	UNITS	DATA		NOTES
1	REFERENCE SITE CONDITIONS	-	Bid Basis – Annual Energy Yield Estimate	Performance Test Plant Capacity Model	
1.1	Annual Global Horizontal Insolation (GHI) @ ground level	kWh/m ² /year			
1.2	Annual Diffuse Horizontal Insolation (DHI) @ ground level	kWh/m ² /year			
1.3	Altitude (above sea level)	ft			
2	WEATHER DATA	-			
2.1	Data source	-			
2.2	Period of data collection	months			
2.3	Distance from site or spatial resolution	km			
2.4	Uncertainty	%			
3	MODEL PARAMETERS	-			
3.1	Installed Capacity (DC)	MWp			
3.2	Nominal Power (AC)	MW			
3.3	Nominal Power at Electrical POI (AC)	MW			
3.4	DC/AC ratio	-			
3.5	PVsyst Software Version (should be as bid)	-			
3.6	Transposition Model	-			
3.7	Meteorological File Parameters (should be as bid)	-			Interval end is preferred
3.8	Post Processed Losses	%			
3.9	PV Modules	-			
3.9.1	PV module manufacturer and model	-			
3.9.2	PV module power at STC	Wp			
3.9.3	Technology	-			
3.9.4	Number of PV Modules per string	-			

Appendix 4: Energy Model

		CERTAIN ENERGY MODEL INPUTS			
Nº	CHARACTERISTICS	UNITS	DATA		NOTES
3.9.5	Total number of PV Modules installed	-			
3.9.6	Total number of strings	-			
3.10	Inverters	-			
3.10.1	Inverter manufacturer and model	-			
3.10.2	Input voltage rating	V_{dc}			
3.10.3	Number of strings per inverter	-			
3.10.4	Number of inverters	-			
3.11	Mounting System	-			
3.11.1	Tilt angle of rotation limits of tracking system	°			
3.11.2	Backtracking	Yes / No			
3.11.3	Orientation of PV Modules (azimuth)	°			
3.11.4	Installation type (portrait / landscape)	-			
3.11.5	Rows and columns per mounting structure	- x -			
3.11.6	Ground Coverage Ratio	%			
3.12	Array losses	-			
3.12.1	Module quality loss	%			See example in Table 1
3.12.2	Module mismatch losses	%			
3.12.3	String mismatch losses	%			
3.12.4	Light induced degradation losses	%			Refer to example in Table 1
3.12.5	IAM losses defined by manufacturer	Yes / No			
3.12.6	Constant thermal loss factor	$W/m^2/k$			
3.12.7	Wind loss factor	$W/m^2/k/$ m/s			

Appendix 4: Energy Model

		CERTAIN ENERGY MODEL INPUTS			
Nº	CHARACTERISTICS	UNITS	DATA		NOTES
3.12.8	Soiling losses January February March April May June July August September October November December	%			Refer to example in Table 1
3.12.9	Ground Albedo January February March April May June July August September October November December				Average Annual and Monthly
3.12.10	Spectral correction applied	Yes / No			
3.13	Cabling	-			
3.13.1	DC ohmic losses @STC (Max/Calculated)	%			
3.13.2	AC ohmic losses @STC (Max/Calculated)	%			
3.14	Transformers	-			
3.14.1	Transformer type	-			
3.14.2	Number of transformers	-			
3.14.3	Constant Loss	W			
3.14.4	Peak Power Loss	W			
3.15	System losses	-			

Appendix 4: Energy Model

		CERTAIN ENERGY MODEL INPUTS			
Nº	CHARACTERISTICS	UNITS	DATA		NOTES
3.15.1	Year 1 (starting at the Substantial Completion Payment Date) degradation	%			
3.15.2	Annual degradation	%			Refer to example in Table 1
3.15.3	Light soaking effect	%			
3.15.4	Inverter losses	%			
3.15.5	Auxiliary losses	%			
3.15.6	Unavailability	%			
3.15.7	Combined Uncertainty	%			
4	ANNUAL PERFORMANCE RESULTS	-	PVsyst Results	Final Results	Final Results include all post-processing work (assume 0% unavailability for model)
4.1	Net electricity production (P50)	MWh/yr			
4.1.3	30-year average, P50	MWh/yr			
4.2	Specific Yield (Year 1, starting at the Substantial Completion Date, P50)	kWh/kWp/yr			
4.3	Performance Ratio (Year 1, starting at the Substantial Completion Date, P50)	%			



Solar BOT Scope Book

Appendix 5

Design Basis and Operational Data

REVISION RECORD			
Revision No.	Approval Date	Section / Page Revised	Reason / Description of Change
25-1	5/19/2025	All	Original Publication
25-2	11/3/2025	All	General Updates

Appendix 5: Design Basis and Operational Data

1 Introduction

The tables within this appendix establish design and operational requirements for the Project. Seller shall populate tables with Project data. Once Seller and Buyer agree to the inputs, any change must be approved by Buyer.

Table 1: Design Conditions

1	DESIGN CONDITIONS	UNITS	DATA	COMMENTS / CLARIFICATIONS
1.1	Project Location	-		City, State (County/Parish)
1.2	Project Coordinates	°		Latitude/Longitude
1.3	Main Access Road	-		
1.4	Governing Building Code	-		
1.5	Design life of theProject	years		30 years minimum
1.6	Average site elevation	ft		Above Sea Level
1.7	Maximum Ambient Temperature Recorded	°F		
1.8	Minimum Ambient Temperature Recorded	°F		
1.9	Average High Temperature	°F		
1.10	Average Low Temperature	°F		
1.11	Maximum Design Temperature for Operation	°F		As defined in Section 1.2.1 of Scope Book.
1.12	Minimum Design Temperature for Operation	°F		As defined in Section 1.2.1 of Scope Book.
1.13	Maximum Design Humidity Ratio	%		grams of water vapor / grams of dry air
1.14	Minimum Design Humidity Ratio	%		grams of water vapor / grams of dry air
1.15	ASCE 7 Risk Category	-		Per IBC and ASCE 7
1.16	Wind Speed (Normal Position)	PH		Design per IBC and ASCE 7
1.17	Design Wind Speed (Stowed Position)	MPH		Design per IBC and ASCE 7
1.18	Annual Average Rainfall	inch		
1.19	Annual Maximum Rainfall	inch		

Solar BOT Scope Book: Appendix 5 Design Basis and Operational Data

Appendix 5: Design Basis and Operational Data

1	DESIGN CONDITIONS	UNITS	DATA	COMMENTS / CLARIFICATIONS
1.20	1-day Maximum Rainfall	inch		
1.21	Design Basis Rainfall Event	inch		
1.22	Maximum 500-year flood elevation	ft		Above Sea Level
1.23	Maximum flood elevation without equipment damage	ft		Above Sea Level
1.24	Global Horizontal Irradiance Typical Meteorological Year (TMY)	kWh/m ²		
1.25	Allowable Seismic Ground Accelerations, Short Period Shaking (S _s)	g		Ground acceleration values shall be confirmed by the Project's geotechnical study
1.26	Allowable Seismic Ground Accelerations, Long Period Shaking (S ₁)	g		Ground acceleration values shall be confirmed by the Project's geotechnical study
1.27	Available Area required (approximate)	acres		
1.28	Design Snow Load normal operation	$\frac{lb.}{ft.^2}$		Design per IBC and ASCE 7
1.29	Design Snow Load Stow position	$\frac{lb.}{ft.^2}$		Design per IBC and ASCE 7
1.30	Ice thickness normal operation / storm safe position			Design per IBC and ASCE 7
1.31	Ice thickness storm safe position	inch		Design per IBC and ASCE 7
1.32	Design vegetation height	inches		The lesser of the two values Referenced ASTM-E2908
1.33	Responding Fire department	-		Address and contact number
1.34	Responding Fire department distance	Miles		
1.35	Nearest water point or draft location used by fire department for this location	-		Address or GPS coordinates
1.36	Distance to nearest water point or draft location used by fire department for this location.	Miles		

Appendix 5: Design Basis and Operational Data

1	DESIGN CONDITIONS	UNITS	DATA	COMMENTS / CLARIFICATIONS
1.37	PV array fire mitigation strategy: non-combustible fire break via full perimeter roads and internal segregated by access roads.	Y/N		List deviations
1.38	Transformer fire mitigation: Confinement of oil and fire to transformer of origin per . Self-extinguishing oil impoundment.	Y/N		List deviations
1.39	Other physically occupiable structures: Noncombustible construction per IBC (international building code) edition adapted by state.	Y/N		List deviations
1.40	Adequate spatial separation to other exposures as needed to prevent secondary damage per NFPA-80a assume no fire department mitigation.	Y/N		List deviations

Appendix 5: Design Basis and Operational Data

Table 2: Performance Test Inputs

2	Test Term	UNITS	DATA	COMMENTS / CLARIFICATIONS
2.1	Guaranteed Availability	%		
2.2	Minimum Availability	%		

Table 3: General Plant Data

3	GENERAL PLANT DATA	UNITS	DATA	COMMENTS / CLARIFICATIONS
3.1	PV technology type			
3.2	Installed Capacity (DC)	MWp		total peak power
3.3	Nominal Power (AC)	MW		total nominal inverter output
3.4	Nominal Power (AC)	MW		At Electrical POI
3.5	DC/AC ratio			May not be modified after Agreement date without permission of both parties
3.6	Average Nighttime Auxiliary Power Average	MW		
3.7	Peak Nighttime Auxiliary Power	MW		
3.8	Annual Nighttime Auxiliary Power	MWh		Year 1 (starting at the Substantial Completion Payment Date) based on TMY
3.9	Total area covered by PV arrays	acres		
3.10	Total area of Project	acres		
3.11	Row to row spacing	ft		
3.12	Ground Coverage Ratio	%		
3.13	Shading losses due to internal row spacing	%		
3.14	Total number of PV panels	QTY		
3.15	Total number of strings	TY		
3.16	Total number of racking system tables	TY		
3.17	Total number of combiner boxes	TY		
3.18	Total number of inverters	TY		

Solar BOT Scope Book: Appendix 5 Design Basis and Operational Data

Appendix 5: Design Basis and Operational Data

3	GENERAL PLANT DATA	UNITS	DATA	COMMENTS / CLARIFICATIONS
3.19	Total number of LV/MV transformers	TY		

Table 4: Monthly Performance Ratios

4	MONTHLY PERFORMANCE RATIOS	UNITS	DATA	COMMENTS / CLARIFICATIONS
4.1	January	%		
4.2	February	%		
4.3	March	%		
4.4	April	%		
4.5	May	%		
4.6	June	%		
4.7	July	%		
4.8	August	%		
4.9	September	%		
4.10	October	%		
4.11	November	%		
4.12	December	%		
4.13	Performance Ratio Base	%		

Appendix 5: Design Basis and Operational Data

Table 5: Yearly Performance Ratios

5	YEARLY PERFORMANCE RATIOS	UNITS	DATA	COMMENTS / CLARIFICATIONS
5.1	Year 1	%		Starting at the Substantial Completion Payment Date
5.2	Year 2	%		
5.3	Year 3	%		
5.4	Year 4	%		
5.5	Year 5	%		
5.6	Year 6	%		
5.7	Year 7	%		
5.8	Year 8	%		
5.9	Year 9	%		
5.10	Year 10	%		
5.11	Year 11	%		
5.12	Year 12	%		
5.13	Year 13	%		
5.14	Year 14	%		
5.15	Year 15	%		
5.16	Year 16	%		
5.17	Year 17	%		
5.18	Year 18	%		
5.19	Year 19	%		
5.20	Year 20	%		
5.21	Year 21	%		
5.22	Year 22	%		
5.23	Year 23	%		
5.24	Year 24	%		
5.25	Year 25	%		
5.26	Year 26	%		
5.27	Year 27	%		
5.28	Year 28	%		
5.29	Year 29	%		

Appendix 5: Design Basis and Operational Data

5	YEARLY PERFORMANCE RATIOS	UNITS	DATA	COMMENTS / CLARIFICATIONS
5.30	Year 30	%		

Table 6: Annual Degradation Factor

6	ANNUAL DEGRADATION FACTOR	UNITS	DATA	COMMENTS / CLARIFICATIONS
6.1	Year 1	%		Starting at the Substantial Completion Payment Date
6.2	Year 2	%		max 0.5% for years 2 -30
6.3	Year 3	%		
6.4	Year 4	%		
6.5	Year 5	%		
6.6	Year 6	%		
6.7	Year 7	%		
6.8	Year 8	%		
6.9	Year 9	%		
6.10	Year 10	%		
6.11	Year 11	%		
6.12	Year 12	%		
6.13	Year 13	%		
6.14	Year 14	%		
6.15	Year 15	%		
6.16	Year 16	%		
6.17	Year 17	%		
6.18	Year 18	%		
6.19	Year 19	%		
6.20	Year 20	%		
6.21	Year 21	%		
6.22	Year 22	%		
6.23	Year 23	%		
6.24	Year 24	%		
6.25	Year 25	%		

Solar BOT Scope Book: Appendix 5 Design Basis and Operational Data

Appendix 5: Design Basis and Operational Data

6	ANNUAL DEGRADATION FACTOR	UNITS	DATA	COMMENTS / CLARIFICATIONS
6.26	Year 26	%		
6.27	Year 27	%		
6.28	Year 28	%		
6.29	Year 29	%		
6.30	Year 30	%		

Table 7: Yearly Production

7	YEARLY PRODUCTION	UNITS	DATA	COMMENTS / CLARIFICATIONS
7.1	Year 1	MWh/yr		starting at the Substantial Completion Payment Date
7.2	Year 2	MWh/yr		
7.3	Year 3	MWh/yr		
7.4	Year 4	MWh/yr		
7.5	Year 5	MWh/yr		
7.6	Year 6	MWh/yr		
7.7	Year 7	MWh/yr		
7.8	Year 8	MWh/yr		
7.9	Year 9	MWh/yr		
7.10	Year 10	MWh/yr		
7.11	Year 11	MWh/yr		
7.12	Year 12	MWh/yr		
7.13	Year 13	MWh/yr		
7.14	Year 14	MWh/yr		
7.15	Year 15	MWh/yr		
7.16	Year 16	MWh/yr		
7.17	Year 17	MWh/yr		
7.18	Year 18	MWh/yr		
7.19	Year 19	MWh/yr		
7.20	Year 20	MWh/yr		
7.21	Year 21	MWh/yr		
7.22	Year 22	MWh/yr		
7.23	Year 23	MWh/yr		

Appendix 5: Design Basis and Operational Data

7	YEARLY PRODUCTION	UNITS	DATA	COMMENTS / CLARIFICATIONS
7.24	Year 24	MWh/yr		
7.25	Year 25	MWh/yr		
7.26	Year 26	MWh/yr		
7.27	Year 27	MWh/yr		
7.28	Year 28	MWh/yr		
7.29	Year 29	MWh/yr		
7.30	Year 30	MWh/yr		



Solar BOT Scope Book

Appendix 6

Key Equipment Datasheets

REVISION RECORD			
Revision No.	Approval Date	Section / Page Revised	Reason / Description of Change
0	9/14/2023	All	Original Publication
25-1	5/19/2025	All	Editorial Updates
26-1	3/3/2026	All	Editorial Updates

Appendix 6: Equipment Data Sheets

Seller to include equipment datasheets for the following equipment:

- Solar PV module
- PCS
- Tracker
 - Include ASCE Design Category
 - Include post size, length
 - Include pile corrosion mitigation methodology (e.g., galvanization to ASTM A123)
- Wire management strategy
- Electrical BOS: Combiner box, DC cable manufacturer, medium voltage cable manufacturer



Solar BOT Scope Book

Appendix 7

Project Performance Test Procedure

REVISION RECORD			
Revision No.	Approval Date	Section / Page Revised	Reason / Description of Change
25-1	5/19/2025	All	Original Publication
26-1	3/3/2026	Cover	General Updates

Appendix 7: Project Performance Test Procedure

1 PURPOSE

The performance tests consist of the Availability Test and the Capacity Test.

The Availability Test will verify the PV Plant is fully commissioned and ready for commercial operation by demonstrating all inverters are able to operate reliably as designed for at least five consecutive days. The Availability Test may run in parallel to the Capacity Test, provided the other tests do not negatively impact the inverter or plant operation.

The Capacity Test will verify the plant is fully operational and ready for commercial operation by achieving the Minimum Guaranteed Capacity Ratio and Guaranteed Capacity Ratio. The Capacity Test shall be performed in general accordance with ASTM E2848 (Standard Test Method for Reporting Photovoltaic Non-Concentrator System Performance) and ASTM E2939 (Standard Practice for Determining Reporting Conditions and Expected Capacity for Photovoltaic Non-Concentrator Systems) and the requirements defined herein.

2 DEFINITIONS

2.1 General Terms

Multiple Measurements – Any measurement device or sensor where multiple devices or sensors measure the same parameter.

Revenue Meter – The revenue meter for the Project as agreed by the Parties.

2.2 Availability Test Terms

Availability Test – A short term, plant wide test used to verify the inverters and substation are capable of operating as designed and in a reliable manner.

Availability Test Calculator – An Excel file or other Buyer-approved file type used to calculate the Measured Availability during the Availability Test Measurement Period.

Availability Test Measurement Period – A five day period during which the Availability Test is conducted during full plant operation, as such period may be extended as permitted in sections 3.9 and 3.10.

Availability Test Procedures – A detailed plan for administering the Availability Test.

Availability Test Report – A summary report of the Availability Test results.

Eligible Time Intervals – Total number of time intervals during the Availability Test Measurement Period where the plane-of-array (POA) irradiance is greater than the irradiance corresponding to the minimum input voltage of the inverters and the substation is operating and injecting electricity to the grid. The selected time interval shall be 1 minute.

Guaranteed Availability – A Measured Availability of the Project as defined in Appendix 5.

Inverter Operational Time Intervals – For each inverter, the total number of Eligible Time Intervals during Availability Test Measurement Period when the inverter is in normal operation, as intended by design, and producing power.

Measured Availability – As defined in section 3.13, a percentage (rounded up or down to the nearest 0.1%), calculated as the quantity of inverter operational time intervals divided by the quantity of eligible time intervals multiplied by the number of inverters.

Appendix 7: Project Performance Test Procedure

2.3 Capacity Test Terms

Capacity Test – A short-term, plant-wide test used to verify the Seller-provided equipment is capable of operation at or above its Minimum Capacity Ratio and Guaranteed Capacity Ratio.

Capacity Test Calculator – An Excel tool used to calculate the Target Capacity and Measured Capacity for the Capacity Test Measurement Period.

Capacity Test Measurement Period – The period when the Capacity Test is performed, which period shall be at least three days, and shall continue, consecutively, for up to twelve additional days until the requirements of this Performance Test Guideline have been met.

Capacity Test Procedures – A detailed plan for administering the Capacity Test.

Capacity Test Report – A summary report of the Capacity Test results.

Project Capacity Model – The Seller-provided generation model for the Capacity Test using the software program PVsyst.

Reporting Conditions – The POA irradiance, ambient temperature, and wind speed calculated from the measured data taken during the Capacity Test.

2.4 Capacity Test - Capacity and Capacity Ratio Definitions

Target Capacity – The target capacity as calculated using the Project Capacity Model and the procedures outlined in this Performance Test Guideline.

Tested Capacity – The test period measured capacity as calculated using the procedures outlined in this Performance Test Guideline.

Tested Capacity Ratio – The Tested Capacity divided by the Target Capacity, calculated to the nearest 0.1%.

3 AVAILABILITY TEST PROCEDURE GUIDELINE

3.1 Draft Availability Test Procedure

A draft Availability Test Procedures shall be submitted to the Buyer by the Seller for Buyer's review and comment at a minimum sixty days prior to the start of the first Availability Test.

3.2 Final Availability Test Procedure

The final Availability Test Procedure as agreed to by Buyer shall be submitted fourteen days prior to the start of the Availability Test.

3.3 Notice

The Seller shall give written notice to the Buyer of the start of the Availability Test (including any re-performance thereof) ten days prior to the first Availability Test and forty-eight hours prior to subsequent Availability Tests.

3.4 Test Performance

Seller shall perform the Availability Test in accordance with the final approved Availability Test Procedures.

Appendix 7: Project Performance Test Procedure

3.5 Minimum Test Period

The minimum Availability Test Measurement Period shall last no less than five consecutive days. For three of the five days, the site must obtain a minimum output of 60% nameplate rating for a minimum of two hours per day.

3.6 Data Sampling

During the Availability Test Measurement Period, irradiance data shall be sampled at no greater than five second intervals. Irradiance data shall be reported at no greater than one minute intervals, consisting of averaged five second sampled data. Revenue meter data (indicating energy injection at the substation) and inverter power generation data shall be sampled and reported at the intervals required for irradiance, as noted above. Other data shall be sampled and reported at no greater than one minute intervals. All data shall be reported in time-synchronized intervals.

3.7 Data Intervals

Data intervals subject to the following conditions may allow exclusion of the data interval period from Eligible Time Interval set, as defined below:

3.7.1 Missing Data

Missing records shall be marked as missing with a non-numeric identifier. Missing records shall be considered as unavailable time if occurring during Eligible Time Intervals, unless Seller can prove availability during this period with other test data or collected data of the test dataset.

3.7.2 SCADA Equipment Malfunction

Data records with invalid Measured Parameters (e.g. all sensor readings reported as out of range by the SCADA) shall also be marked as invalid records and shall be considered as unavailable time if occurring during Eligible Time Intervals, unless Seller can prove availability during this period with other test data or collected data of the test dataset.

3.7.3 Below Minimum Irradiance

All data intervals with a minimum POA irradiance Measured Parameter of less than that corresponding to the minimum input voltage rating of the inverter shall be marked as irradiance too low and may be excluded from Eligible Time Interval set. Minimum POA irradiance value shall be calculated and mutually agreed to with Buyer based on final PV Plant equipment selection and design.

3.8 Data Quality

During the Availability Test Measurement Period the Seller shall record all inverter power, revenue meter, and POA irradiance data in accordance with the Data Quality and Instrumentation Requirements set forth in this Performance Test Guideline. Such data shall be made available during and after the test as requested by Buyer.

3.9 Plant-Related Interruptions

During the Availability Test, the site must run autonomously without manual intervention and the Seller shall document all inverter or plant-related interruption events, including the identification of the event, the reason for the interruption, the time and duration of the event and any corrective actions undertaken. In the event that inverter or plant-related interruptions do occur, the Seller has the option to restart the Availability Test,

Appendix 7: Project Performance Test Procedure

provided that Seller shall notify Buyer thereof and provide detailed documentation of identified issues and proposed resolution to rectify such issues prior to re-performing the Availability Test.

3.10 Grid-Related Interruptions

During the Availability Test, the Seller shall document all interruption events caused by grid operations including the identification of the event, the reason for the interruption, the time and duration of the event, and any corrective actions undertaken. To the extent that such interruption event was not caused by the Seller or the Work, such events are excusable and the test shall be extended by the amount of excluded time on a minute-by-minute basis to achieve five complete days of data.

3.11 Normal Substation and Inverter Operation

3.11.1 Substation

The project collector substation shall be available during daytime periods as to not inhibit the inverters' ability to operate normally. Substation alarms and warnings which do not affect the plant's ability to safely export power to the grid, such as communications errors or faults from non-essential equipment, shall not count against the availability calculation. However, if there are any faults or events which affect the plant's ability to export power to the grid, such as a breaker trip due to a fault within the facility, then the downtime shall count against the availability calculation. Any downtime caused by Buyer Furnished Equipment (e.g., Main Power Transformer) shall be excluded from the Availability Test Measurement Period.

3.11.2 Inverters

The inverters shall be permitted to operate with "runnable" faults, such as communications errors or other warnings which do not inhibit the inverters' ability to export the expected power at the given operating condition, without counting against availability calculation. However, if the inverter(s) experience an event which affects the ability to export power, such as an Insulated Gate Bipolar Transistor (IGBT) fault, over-temperature alarm, or voltage/current alarms, then the downtime shall count against the availability test calculation.

3.12 Continued Operation

The Project must be capable of continued operation, without intermittency or downtime during the Availability Test Measurement Period except for excused events described in the preceding paragraphs of this section. If the Measured Availability of the Project does not meet or exceed the Guaranteed Availability, the Seller shall identify and promptly resolve the source of the problem and promptly perform the Availability Test again in accordance with these procedures until the Measured Availability of the Project achieves the Guaranteed Availability.

3.12.1 Termination of Test

If the Availability Test is terminated, the Seller shall notify the Buyer in writing. The root cause of the termination shall be identified and modifications or repairs made before any subsequent Availability Test is considered successful.

3.12.2 Test Extension

Seller may choose to extend the duration of the Availability Test Measurement Period to achieve Guaranteed Availability. If Seller chooses to extend the Availability Test Measurement Period, all Eligible Time Intervals, from the previously declared test starting point through completion of the Availability Test Measurement Period, shall be included in the final Measured Availability calculation.

Appendix 7: Project Performance Test Procedure

3.12.3 Response Time

Once an Availability Test has been started, any modifications to the Project to modify equipment or components or repair incidents such as trips, faults or failures, to restore the full site toward achieving successful Inverter Operational Time Intervals shall have an operational “response time” unavailability period assessed to the Availability Test Measurement Period. Seller may choose either of the following approaches for implementing the “response time” assessment and in responding to any equipment failures during the Availability Test Measurement Period. Whichever approach is determined shall be used for the duration of that Availability Test Measurement Period. If subsequent Availability Tests are performed Seller may choose a different approach, but must use the decided approach for the full duration of each test.

- a. If a failure occurs, Seller shall wait the one hour “response time” duration to begin troubleshooting and performing repairs. Unavailable time for Availability calculation shall include one hour “response time” + time to complete troubleshooting, repair, and release of equipment for operation.
 - i. If additional or subsequent failure occurs on site in the time period between the start of the one hour “response time” window and within one hour of completion of the repair no additional “response time” delay is required and only time required to repair the additional / subsequent failure, by same person, will be assessed for the Availability calculation.
 - ii. If additional or subsequent failure occurs on site within the one hour time period after repair completion, no “response time” will be assessed, only the actual time to complete troubleshooting, repair, and release of equipment for operation shall be assessed in the Availability calculation.
 - iii. If, during the response + repair time period, irradiance levels on site drop to a point where all adjacent inverters have entered shutdown / standby mode and remain in shutdown / standby, these time intervals will not be counted as Eligible Time Intervals for the Availability calculation.
- b. If a failure occurs, Seller may respond immediately and begin the troubleshooting, repairs, and release to operation effort. A one hour ‘response time’ period of unavailability will be assessed, in addition to the time to complete troubleshooting, repair, and release of equipment for operation, to the test period data for the Availability Calculation during post processing of data.
 - i. Any additional or subsequent failures shall follow the same approach in steps 3.12.3.a.i through 3.12.3.a.iii in regard to unavailable time durations to be used in the post processing of the test data.

3.12.4 Nighttime Repairs

Nighttime repairs or system modifications will be allowed if prompted by equipment error or fault codes and alarm signals received in the SCADA/DAS, however nighttime system repairs or modifications of the nature of tuning the system to improve system reliability shall not be made during the Availability Test Measurement Period.

3.13 Measured Availability

The result of the Measured Availability shall be calculated as follows, where “n” is the total number of inverters:

$$\text{Measured Availability} = \frac{\sum_{i=1}^n \text{Inverter Operational Time Intervals}_i}{\text{Eligible Time Intervals} * n}$$

Appendix 7: Project Performance Test Procedure

3.14 Availability Test Report

Seller shall provide the draft and final Availability Test Reports according to timeline defined in this agreement. Buyer shall have ten Business Days to accept or reject the results of the draft Availability Test Report and provide in writing any comments of Buyer on such draft Availability Test Report. In the event that Buyer rejects all or any part of the draft Availability Test Report, Seller shall, within five Business Days thereafter address any comments of Buyer and re-submit the draft Availability Test Report to Buyer. This procedure shall continue until Buyer accepts the draft Availability Test Report; the acceptance of such Availability Test Report shall not be unreasonably withheld. Any dispute regarding the results of the Availability Test or the Availability Test Report shall constitute a Dispute as described in the Contract. The Availability Test Calculator, along with all raw data and QC disposition for each input data record, shall be provided electronically to the Buyer with the Availability Test Report.

4 CAPACITY TEST PROCEDURE GUIDELINE

A draft of the Capacity Test Procedures shall be submitted to the Buyer by the Seller for Buyer's review and comment in accordance with the Contract. Draft Capacity Test Procedures shall include the native format of the draft Capacity Test Calculator.

The Seller shall give written notice to the Buyer of the start of the Capacity Test (including any re-performance thereof) as required pursuant to the Contract.

Seller shall perform the Capacity Test in accordance with the final, approved Capacity Test Procedures.

Capacity Test Procedures shall identify anticipated Reporting Conditions and Target Capacities using the Project Capacity Model, and data filters described below. Final Reporting Conditions and Target Capacity will be updated in the Capacity Test Calculator and Capacity Test Report, using the allowable data points after all data filtering, following the Capacity Test Measurement Period.

The Capacity Test Measurement Period shall last no less than three consecutive days. If the Minimum Datapoints requirement is not met during such three day period, the Capacity Test Measurement Period shall be extended for consecutive days until the Minimum Datapoints requirement is met; provided that

- (a) All datapoints used for development of the Capacity Test Minimum Datapoints must fall within a fifteen consecutive Calendar Day timeframe (unless extension is allowed by Buyer, up to a thirty Calendar Day maximum timeframe)
- (b) If the Minimum Irradiance criteria set forth is causing a delay in the test and pushing it beyond the Guaranteed Project Substantial Completion Date, or as otherwise agreed to by the Parties, the test procedure may be modified per Buyer approval in written form.

4.1 Measured Parameters

The following measured parameters shall be measured during the Capacity Test (the "Measured Parameters").

4.1.1 POA Irradiance

An estimate of the average irradiance incident upon the PV array in the Project, as measured by the Project meteorological stations. No provision is allowed for shading, so any significant shading, resulting from conditions other than Project equipment shading and permanent features within and outside of the Project boundary, during any data interval is an acceptable cause to exclude that data record from the regression.

Appendix 7: Project Performance Test Procedure

4.1.2 Rear Plane of Array (RPOA) Irradiance

An estimate of the average irradiance incident upon the backside of the PV array in the Project, as measured by the Project meteorological stations. Any significant shading, resulting from conditions other than Project equipment shading and permanent features within and outside of the Project boundary, during any data interval is an acceptable cause to exclude that data record from the regression.

4.1.3 Global Horizontal Irradiance

An estimate of the average irradiance as measured by the Project meteorological stations. No provision is allowed for shading, so any significant shading, resulting from conditions other than Project equipment shading and permanent features outside of the Project boundary, during any data interval is an acceptable cause to exclude that data record from the regression.

4.1.4 Site Albedo

An estimate of the average ground albedo factor for the project measured by the Project meteorological stations.

4.1.5 Ambient Temperature

As recorded by the Project meteorological stations.

4.1.6 Wind Speed

As recorded by the Project meteorological stations.

4.1.7 Revenue Meter Power Generation

Power produced by the Project as recorded by the Revenue Meter during the Capacity Test Measurement Period.

4.1.8 Inverter-Level Power Generation

AC output data for each inverter, measured at the AC terminals of the inverter, shall be provided for the purposes of identifying periods of inverter clipping.

4.1.9 Inverter-Level Power Input

DC input data for each inverter, taken as the summation of power input from DC feeders and measured at each inverter's DC terminals, shall be provided.

4.2 During the Capacity Test Measurement Period

The irradiance Measured Parameter shall be sampled at no greater than five second intervals and reported at no greater than one minute intervals, consisting of averaged five second sampled data. The Power Generation Measured Parameters shall be sampled and reported at the intervals required for irradiance, as noted above. Other Measured Parameters shall be sampled and reported at no greater than one minute intervals. All data points shall be reported, and they shall be in time-synchronized intervals.

All minute data points shall be reported. Filtering shall be clearly demonstrated in accordance with the procedures outlined below. No valid data points shall be filtered.

Appendix 7: Project Performance Test Procedure

4.2.1 Missing Data

Missing records from any of the Measured Parameters shall be marked as missing with a non-numeric identifier. Missing records shall not have a value included in the analysis but shall be documented. Data intervals associated with this missing data shall be excluded from the test data set.

4.2.2 SCADA/DAS Equipment Malfunction

Data records with invalid Measured Parameters (e.g. all sensor readings reported as out of range by the SCADA/DAS) shall also be marked as invalid and excluded from the test data set.

4.2.3 Below Minimum Irradiance

To avoid large uncertainty in results due to increased impact of variable losses at low irradiance, all records with a minimum POA irradiance Measured Parameter of less than 400 W/m² shall be marked as “irradiance too low” and excluded from the evaluated test data set.

4.2.4 Unstable irradiance

Irradiance Measured Parameters shall be deemed stable if

- (a) All individual sensor readings are within 25 W/m² of the average of all the sensor readings (consideration may be given to allowing individual sensor readings within 5% percent of the average of all the sensor readings if this filtering criteria is creating issues with achieving Minimum Datapoints requirement, as agreed to between parties.)
- (b) The average of all sensor readings is not more than 10% greater or less than the previous one-minute interval reading.

If both conditions above are not met, the irradiance will be deemed unstable, flagged and those data intervals for the full site shall be excluded from the evaluated test data set. Alternatively, if agreed to between Parties, unstable irradiance filtering criteria methodology from the ASTM E2848 may be used.

4.2.5 Inverter clipping

Any intervals where the power output of one (or more) inverters is greater than 98.0% of the rated or programmed power limit. If the condition above is met, such data points shall be excluded from the evaluated test data set.

4.2.6 Array shading by environmental conditions (e.g. frost, snow, or debris)

Onsite observers shall record time intervals when such conditions exist as the Capacity Test progresses. Photographic evidence of array conditions shall be provided. Data intervals associated with these shading periods shall be excluded from the evaluated test data set.

4.2.7 Wind Speed

Any intervals where the average wind speed is greater than 15 meter per second shall be excluded from the evaluated test data set.

4.3 Minimum Data Collection

Data will be collected for a minimum of 3 days and until the Minimum Datapoint requirement, at least 750 minutes of allowable data points, are collected.

Appendix 7: Project Performance Test Procedure

4.4 Irradiance and Bifacial Gain Approach

The total irradiance (E_{TOTAL}) for the Tested Capacity data is calculated as the sum of the collected POA (E_{POA}) and RPOA (E_{RPOA}) irradiance values with the E_{RPOA} measurements adjusted based on module bifaciality and backside shading by the tracker structure. This calculation is outlined by the following equation:

$$E_{TOTAL} = E_{POA} + (E_{RPOA} * \phi) * (1 - S_r)$$

Where:

- ϕ is the bifaciality factor of the module PAN file as provided by Seller (the 3rd party verified PAN file will be used if available).
- S_r is the rear structural shading loss percentage utilized in the Project Capacity Model representing the rear shading of module cells from torque tubes.

The total irradiance (E_{TOTAL}) for the Target Capacity data is calculated as the sum of the collected POA (PVsyst - GlobInc) and RPOA (PVsyst - GlobBak) irradiance values with the E_{RPOA} measurements adjusted based on module bifaciality. This calculation is outlined by the following equation:

$$E_{TOTAL} = GlobInc + (GlobBak * \phi)$$

Where:

- GlobInc is the Incident global irradiation in the collector plane (E_{POA})
- GlobBak Global irradiance on the rear side of collector plane (E_{RPOA}) which accounts for rear shading
- ϕ is the bifaciality factor of the module as provided in the module specification sheet.

For clarity, all references to the irradiance reporting condition, irradiance bands, maximum irradiance, etc. will utilize the total irradiance (E_{TOTAL}) per the equation above.

4.5 Determining Target Capacity Data

The Target Capacity Data (sixty days of data) is derived from the Project Capacity Model Hourly Data (three hundred and sixty-five days of data).

Remove all data from the Project Capacity Model Hourly Data except for sixty day period centered on the Capacity Test Measurement Period to create the Target Capacity Data. The Target Capacity Data, after post-processing, must contain at a minimum the POA irradiance, the ambient temperature, wind speed, inverter energy output, modeled power generation, shade loss, and clipping loss (GlobInc, GlobBak, T_{Amb}, WindVel, E_{OutInv}, POI Limited, ShdBLss, and IL P_{max}) respectively.

If the Capacity Test Measurement Period is an even number of days, then the sixty days will be evenly distributed before and after the Capacity Test Measurement Period.

For example, if the Capacity Test Measurement Period is July 1st-4th, then the Target Capacity Data would be June 2nd – August 2nd.

If the Capacity Test Measurement Period is an odd number of days, then center the sixty-day period such that there is one additional day on the back end of the Capacity Test Measurement Period. This will allow up to two additional days to be added to the Capacity Test Measurement Period without shifting the Target Capacity Data.

For example, if the Capacity Test Measurement Period is July 1st-5th, then the Target Capacity Data would be June 3rd – August 3rd.

Import the Target Capacity Data into the Capacity Test Calculator.

Solar BOT Scope Book: Appendix 7 Project Performance Test Procedure

Appendix 7: Project Performance Test Procedure

4.6 Determining Reporting Conditions

Reporting conditions shall be selected according to ASTM E2939 and the additional irradiance requirements defined herein.

4.7 Determining Capacities and Capacity Ratios

Using the Capacity Test Calculator and the data filtering described herein, calculate the Target Capacity linear-regression coefficients, the Target Capacity, the Tested Capacity linear-regression coefficients, and Tested Capacity, and the Tested Capacity Ratio using the Equations below:

4.7.1 Tested Capacity

Calculate the Tested Capacity linear-regression coefficients of the Filtered Measured Data Records using the Microsoft Excel Plug-in.

Calculate the Tested Capacity using the following formula:

$$\text{Tested Capacity} = E_{TOTAL_RC} * (a_1 + a_2 * E_{TOTAL_RC} + a_3 * T_{RC} + a_4 * v_{RC})$$

Where:

- E_{TOTAL_RC} = Irradiance at the Reporting Conditions
- T_{RC} = Ambient temperature at the Reporting Conditions
- v_{RC} = Wind Speed at the Reporting Conditions
- a_1, a_2, a_3, a_4 = Multilinear regression coefficients calculated using Excel Plug-in

4.7.2 Target Capacity

Calculate the Target Capacity linear-regression coefficients of the Target Capacity Data using the Microsoft Excel Plug-in.

Calculate the Target Capacity using the following formula:

$$\text{Target Capacity} = E_{TOTAL_RC} * (b_1 + (b_2 * E_{TOTAL_RC}) + (b_3 * T_{RC}) + (b_4 * v_{RC}))$$

Where:

- E_{TOTAL_RC} = Irradiance at the Reporting Conditions
- T_{RC} = Ambient temperature at the Reporting Conditions
- v_{RC} = Wind Speed at the Reporting Conditions
- b_1, b_2, b_3, b_4 = Multilinear regression coefficients calculated using Excel Plug-in

4.7.3 Calculate Tested Capacity Ratio

Calculate the Tested Capacity Ratio using the following formula:

$$\text{Tested Capacity Ratio (\%)} = \frac{\text{Tested Capacity}}{\text{Target Capacity}} * 100$$

For clarity, the Tested Capacity Ratio is not to be adjusted up or down based on test uncertainty. The straightforward value calculated as the Tested Capacity Ratio shall be used to determine the result of the Capacity Test.

Appendix 7: Project Performance Test Procedure

4.8 Capacity Test Report

Seller shall provide the draft and final Capacity Test Reports. Buyer shall have ten Business Days to accept or reject the results of the draft Capacity Test Report and provide in writing any comments of Buyer on such draft Capacity Test Report. In the event that Buyer rejects all or any part of the draft Capacity Test Report, Seller shall, within five Business Days thereafter address any comments of Buyer and re-submit the draft Capacity Test Report to Buyer. This procedure shall continue until Buyer accepts the draft Capacity Test Report; the acceptance of such Capacity Test Report shall not be unreasonably withheld. Any dispute regarding the results of the Capacity Test or the Capacity Test Report shall constitute a Dispute as described in the Contract.



Solar BOT Scope Book

Appendix 8

Project Site Map

REVISION RECORD			
Revision No.	Approval Date	Section / Page Revised	Reason / Description of Change
0	9/14/2023	All	Original Publication
25-1	5/19/2025	All	General Updates
26-1	3/3/2026	All	General Updates

Appendix 8: Project Site Map

[INSERT SITE MAP HERE]

Site Physical Address:

Appendix 8 cannot be updated without approval of Buyer.



Solar BOT Scope Book

Appendix 9

Approved Vendors List

REVISION RECORD			
Revision No.	Approval Date	Section / Page Revised	Reason / Description of Change
0	9/14/2023	All	Original Publication
25-1	5/19/2025	All	General Updates
26-1	3/3/2026	All	General Updates

Appendix 9: Approved Vendors List

A vendor appearing in the list below as an Approved Vendor for a particular type of equipment, system, or item shall not be an Approved Vendor for the manufacture of any other type of equipment, system, or item unless it is also identified therein as an Approved Vendor for such other type of equipment, system, or item. The inclusion of an entity on the list does not mean that such entity has been determined to satisfy or been pre-approved with respect to the requirements in, and other terms of, this Scope Book or the Agreement that apply, directly or indirectly, to EPC Contractors, vendors, manufacturers, or providers of equipment, systems, or items on (or not on) the list. Nothing in this Appendix is intended to or shall limit the application of such requirements or terms, directly or indirectly, to any entity on the list.

Vendors or EPC Contractors not included in the list shall be considered and permitted upon Buyer's approval in its sole and absolute discretion. Vendors and EPC Contractors submitted for approval shall be evaluated based on a combination of installed capacity of largest facilities, total installed capacity of all facilities, bankability of product, company net worth, legal standing of the company, safety record and policies, quality assurance/quality control procedures, and other factors.

Approved Manufacturers List					
Major Equipment – Excludes major equipment covered in Appendix 1 - Collector Substation and Appendix 2 - High Voltage Overhead Transmission Line					
PV Modules	Astronergy	Boviet	Canadian Solar	First Solar	Hanwha Q-Cells
	JA Solar	Jinko	LONGi	Runergy	Trina Solar
Inverters	GE	TMEIC	Sungrow	SMA	Ingeteam
	Siemens	ABB			
Single Axis Tracking System	Array Technologies, Inc	NexTracker	Game Change	Valmont Solar	Nclave
	PV Hardware	TerraSmart	Ideematec		
Fixed Tilt Racking System	Game Change	Kloeckner Metals (Sol Components)	Solar FlexRack	Ampacity Renewables	TerraSmart
	Aerocompact	Sollega			
LV/MV Transformer	ABB	Central Moloney	ERMCO	Virginia Transformer Corporation	Eaton
Switchgear	ABB	Eaton	GE	Powell	
Balance of Plant					
Combiner / Recombiner Boxes	SolarBOS	Shoals	Bentek	Olson	

Appendix 9: Approved Vendors List

Approved Manufacturers List					
Major Equipment – Excludes major equipment covered in Appendix 1 - Collector Substation and Appendix 2 - High Voltage Overhead Transmission Line					
Disconnects	Schneider	Siemens	Eaton	ABB	SMA
Data Logger	Campbell Scientific	Kipp and Zonen			
Pyranometer	Kipp and Zonen	Eppley Laboratory	EKO		
Power Distribution Center	Powell	Zachry	PACS	Alstom	

EPC Contractors:

EPC Contractors					
Blattner	IEA Constructors	Moss	White Construction	Boldt	Kiewit
Aristeo	Rosendin	Depcom Power	RES	SOLV Energy	McCarthy
Primoris	Mortenson	Cupertino Electric Inc.	WHC	Wood	Granite Construction
Henkels and McCoy	Aldridge Electric	Bowen Engineering	Conductor Power	Barton Malow	Rachel Contracting
J. Ranck	Black & Veatch	MYR Group	Wanzek		



Solar BOT Scope Book

Appendix 10

NERC Requirements

REVISION RECORD			
Revision No.	Approval Date	Section / Page Revised	Reason / Description of Change
0	9/14/2023	All	Original Publication
25-1	5/19/2025	All	Editorial corrections
26-1	3/3/2026	All	Editorial corrections

Appendix 10: NERC Requirements

Items to be updated and current as of the Effective Date of the Agreements and as required thereafter pursuant to the Scope Book.

NERC Standard	Title	Deliverable	Due Date
CIP-002-5.1a	Cyber Security - BES Cyber System Categorization	1) Provide real MW power capability of generator 2) Provide MVAR nameplate rating capability of generator	At FNTF
CIP-003-8	Cyber Security — Security Management Controls	1) Provide Physical Security Controls 2) Provide Electronic Access Controls 3) Provide Transient Cyber Assets and Removeable Media if required	60 Days Prior to Substantial Completion
COM-001-3	Communications	Documentation showing the interpersonal communications channels (phones, backup systems) exist and are functioning.	30 Days Prior to Substantial Completion
FAC-002-2	Facility Interconnection Studies	Evidence of the coordination/communication with the TO as part of GIA development	120 Days Prior to Substantial Completion
FAC-008-5	Facility Ratings	Facility Rating Report with supporting documentation supporting each equipment rating	60 days prior to energization for IFC rating report, if changes are necessary a final IFC rating report to be resubmitted no later than 60 days prior to Substantial Completion.
MOD-032-1	Data for Power System Modeling and Analysis	Evidence that all required data has been provided.	30 days prior to Substantial Completion Final updates (if required) within 90 days of Post Substantial Completion
PRC-005-6	Protection System, Automatic Reclosing, and Sudden Pressure Relaying Maintenance	1) List of equipment that must be in the PSMP plan. Must include all facility equipment generation and substation. (Entergy uses a PRC-005 Component list). 2) Test reports or documentation that all listed equipment has been tested including the dates of testing.	List of equipment and test documentation: 90 days prior to Substantial Completion
PRC-006-5 PRC-006-PRC-006-SERC-3	Automatic Underfrequency Load Shedding	Attestation that no UFLS is included in facility design OR Specific documentation for under frequency/over frequency of protection and control devices included in the facility (including the control systems).	90 Days Prior to Substantial Completion
PRC-012-2	Remedial Action Schemes	Attestation that no RAS is included in facility design. OR Specific documentation for remedial action scheme settings of protection and control devices included in the facility (including the control systems).	30 Days prior to Substantial Completion

Appendix 10: NERC Requirements

NERC Standard	Title	Deliverable	Due Date
PRC-017-1	Remedial Action Scheme Maintenance and Testing	Attestation that no RAS is included in facility design. OR Specific documentation for remedial action scheme settings of protection and control devices included in the facility (including the control systems).	30 Days prior to Substantial Completion
PRC-019-2	Coordination of Generating Unit or Plant Capabilities, Voltage Regulating Controls, and Protection	Relay setting documentation and a specific report showing that all limiters operate before protection and control devices including the control systems and the protective system limits damage to equipment.	90 Days Prior to Substantial Completion
PRC-023-6	Transmission Relay Loadability	Attestation that PRC-023-4 does not apply or evidence of compliance	90 Days Prior to Substantial Completion
PRC-024-3 PRC-029-1	Frequency and Voltage Protection Settings for Generating Resources	Relay setting documentation and a specific report showing the frequency and voltage responsive relays and control function device comply with the setting requirements of PRC-024 by not tripping in the "No-Trip" zone.	90 Days Prior to Substantial Completion
PRC-025-2	Generator Relay Loadability	Relay setting documentation and a specific report showing the load responsive relays comply with the setting requirements of PRC-025.	90 Days Prior to Substantial Completion
PRC-026-2	Relay Performance During Stable Power Swings	Relay Setting Documentation and analysis showing the load responsive relays will not trip during power swings.	90 Days Prior to Substantial Completion
PRC-027-1	Coordination of Protection Systems for Performance During Faults	Complete package of relays setting documents including analysis to support review by Entergy Transmission. Documentation should include varication of electrical coordination for expected fault currents.	Should be provided before equipment is energized.
PRC-028-1	Disturbance Monitoring and Reporting Requirements for Inverter-Based Resources	1) Report showing SER (Sequence of Events Recording) data for the breaker(s) associated with each MPT, collector buses, shunt static and dynamic reactive devices. 2) Report showing installation and specifications for DFR (Digital Fault Recording) that meets PRC-028 R3, R6 will be needed for: a) High side of each MPT b) Collector feeder breaker(s) c) Any shunt dynamic reactive devices d) Report showing installation and specifications for DDRs that meets PRC-028 R5, R6 will need to be installed on each MPT	60 days prior to Substantial Completion
VAR-002-4.1	Generator Operation for Maintaining Network Voltage Schedules	1) Report showing facility design must include alarms for AVC mode off, Power System Stabilizer off (if part of plant configuration), and out of voltage schedule. 2) Report showing pop-up notification in the HMI telling the operator that changing the AVR/controller from AVR	60 Days Prior to Substantial Completion

Appendix 10: NERC Requirements

NERC Standard	Title	Deliverable	Due Date
		to any other mode (PF, VAR control) MUST have documented/written approval from the TCC before changing modes.	



Solar BOT Scope Book

Appendix 11

Project Controls

REVISION RECORD			
Revision No.	Approval Date	Section / Page Revised	Reason / Description of Change
0	9/14/2023	All	Original Publication
25-1	5/19/2025	All	General Updates
26-1	3/3/2026	All	General Updates

Appendix 11: Project Controls

Our mutual goal is to have a safe construction environment in which we deliver a quality plant, on time, at the agreed upon cost, that can be safely, timely and efficiently operated for the next several decades by the Entergy Operating Company we are building it for. **A key element of successful project delivery is having execution plans that clarify roles, responsibilities, and expectations for the various companies and persons managing the execution effort.** It is presumed that Entergy is contracting with companies experienced in executing the work and that our partners already have their own set of plans. Entergy's execution team will then review our partners' plans to establish a confidence-level that the work will be executed safely, efficiently and to scope, and also offer suggestions based on lessons learned.

Entergy will not be providing templates of the required plans, because if we were to do so, we risk diminishing the ownership that a partner would have if the plan wasn't developed by their company with their own subject matter experts. However, the below guidelines may help provide context as to Entergy's minimum information expectations.

Entergy is not requiring its partners to rewrite or reformat their existing plans, we just want to confirm that our partners have established a methodical approach that serves as a roadmap for their internal management and their contractors to ensure successful project execution. Some plans might be stand-alone due to their complexity or importance, i.e. Environmental, Health and Safety or Quality plans, while other information may be embedded in an overall Project Execution Plan, as contemplated below.

1. Health, Safety, and Environmental Plan

Purpose: Protocols to safeguard the health and safety of all persons who visit/work on the site, as well as environmental protections for the site, as well as adjacent landowners/public/communities.

- Developer's and/or EPC's Corporate HSE policy, setting forth minimum expectations and confirmation that all subcontractors' plans meet the minimum expectations
- Safety Programs
 - General Safety plan
 - Responsibilities of Contractors, Employees and Visitors
 - Subcontractor safety plans
 - Site specific safety protocols, including, but not limited to: drug testing, surveillance, on-site training/orientation, stop work authority, hazardous materials, LOTO-High Energy, emergency response, record retention, incident follow-up, commitment to action if a safety protocol and/or safeguard is violated, etc.
 - Reporting information: Timeline for reporting severe incidents between the contractors (sub to EPC to Developer) and to the Buyer, statistics information, incident investigations/lessons learned
 - Describe the steps that will be taken to educate and inform local law and EMS personnel about the site to increase their efficiency should their assistance be needed
- Extreme Weather / Hurricane Plan
 - Guidelines for protecting the workers and preparing the project site and loose materials for extreme weather i.e. hurricanes, tornadoes, freeze/ice-snow,
 - Establishing management communication before, during and after severe weather events, and

Appendix 11: Project Controls

- Assessing the site after an extreme weather event
- Environmental
 - Protection of the project land and biodiversity, as well as adjacent land/communities/public
 - Permitting: SWPPP, SPCC, Waters of the US, et al
 - Protocols for monitoring adherence to Best Management Practices listed in the permitting
 - Protocols for ensuring compliant disposal of damaged modules or other e-waste or haz waste
 - Protocols for preventing any new ENV issues from happening
- If a Developer's intention is to submit their EPC's Environmental and/or Safety plan, then articulate how the Developer will oversight their EPC's compliance with their plan

2. Quality Assurance/Quality Control Plan

Purpose: Protocols for verification that the project is built in compliance with the Agreement, IFC drawings, the Scope of Work, and that the installation will meet the Performance Standard for a plant that can be safely maintained, and timely and efficiently operated.

- Developer's and/or EPC's Corporate QA/QC policy, setting forth minimum expectations and confirmation that all subcontractors' plans meet the minimum expectations
- Accountability of contractors
- Process control
- Design Control
- Document Control
- Reporting
- Training
- Materials Quality
- Installation Quality Assurance (PV: civil, mechanical, electrical and HV: Collector Sub, transmission, distribution)
- Equipment calibration
- Identifying and managing nonconformance
- Articulate the process for tiered inspection oversight, i.e. Subs QA their work, the EPC then QAs the subs' work, the Developer then QAs the sub's work
- If a Developer's intention is to submit their EPC's QA/QC plan, then articulate how the Developer will oversight that EPC's compliance with their stated protocols
- Include information on the onsite inspection process/program that will be conducted by the major materials OEMs' QA/QC teams, i.e. for trackers, inverters, modules, major Collector Substation components, etc.
- Required Witness Points – The following inspection points, at a minimum, shall be included in the plan. Project Inspection presence at the "Event" is required. The contractor may proceed past the point, provided, the agreed notice of "Event" is given, and the Project Manager elects not to be present at the time of "Event".

Solar BOT Scope Book: Appendix 11 Project Controls

Appendix 11: Project Controls

- SWPP compliance and initial road cut
- Medium voltage cable installation
- Pile pull test
- Inverter skid / MV rough in
- Inverter set
- DC cable / combiner box / CAB installation
- PV wire harness management
- Main step up (MSU) transformer pit
- MSU transformer set
- Backfeed
- Required Hold Points – The following hold points, at a minimum, shall be included in the plan. No work is to proceed beyond this point without Owner’s Engineer inspection witness and acceptance of the “Event” activity. Waiver of the Project presence at a hold point can only be given in writing by the Project Manager.
 - Golden Row
 - Mechanical Completion
 - Substantial Completion
 - Final Acceptance

Project Execution Plan (PEP) Overview Guidance

Purpose: A Project Execution Plan (PEP) is a governing document that establishes the means and methods to execute, monitor and control projects. In the context of the business partners working with Entergy to execute renewable projects, the PEP should contain high-level information about the project, discuss stakeholders and provide an organizational chart of the entities and persons that will manage the project. The PEP may include Design, Engineering and Construction management protocols, articulate the approach for contracting and procurement, intended methods for security of the site, people and material, how project performance will be monitored with scheduling and installation velocity tracking, identification of risks and risk-monitoring, and how documentation and required information will be transmitted. A completed PEP document shall be provided 60 days after FNTP with the final draft being provided 4 months prior to site mobilization.

The following plans can be stand-alone or grouped as one over-arching document:

3. Project Organization Plan

- Project Organization and Roles/Responsibilities
- Include primary companies (Developer and EPC), could also include Entergy’s primary contacts
- Meeting and Report Distribution Matrix (listing of personnel to be included in mtgs/reports/etc.)

Appendix 11: Project Controls

4. Engineering Plan

Purpose: Acknowledge requirements in the Agreement and the Scope Of Work (SOW) by communicating the plan to meet key deliverables and expectations.

- Articulates the engineering strategy, identify who is performing the engineering tasks
- Discuss Basis of Design document development (PV and HV)
- Provide a submittal list of ENG documents that correlates with the SOW and the engineering phase
- Design review cycle, i.e. 30-60-90 or Phase A/B/C, RFIs/tracking
 - List the deliverables that will be in each deliverable phase
 - Define what constitutes achieving IFC drawings
- Dates and Milestones for Engineering deliverables
 - PV Engineering, including civil, mechanical, electrical, Cx, et al
 - HV/Substation Engineering
 - Drawings, etc.
- Approach for developing plans defined in the Agreement/SOW, i.e. the Hot Commissioning Plan, the Performance Testing Plan, Harmonics Studies, etc.
- Establishing, implementing, and adhering to NERC-CIP requirements (as will be further detailed in the stand-alone Cyber Security Plan)

5. Document Control Plan

- Describe the method for transmitting documentation deliverables to Entergy
- Articulate the process for tracking review comments and resolution of comments (ball-in-court process) including flow diagram showing the document issue and revision / comment process to ensure alignment
- Ensure that the external team members are aware of Entergy's >10MB email attachment restrictions

6. Contracting Plan

- Articulates the contracting strategies, identify primary suppliers, discuss long-lead times
- List of anticipated contractors for major services
- Key supply risks and mitigating actions
- Narrative on actively pursuing using qualified/capable local and diverse suppliers and labor resources, and sharing this information with Entergy

7. Procurement Plan

- Articulates the procurement strategies and approach used to purchase equipment and materials for the project
- Narrative of how procurement functions through contracts and responsibilities

Solar BOT Scope Book: Appendix 11 Project Controls

Appendix 11: Project Controls

- Estimated start and end delivery dates of equipment
- Key supply risks and mitigating actions

8. Construction Plan

- Narrative of how the work will be managed and by whom, include titles and corresponding roles and responsibilities
- Articulate the planned approach to constructing the plant, from initial grading to cold and hot commissioning
- Due to the importance of commissioning (Cx), as well as the increased safety focus that is required, include discussion on the Cx plan
- Reference applicable project plans, i.e. Safety/ENV, QA/QC, Procurement, Performance Monitoring, and how the Developer/EPC will provide engagement and oversight to ensure plans are being followed
- Include specific discussion acknowledging the challenges for building in the Deep South, including weather, terrain, labor availability - list construction practices that will be implemented to ensure safety and schedule optimization
- Describe the plan to minimize items that can/will be addressed during the construction cycle to minimize elongated periods to achieve Mechanical Completion, Substantial Completion and Final Acceptance (drainage and water conveyance, high vegetation, Pre-Punch List items with the EPC, rut remediation, trash/litter, damaged components, etc.)
- Describe the oversight and communications that will occur between all entities to ensure continued focus of safety, environmental, and quality when personnel changes occur and/or conditions change on site, for example the transformation that often occurs on the site when transitioning to the Substantial Completion through Final Acceptance phase

9. Site Security Plan (Project Custody)

- Explain how the site will be secured to protect the people on site as well as the project's assets
- Ensure how the site will restrict unauthorized access
- Describe the signage for the site that will communicate authorized access requirements, i.e. project signage, main gate(s) descriptor signage, directional signs, Site Rules and Required PPE signage, explanation of authorized access / badging if applicable, speed limit signs, muster locations, Hot Cx / LOTO signage/roping (i.e. Red Rope process)
- Site access after Closing – plan to include requirement that Seller execute a Site Access Agreement with Buyer

10. Project Risk Register

- Identify, track and manage risks, i.e.:
 - Safety, environmental, weather, labor/contractor resources
 - Design/Engineering progressing to IFC
 - Supply chain issues
 - PV Installation: Civil, mechanical/electrical/civil work, electrical

Appendix 11: Project Controls

- HV Installation: Collector substation, transmission lines, etc.
- Handover requirements/readiness
- Political changes
- Ensure risks are listed with potential schedule and/or cost impacts
- Articulate the frequency that the Risk Matrix will reviewed, updated and shared with Entergy, i.e. included in the monthly Report
- Request Entergy to share lessons learned from previous projects
- Please provide an example of your risk matrix for review

Schedule and Performance Management: “Plan The Work – Work The Plan”

Purpose: Planning the work involves having a project schedule that shows a sophisticated approach to planning the work, including demonstrating an understanding of the resources that will be required (Man Hours, equipment, subcontractors), weather, procurement, labor availability, etc. Communicating the plan to all supervisors, managers, and project leaders is critical in establishing universal and unified performance. Ensuring that the plan is being worked involves tracking progress and updating the schedule and plan when challenges or changes occur; to accomplish this, frequent reporting to all project leadership is critical.

11. Schedule Management Plan

- Articulate the schedule strategy, control requirements, software tool selection, frequency of updates, etc. Refer to the detailed expectations in the Scope of Work document
- Describe how installation velocity will be tracked
- Articulate how often the velocity reporting and schedules will reviewed and updated and how the information will be shared with Entergy, i.e. Weekly for velocity, monthly for P6 schedule updates, etc.
- Refer to the detailed expectations in the Scope of Work document
- Please provide an example of your weekly velocity tracker for review

12. Preliminary Baseline Level I and Level II Project Schedules and WBS

- Baseline schedules – provide the initial baseline schedule for the project
- Refer to the detailed expectations in the Scope of Work document

13. Performance Measurement Baseline

- Describe how performance will be tracked, managed and reported, i.e. in the monthly report
- Describe key commodities that will be tracked via Velocity Installation Curves
- Refer to the detailed expectations in the Scope of Work document
- Articulate the information that will be shared in the Monthly Reporting/Weekly Reporting
- Please provide an example of your Monthly Reporting / Weekly Reporting



Solar BOT Scope Book

Appendix 12

O&M Structure Requirements

REVISION RECORD			
Revision No.	Approval Date	Section / Page Revised	Reason / Description of Change
0	9/14/2023	All	Original Publication
25-1	5/19/2025	All	Editorial Updates
26-1	3/3/2026	All	General Updates
26-2	4/13/206	All	Wind Speed Risk Category for RFP Submittal

Appendix 12: O&M Structure Requirements

Optional O&M Building

Buildings at the Project Site shall be designed in accordance with the requirements of all laws, International Building Code (IBC), ASCE 7 risk category III and applicable permits. Adequate spatial separation shall be provided to other assets to prevent secondary damage per NFPA-80a, assuming no fire department mitigation.

- 4,000 sq ft minimum footprint (3,500 sq ft min warehouse space) – an additional 500 sq ft for each 50 MW_{ac} over 100 MW_{ac}.
- Concrete slab shall be a minimum of 6 inches thick with #4 rebar spaced at 12 inch O.C. each way and sealed.
- 14 foot minimum eave height.
- Roof pitch will be a minimum of 1:12.
- Gutters/downspouts with simple trim shall be installed.
- Min (2) insulated overhead roll-up doors of at least 12 ft x 12 ft.
- Min (3) man doors (one at each roll up door and one inside office area).
- All utilities including phone/fiber, electricity, water, sewer, and gas if applicable.
- Fire extinguisher(s) placed per NFPA-10
- Air conditioned space to include at a minimum:
 - Minimum 8 ft ceilings.
 - Minimum 2 inch x 4 inch x 8 ft studs with 2 inch x 6 inch ceiling joist with no exposed framing.
 - Two offices.
 - One bathroom with sink and toilet.
 - One hot water heater.
 - Common area with room for fridge, counter space, meeting table, and 6 chairs.
 - Receptacles shall be properly placed to code, 2 data drops, A/C and water heater drops (if applicable) and minimum 200 Amp single phase overhead service.
 - 8 ft x 10 ft locked storage room for climate controlled stored items.
 - One direct to outside man door.
 - Non combustibile insulation and finished/painted drywall interior and exterior walls (minimum ½" drywall complete with molding).
- Metal Building Requirements
 - Concrete slab shall have minimum 2 ft x 2 ft x 2 ft pier footings at each metal building column and 1 ft x 1 ft perimeter footing.
 - Roof panels shall be a minimum of 26 ga. PBR Galvalume finish w/Zac screws.
 - Wall panels shall be minimum of 26 ga. PBR ACI 2000 color finish w/standard screws.
 - 3" VR non combustibile metal building insulation in walls and roof.
 - Gutters and downspouts shall be a minimum 26 ga. and ACI 2000 color finish.



Solar BOT Scope Book

Appendix 13

Environmental Guidelines

REVISION RECORD			
Revision No.	Approval Date	Section / Page Revised	Reason / Description of Change
0	9/14/2023	All	Original Publication
25-1	5/19/2025	All	Editorial Updates
26-1	3/3/2026	All	General Updates

Appendix 13: Environmental Guidelines

1 Overview

This document is a guide to environmental requirements and issues related to site work activities associated with the construction of a solar photovoltaic facility. The Contractor who signs a contract with Entergy is stating he or she has read the Contractor Environmental Guidelines and that the Contractor, his employees, and his or her subcontractors shall abide by job specifications and these guidelines.

The local, state, and federal environmental rules and regulations that most commonly apply during construction projects are addressed in this appendix. Any activity not identified in this section should be conducted in accordance with applicable local, state, and federal requirements, and in consultation with Entergy's Environmental Services (**ES**) Team.

Seller is responsible for preparing permit applications, studies/evaluations, and obtaining authorizations necessary for complying with applicable local, county, state, and federal requirements for the construction of the solar project. A Project/Project Site-specific health, safety, and environmental policy and associated procedures (HSE Plan) for the performance of the work outlined in of the Scope Book shall be in alignment with Entergy's Environmental Guidelines contained in this document. Documentation of ongoing compliance activities is required to be maintained during construction of the project and provided to ES as outlined in the Scope Book.

1.1 Oversight

The Buyer's Environmental Specialist in conjunction with the Project Manager and/or ES will have ability to provide recommendations and oversight for environmental issues.

The Buyer's Environmental Specialist in conjunction with the Project Manager will have the authority to stop work if there is a violation of environmental requirements, or there is an observed immediate hazard to health or the environment.

The following sections outline Entergy's environmental guidelines for the rules and regulations applicable to solar construction projects.

2 Phase I, II, and III Site Evaluation

Seller shall cause the Environmental Consultant to conduct Environmental Assessments (**EA**) on behalf of Seller and Buyer in compliance with Good Industry Practices and the then-current requirements and Laws reasonably in advance of the FNTF Date and within 180 days prior to the Closing.

Seller shall provide to Buyer reasonable advance notice of any EA conducted by the Environmental Consultant. Buyer shall have to the right to witness the performance of the EA and to communicate directly and in real time with the Environmental Consultant regarding the inclusion or exclusion of any Recognized Environmental Conditions (**RECs**) within any EA.

The accuracy of any identified REC, or the determination of "no RECs" within an EA will be assessed by the Buyer's Environmental Team prior to finalizing the EA.

The following should be considered when an EA identifies a REC on the property:

- Eliminate risk by avoiding the area(s) with the identified REC(s)
- Assess risk by completing a Phase II of the areas in question to better assess actual contamination.
- Mitigate risk by remediation

Appendix 13: Environmental Guidelines

Each EA should be closely reviewed with the Environmental Team to understand and assess potential risk to the Buyer and to accurately report the conditions at the site. Any decision to complete a Phase II will be on a case-by-case basis.

3 Natural Resource Permitting

3.1 Wetland Delineation and T&E Survey

A wetland delineation is required to identify potential wetland areas within the footprint of the Project and associated construction activities for submittal to the U.S. Army Corps of Engineers (**USACE**) for a determination on potential wetlands impact to be made. Compensatory mitigation will be required by the USACE and State Department of Natural Resources for impacts to wetlands. It is Entergy's position that jurisdictional wetlands are to be avoided to the extent possible without inhibiting a successful project execution.

3.2 Prepare Wetlands Jurisdictional Determination

Seller will prepare a Wetland Delineation report for submittal to the appropriate District of the USACE with a request for a JD utilizing the 1987 Wetland Delineation Manual with supplemental Regional Supplement. The report will contain a description of field activities, figures, Routine Wetland Determination Data Forms, and site photographs. This report is required for the USACE to determine the limits of their jurisdiction for any wetlands or waters of the U.S. identified in the delineation.

As part of the T&E Survey, a habitat assessment will be performed and will focus on and offsite (adjacent properties) to determine if the proposed Project contains habitat for identified species. The habitat assessment will provide a characterization of the quality and quantity of habitat available to support the T&E species, if they exist. Habitats and sightings identified will be documented on a composite drawing. The assessment will be provided to the Entergy ES team for review. Actions that result from any sighting documentations (e.g., Agency notifications/discussions/subsequent communications, monitoring) shall be communicated as outlined in the Scope Book.

The Contractor and/or employees of the Contractor shall not take or possess any Endangered or Threatened Species as identified 50 CFR Part 10 under the authority of the U.S. Department of the Interior Fish and Wildlife Service. "Take" means to pursue, hunt, shoot, wound, kill, trap, capture, harass, harm or collect or attempt to collect these species. As this refers to animals, this is any part, product, egg, offspring, or the dead body or parts. Possession of feathers of these species will be construed as "take", even if found on the ground. Included are "Migratory Birds", whatever their origin, protected by the Migratory Bird Treaty Act, 16 U.S.C. 703711. The Entergy Environmental Specialist must approve any exceptions only after the Contractor has obtained a permit from the U.S. Fish and Wildlife Service for such activities.

The Contractor and/or employees of the Contractor shall not take or possess any species as identified by the State in which the Contractor offers service. Each State may have their own list of Endangered or Threatened Species, as well as their own prohibitions on other species as well. It is likely that nearly all animal species will be protected in some form. Any exceptions must be approved by the Entergy Environmental Specialist and includes a permit from the State in which the activity will require the disturbance of protected species.

4 Cultural Resources

A cultural resource survey may be required as due diligence for a USACE permit, including an Individual and Nationwide permit authorization. If required, a site cultural survey shall be conducted according to the state regulatory survey protocols. If a cultural site is located, it is suggested that the area be avoided. A desktop cultural restraints analysis shall be conducted to identify known cultural sites within the area to be developed during initial phases of the project.

5 Stormwater Pollution Prevention Plan

5.1 Acquire NPDES Construction Storm Water Permit

Any Contractor that performs construction activities on one or more acres, must comply with Federal, state, and local environmental regulations, including, but not limited to, EPA NPDES General Permit for Storm Water Discharges From Construction Activities (40 CFR Part 122). The state issued Construction General Permit, authorizes stormwater discharges from large and small construction activities.

Projects with a state issued Construction General Permit, including construction activity clearing, grading and excavation that result in land disturbance must develop, implement, and maintain a Storm Water Pollution Prevention Plan (**SWPPP**) until stabilization of the project is complete.

Construction sites discharging stormwater must obtain coverage under the general construction permit and submit the following items to the permitting authority at least 2 weeks prior to commencement of construction:

- A Notice of Intent (**NOI**) in accordance with the requirements of the construction permit
- A complete SWPPP in accordance with the requirements of the construction permit
- An initial permit fee (amounts vary by state) must accompany the NOI

The Contractor shall maintain and, if requested, provide the Entergy Environmental Specialist and Contract Manager with the documents listed below (as applicable) if construction activities will be equal to or greater than 5 contiguous acres:

- A SWPPP
- A subcontractor Certification to abide by the Contractor's SWPPP
- The Contractor's Storm Water Permit number and other pertinent information

Contractor must designate Best Management Practices (**BMPs**) to optimize erosion and sediment control during construction. BMPs can be a combination of non-structural controls such as good housekeeping inspections and emergency action planning and structural controls.

The Contractor shall conduct inspections at least once every 7 calendar days.

Inspections must include all areas of the site disturbed by construction activity and areas used for storage of materials that are exposed to precipitation. Inspectors must look for evidence of, or the potential for, pollutants entering the stormwater conveyance system. Contractor shall maintain copies of these inspections onsite.

The Contractor is responsible for proper management of all wastewaters on construction site as directed by applicable regulations. No un-permitted discharges are allowed. The Contractor shall maintain "good housekeeping," i.e., proper storage of materials, proper disposal of trash and construction waste, and clean up and report spills appropriately.

Appendix 13: Environmental Guidelines

5.2 Site Revegetation

Adequate streamside vegetation buffers should be established based on project needs and site-specific conditions identified in the U.S. Army Corps of Engineers Jurisdictional Determination of wetlands and waters of the U.S. Considerations to soil type, slope, vegetation type, root structure, mean high water mark and average annual rain fall should be appropriately reviewed during development of buffers; where feasible, root structures should be left intact and undisturbed in close proximity to water features. If a streamside buffer cannot be feasibly established, adequate BMPs should be utilized for soil stabilization.

Low growth seed mix shall be planted on all ground inside the fence line. Where feasible, non-invasive, native seed mixes should be utilized for stabilization of disturbed soils outside the fence line. Seed mix shall be recommended by the local state extension agency, and consultation with local, regional, or state NGOs, universities, co-ops, and/or ag-business professionals should be taken into account as part of the seed selection process. Areas inside and outside the fence line disturbed during construction or site remediation shall be reseeded with low growth seed mix prior to closure of the construction stormwater permit.

Seller shall consult with the local state extension agency on recommended application timing offering successful seed germination in the project area. Consideration should be given to a late spring seeding when warmer soil temperatures will favor warm-season grasses. Planting after mid-July (i.e., July 15th) is not recommended as hot and dry weather conditions increase during summer months, limiting germination and seedling survival. When a project requires a summer or fall seeding to meet regulatory requirements, consider using a cover crop and wait to plant the final seed mix in a spring seeding. Drilling, broadcast seeding and hydroseeding are planting techniques that can be utilized during spring months.

5.3 Develop a Spill Prevention, Control, and Countermeasures (SPCC) Plan for Construction

A spill prevention, control and countermeasures plan is required to be prepared and implemented prior to construction work if there will be more than 1,320 gallons on oil onsite or as per SPCC regulations. The SPCC plan shall include the applicable components specified under 40 CFR 112.7.

The Contractor must evaluate the site for spill prevention and control prior to beginning work.

Careful planning and consideration of placement of liquid material equipment must take into account the location of nearby water bodies, such as lakes, rivers, streams, and wetlands. In the event of a spill the contractor must immediately take action to contain the spill and remove contaminated soil. Buyer shall be notified of any spills as outlined in the Scope Book.

Liquid material storage containers with a potential to discharge liquids into nearby waters must have some form of containment and or diversionary structures that would prevent a discharge from reaching nearby waters. At a minimum, one of the following discharge prevention systems must be used (40 CFR 112.7(c)):

- Dikes, berms, or retaining walls sufficiently impervious to contain oil or spilled material.
- Curbing
- Culverting, gutters, or other drainage systems to retain spillage on-site
- Weirs, booms, or other barriers
- Spill diversion ponds
- Retention ponds
- Sorbent materials

The Contractor shall immediately report any instances where oil or hazardous substances are spilled, leaking, or improperly stored or released. If an oily sheen is observed in nearby ditches or other bodies of water or if there are signs of a chemical release, the Contractor shall immediately take action to respond to the incident. Buyer shall be notified of any spills or releases as outlined in Section 8 of the Scope Book.

Appendix 13: Environmental Guidelines

Any Contractor who refuels, repairs, replaces, or dismantles petroleum filled, or other hazardous material containers, shall meet the applicable Federal, state, and local regulations. This includes, but is not limited to EPA Spill Prevention, Control and Countermeasures (**SPCC**) (40 CFR Part 112), RCRA, DOT Loading and Unloading Procedures (49 CFR Parts 171, 173, 174, 177, and 179).

5.4 On-site Wastewater Disposal System

Onsite Wastewater Systems and their authorizations required are discussed in further detail in Section 7 of these Contractor Environmental Guidelines.

6 Hazard Communication and Chemical Approval

The Contractor shall comply with hazard communication requirements found in 29 CFR 1910.1200, (OSHA) Hazard Communication Standard for all hazardous chemicals used on site during the course of the job whether supplied by Entergy or the Contractor.

The Contractors shall label in accordance with 29 CFR 1910.1200 all portable containers into which hazardous chemicals are transferred that are not intended for immediate use by the employee who performs the transfer. Labeling shall indicate the hazardous material contained in the container and provide hazard warnings.

6.1 Storage and Use of Chemicals

The Contractor shall employ best management practices (**BMPs**) to help reduce stormwater pollution from the use and storage of chemicals. BMPs must meet the requirements of the appropriate construction storm water general permit at a minimum, in addition to any site specific BMPs included in the Spill Prevention, Control, and Countermeasures (**SPCC**) plan and Storm Water Pollution Prevention Plan (**SWPPP**). The Contractor will be required to review and acknowledge the requirements of the plans prior to beginning work on site. As required, a copy of the SWPPP and SPCC plan and records will be maintained on site in the Contractor's site office.

The Contractor shall ensure all containers of chemical products including but not limited to lubricants, grease, cutting fluids, oils, solvents, degreasers, cleaners, paints, coatings, paint thinners, glues, adhesives, resins, desiccants, or any water-soluble material shall be kept closed at all times except when adding or removing materials.

Container lids, bungs, rings, gaskets, bands, vents and caps shall be adequate and properly secured to prevent the intrusion of rainfall into the container and spillage or evaporation of the container contents.

All containers shall be adequately labeled as to contents and hazards in compliance with the OSHA Hazard Communications Standard and with the name of the Contractor who either owns the container or is responsible for its use.

The Contractor shall maintain and not remove or deface warning labels and markings on any container of DOT hazardous materials.

The Contractor shall store all chemicals and liquid fluid materials in temporary storage facilities.

Temporary storage facilities shall provide spill containment volume for stored material equal to the volume of the largest liquid filled container stored plus 10 percent allowance for rainfall for uncovered containers. Covered containers spill containment volume area must contain the largest container's volume released into the containment area.

Appendix 13: Environmental Guidelines

All chemicals stored in a temporary storage facility shall be elevated by use of pallets or similar devices to prevent contact with any accumulated rainfall or spilled material within the containment area and to facilitate leak detection.

Temporary storage facilities shall be impervious to the materials stored there for a minimum contact time of 72 hours.

Temporary storage facilities shall be maintained free of accumulated rainwater and spills. In the event of spills or leaks, contaminated rainwater and spill material shall be placed into drums after each rainfall event. These drums shall be handled as hazardous waste unless testing determines them to be non-hazardous. Non-hazardous waste shall be disposed in accordance with the requirements of the EPC Contract.

Temporary storage facilities shall provide sufficient separation between stored containers to allow for inspection, spill cleanup, and emergency response. Drums shall not be double stacked.

Incompatible chemicals shall not be stored in the same temporary storage facility unless properly segregated.

Temporary storage facilities shall be covered during non-working days and prior to rain events. Covered facilities may include use of properly secured plastic tarps or constructed roofs with overhangs. Container labels should remain clearly visible.

The Contractor shall employ appropriate signage at temporary storage facilities to indicate any hazards present, precautions or prohibitions (i.e., “no smoking or open flame”) required to ensure the safe storage of the chemicals present and to prevent accidental release.

7 Waste Management

All waste generated by the Contractor or his or her subcontractors while performing task under contract to or authorized by Entergy shall be managed or disposed in accordance with the requirements of the EPC Contract.

The Contractor shall be responsible for ensuring that all wastes which he/she is herein required or authorized to dispose are disposed at a vendor approved by Entergy.

The Contractor is responsible for proper management of waste on site as directed by applicable regulations, and as directed herein.

7.1 Solid Waste Registration ID

A solid waste registration ID is required if more than 220 lbs of Class 1 waste, 220 lbs of hazardous waste, or 2.2 lbs of acutely hazardous waste is generated in a single month and more than once per year. The Contractor shall obtain a solid waste registration ID from the TCEQ, LDEQ, MDEQ, or ADEQ prior to shipping the waste offsite for disposal.

Seller is responsible for completing the required annual waste summaries and paying the associated hazardous waste generation fees.

7.2 Episodic Waste Generation

The generation of more than 220 lbs of hazardous waste, or 2.2 lbs of acutely hazardous waste, in a single month can qualify as Episodic Waste Generation as outlined under 40 CFR §262.232. Unregistered/inactive and registered generators can have either one planned or one unplanned episodic event per calendar year.

Appendix 13: Environmental Guidelines

Episodic waste generators must ship the episodic waste off-site within 60 days of the start date of the episodic event. The 60-day limit for a planned episodic event starts on the first day of any activities affiliated with the event. For an unplanned episodic event, the event begins on the first day the hazardous waste is generated, regardless of whether the generator has completed analysis confirming that the waste is hazardous.

7.3 General Requirements

The Contractor shall be able to properly profile waste to waste vendors including but not limited to samples, waste analysis, SDS, origin, quantity, weight, amount, composition, characteristics, intent and type of use, reason for disposal, and other required data.

The Contractor shall employ best management practices (*BMPs*) to help reduce stormwater pollution from the use and storage of waste.

The Contractor shall store all hazardous waste in temporary accumulation facilities or in a permanent hazardous waste accumulation area.

The Contractor shall manage waste and maintain records of waste accumulation and disposal in accordance with the appropriate state regulations and EPA (40 CFR Part 262) hazardous waste generator accumulation rules.

Temporary hazardous waste accumulation facilities shall provide spill containment volume for stored material equal to the volume of the largest liquid filled container stored plus 10 percent allowance for rainfall for uncovered containers. Covered containers spill containment volume area must contain the largest container's volume released into the containment area.

Temporary hazardous waste accumulation facilities shall be impervious to the materials stored there for a minimum contact time of 72 hours.

Temporary hazardous waste accumulation facilities shall be maintained free of accumulated rainwater and spills. In the event of spills or leaks, contaminated rainwater and spill material shall be placed into drums after each rainfall. These drums shall be handled as hazardous waste until a waste characterization is completed.

Temporary hazardous waste accumulation facilities shall provide sufficient separation between stored containers to allow for inspection, spill cleanup, and emergency response. Container labels shall also be clearly visible and faced into the aisles if they are formed.

Incompatible waste shall not be stored in the same temporary hazardous waste accumulation facility.

Temporary hazardous waste accumulation facilities shall be covered during non-working days and prior to rain events. Covered facilities may include use of properly secured plastic tarps or constructed roofs with overhangs.

Temporary hazardous waste accumulation facilities shall be inspected weekly for the presence of rainwater inside the containment, open or damaged containers, container closure, correct labeling and marking, spills, leaks, container integrity and general housekeeping. The Contractor shall maintain copies of these weekly inspections.

7.4 Oily Absorbent Pads and Cleaning Rags

The Contractor shall dispose of all oily absorbent pads or rags in trash receptacles and ensuring the following conditions are met:

- Pads and rags, once appropriately rung, do not contain any free liquids (liquids drip from waste at a rate of > 1 drop in 5 minutes).

Appendix 13: Environmental Guidelines

- Pads and rags do not contain any hazardous waste such as ignitable or combustible solvents or chlorinated organic compounds such as but not limited to degreasers and cleaning compounds.

Disposal of any absorbent pads and rags that do not meet these conditions shall not be disposed. Pads and rags that contain free liquid must be rung dry prior to disposal or be contained in sufficient adsorbent to bind free liquids prior to disposal.

7.5 Aerosol Cans

All spent aerosol cans that have no propellant or chemical remaining can be disposed of as non-regulated trash or recycled. This means that no liquid is felt or heard when the can is shaken by hand, and no gas or liquid is released when the spray/discharge valve is activated and the container is rotated through all directions, and the valve is not observably or known to be clogged. Non spent aerosol cans may be punctured and drained. The remaining propellant or chemical drippings must be disposed of as hazardous waste.

All aerosol cans that have propellant or chemical remaining shall be considered a "Hazardous Waste" in Louisiana and Mississippi and "Universal Waste" in Texas and Arkansas and disposed accordingly. These aerosol cans must be placed in a drum in the waste storage area. The drum must be labeled with the words "Universal Waste Aerosol Cans" or "Hazardous Waste Aerosol Cans" as applicable. All container markings must be weatherproof and clearly visible. Containers must also be marked with the site's name. Containers must be kept closed except when adding or removing cans. When the container is full, a waste shipping paper or manifest must be completed and shipped with the container.

7.6 Antifreeze/Ethylene Glycol

The Contractor shall collect and place all waste antifreeze or ethylene glycol in a closed head 55-gallon drum appropriately labeled with a Waste Liquid Label as shown in Appendix II or alternately with the identity of the contents, Contractor's name, and date. The Contractor shall keep the drums closed at all times except when adding or removing waste.

7.7 Batteries

Rechargeable batteries must be managed as Universal Waste. Other small, non-rechargeable, single-use batteries may be disposed of as non-hazardous office waste. The Contractor shall collect and place all alkaline, dry cell, button, spent rechargeable and non-leaking sealed small lead acid batteries in 5-gallon plastic pails appropriately labeled with the words "Used Batteries" and the date or alternately the words or label "Universal Waste". The container must be marked with the date the first battery is placed in the container. The Contractor shall cover the terminals of all used batteries with electrical or duct tape to prevent electrical discharge or arcing prior to placing in the container. For larger batteries, terminals can be taped instead of putting the batteries in plastic bags. When the container is full but NO LATER THAN ONE YEAR from the date on the container, close up the container, and ship to the appropriate recycler.

Larger lead acid batteries must be placed in containers and labeled "Lead-Acid Batteries for Recycling" and stored in a designated accumulation area at the site. Batteries should be stored on a level surface in an upright position and secured as appropriate to prevent tipping. Batteries designated for transport must be appropriately secured and prevented from electrical short-circuit.

7.8 Truck Wash Out and Excess Concrete Waste Management

The Contractor shall perform washout of concrete trucks offsite or in designated areas. The Contractor shall wash out concrete truck waste and excess concrete into a temporary pit where the concrete can be set, be broken up, and then disposed properly. Wash waters generated during this activity should be properly disposed of according to the applicable State construction storm water general permit. BMP's shall be

Appendix 13: Environmental Guidelines

established to prevent the concrete wash out water from contributing to groundwater contamination or entering the waters of the state.

7.9 Empty Containers

The Contractor shall ensure that all discarded containers (i.e., drums, buckets, cans, pails) meet the EPA's definition of empty (the entire residue has been removed that can be removed using normal means and no more than 1" of residue remains in the bottom of the container) prior to recycle or disposal. The Contractor may crush, flatten, or otherwise render useless metallic containers > 5 gallon capacity and dispose in a scrap metal receptacle.

7.10 Filters

The Contractor shall puncture and hot drain all used fuel, lubricating oil, and hydraulic oil filters into a labeled filter collection drum containing adsorbent media.

Once the filters are drained, the Contractor shall manage them as scrap metal. The absorbent media shall be disposed.

Alternatively, the entire filter may be placed into a container provided by a used oil recycle vendor for management at a recycle facility.

The Contractor shall place used air filters in receptacles.

7.11 Lighting Waste

All spent lamps which have bright green end caps, green paint on the end, a green "dimple" on the end or green writing on the lamp can be disposed of as non-regulated trash. All others must be recycled. For Mississippi, if the facility generates less than 220 pounds/month of hazardous waste including the lamps, the facility would be conditionally exempt and may dispose of the lamps as normal solid waste.

7.11.1 Arkansas, Louisiana, Mississippi (if small or large generator) and Texas

The Contractor shall place all used unbroken lighting waste (fluorescent bulbs, high intensity discharge lamps, and incandescent lamps) in containers designed to prevent breakage. The containers shall be labeled or marked with the words or label, "Universal Waste", date, and identity of the contents (i.e., HID Lamps). Containers must be marked with the site's name and must be kept closed except when adding or removing lamps. When the container is full, but no later than 1 year from the date on the container, send the container to the waste vendor. All container markings must be weatherproof and clearly visible. The Contractor shall store and manage lighting waste to prevent breakage.

The Contractor shall place all broken lighting waste (fluorescent bulbs, high intensity discharge lamps, and incandescent lamps) in secure containers such as a 5 5-gallon bucket.

7.11.2 Louisiana, Mississippi (if small or large generator) and Texas

The containers shall be labeled or marked with the words or label, "Universal Waste Lamps for Recycling", with "Broken" added to the label in an indelible marker and with the date the first broken bulb is placed in the container and the site's name. Containers must be kept closed except when adding or removing lamps. When the container is full, but no later than 1 year from the date on the container, send the container to the waste vendor.

7.11.3 Arkansas

The containers shall be labeled or marked with the words or label, "Hazardous Waste – Broken Lamps". The container must be labeled using an indelible marker and with the date the first broken bulb is placed in

Solar BOT Scope Book: Appendix 13 Environmental Guidelines

Appendix 13: Environmental Guidelines

the container and the site's name. Containers must be kept closed except when adding or removing lamps. When the container is full, send the container to the waste vendor for proper disposal.

7.12 Mercury Wastes

Any mercury containing wastes such as, switches, thermometers, etc., shall be double bagged by the contractor in sealed plastic zip-lock type bags, and appropriately labeled with the words or label, "Hazardous Waste", the date, and description of contents and disposed in accordance with the requirements of the EPC Contract.

7.13 Waste Paint Management

The Contractor shall ensure that wastes generated during painting operations are managed in a manner that is in compliance with applicable environmental regulations. (More info available if needed)

7.14 Sanitary/Septic, Personnel Waste Management

The Contractor shall arrange for regular sanitary/septic waste collection and off-site disposal by reputable, licensed sanitary/septic waste haulers.

The Contractor shall not dispose of wastewater from personnel washing stations, laundry or food service facilities into site stormwater drains, sanitary sewers, watercourses, conveyances, and surface impoundments.

Personnel washing station, laundry and/or food service wastewaters shall be collected, managed, and be disposed off-site by reputable, licensed sanitary/septic waste haulers.

7.15 Scrap Metal

The Contractor shall collect and place all scrap metals, metal turnings, and metal shavings in labeled scrap metal receptacles. The Contractor will ensure that no electronic or generally licensed radioactive devices are allowed to be placed into the scrap metal receptacles.

7.16 Solar Panel Waste

Damaged solar panels are NOT considered electronic waste and are NOT considered universal waste.

Damaged solar panels are to be handled, stored, and disposed/recycled as hazardous solid waste until they are proven to be non-hazardous according by either:

- The toxicity characteristic leaching procedure (**TCLP**), a test required under RCRA, or
- Documentation provided by the panel manufacturer that demonstrates the solar panel waste is non-hazardous.

7.17 Storage Requirements

Damaged solar panels must be stored in a designated waste storage area and in covered containers or be off the ground and covered so as not to be exposed to rainwater.

Each container used for on-site hazardous waste accumulation must be labeled or marked in accordance with the appropriate label (non-hazardous, hazardous, solid waste) compliant with the waste characterization. The label shall include an indication of the hazards of the contents, and the date on which accumulation began (sections 262.16(b)(6) and 262.17(a)(5)). Containers must be marked with the site's name. All container markings must be weatherproof and clearly visible.

Panels can also be labeled as "Hazardous Waste Pending Analysis" while analytical testing is being conducted, the hazard that is being analyzed, along with the date upon which accumulation began. If the

Solar BOT Scope Book: Appendix 13 Environmental Guidelines

Appendix 13: Environmental Guidelines

waste is determined to be non-hazardous, the generator can remove the hazardous waste label at that point.

7.17.1 Disposal Requirements

Damaged solar panels shall be handled, stored, and disposed/recycled in accordance with state and federal transportation and waste regulations at a regulated waste disposal authorized to receive hazardous waste, industrial solid waste, or at a recycling facility.

Damaged solar panels shall be manifested for transportation to the disposal or recycling facility.

7.17.2 Recordkeeping Requirements

Documentation of the waste determination for the panels must be maintained with the waste disposal manifest or recycling manifests for the duration of the project and provided to the Buyer as outlined in the Scope Book.

The signed manifest from the treatment, storage and disposal facility (*TSDF*), recycling facility, or the regulated waste disposal facility shall be maintained for the duration of the project.

7.18 Spill Cleanup/Petroleum Contaminated Soils

The Contractor shall at all times perform his work in a manner to eliminate spills and take necessary precautions to prevent their occurrence especially around fuel and oil storage tanks, reservoirs, and containers.

The Contractor shall promptly notify the Buyer as outlined in Section 8 of the Scope Book of all spills. The Contractor is responsible to cleanup and manage the spill material.

The Contractor shall immediately clean up and containerize petroleum contaminated soils resulting from spills in and around storage tanks, reservoirs, and containers of virgin or used fuels, oils, hydraulic fluids or used oil. The containers shall be labeled with a Waste Solid Label or with wording or labels identifying the contents, the Contractor's name and the date. Containers shall be kept closed at all times except when adding or removing waste.

7.19 Trash

The Contractor shall place all nonhazardous solid waste (trash) in labeled containers. The Contractor shall ensure that his employees do not dispose of any hazardous, universal, industrial solid, Class I, or Class II waste in trash containers. (Examples of prohibited waste include but are not limited to batteries, solvents, aerosol cans, used blasting media, contaminated rags, etc.).

7.20 Used Oil

The Contractor must label all tanks, drums, and containers that contain used oil with a Waste Liquid Label or the words "Used Oil", including the type of oil. Maintain good records of used oil shipments from the facility.

The Contractor shall keep all tanks and containers of used oil securely closed with bungs. Vents should also be in place except when adding or removing oil. Oil must never be put in open top drums.

The Contractor shall not mix used oil with other substances, such as, but not limited to antifreeze, brake fluid, gasoline, paint thinner, solvents, because doing so may render the entire mixture as a hazardous waste.

The Contractor shall immediately report any instances where oil has spilled, leaked or been improperly disposed, or improperly stored. If an oily sheen is observed in nearby ditches or other bodies of water, the

Solar BOT Scope Book: Appendix 13 Environmental Guidelines

Appendix 13: Environmental Guidelines

Contractor shall immediately take action to eliminate the source of the oil and remove and manage the spilled material. The Contractor shall promptly notify the Buyer as outlined in Section 8 of the Scope Book of all spills

Only use permitted used oil processors/refiners for recycling and only use permitted transporters for the transport of used oil in quantities greater than 55 gallons. For quantities greater than 55 gallons, used oil shipments must be accompanied by the DOT used oil shipping document and the transporter must keep a record of the shipment.

The Contractor shall comply with the applicable oil spill prevention, control and countermeasure regulations.

8 Other Environmental Permitting

8.1 Aboveground Storage Tanks

The Contractor shall immediately notify the Entergy Environmental Specialist or Contract Manager should there be accidental contact with underground or aboveground storage tanks, piping and/or associated equipment that results in, or is anticipated to result in, a release of contents, or if they notice any leaks or spills.

Any Contractor who removes, repairs, replaces, or refuels/refills underground or aboveground storage tanks and/or associated equipment must meet all Federal, state, and local environmental regulations governing these tanks and equipment. This includes, but is not limited to, EPA Underground Storage Tanks (40 CFR Parts 280 and 281), EPA SPCC regulation (40 CFR 112), DOT Transportation of Hazardous Materials (49 CFR), and RCRA hazardous waste regulations (40 CFR 240281), and State specific requirements.

8.2 On-Site Sewage Facilities (Septic Systems)

8.2.1 Texas Requirements

An on-site sewage facility (**OSSF**) permit and an approved plan are required to construct, alter, repair, extend, or operate an OSSF per 30 TAC Chapter 285, Subchapters A and D. Seller must construct and operate the wastewater system in accordance with all permit conditions and requirements per 30 TAC Chapter 285, Subchapters A and D.

Seller shall contact the TCEQ prior to construction of the OSSF to determine applicability of a TPDES permit. Seller shall comply with all reporting, testing, recordkeeping and maintenance requirements associated with the TPDES permit, if required.

8.2.2 Arkansas Requirements

An Onsite Wastewater System construction permit and operating permit are required from the Arkansas Division of Health or its authorized agent, prior to construction or operation of an on-site wastewater system.

An NPDES Individual No-Discharge Permit from the ADEQ is required prior to construction of an on-site wastewater system with a spray-field application of effluent. Seller shall contact ADEQ prior to construction to determine applicability of the NPDES permit. Seller shall comply with all reporting, testing, recordkeeping and maintenance requirements in the NPDES permit.

Appendix 13: Environmental Guidelines

8.2.3 Mississippi Requirements

A notice of intent (**NOI**) and Permit/Recommendation for water service connection must be filed with the Mississippi State Department of Health (**MSDH**) for approval of an on-site sewage treatment and disposal system per MSDH, Part 18, Subpart 77.

8.2.4 Louisiana Requirements

Approval of the on-site sewage treatment system must be granted by the Louisiana Department of Health, Office of Public Health and the Louisiana DEQ. LDEQ authorizes wastewater discharges for General Sanitary Permits under the Louisiana Water Discharge Permit System in LAC 33: Part IX Chapters 3 and 7.

9 Project Environmental Considerations

For projects located in Texas, Buyer is required to submit a Certificate of Convenience and Necessity (**CCM**) application to the Public Utility Commission (PUC) for a new solar generating facility. In Arkansas, Buyer is required to submit a Certificate of Environmental Compatibility and Public Need to the Arkansas Public Service Commission for a new solar generating facility

- Texas (see Rule 16 Texas Administrative Code [TAC] § 25.101(b)2).
- Arkansas: See Ark. Code Ann. § 23-18-501, et. Seq. (the “Utility Facility and Economic Production Act”)

The Buyer must be prepared to address its environmental considerations made while designing the proposed project. In Arkansas, Buyer shall prepare an Environmental Impact Statement to address the Project purpose and necessity, the existing environment, evaluation of alternatives, environmental impacts, unavoidable effects, irreversible/irretrievable commitments of resources, and recommended mitigation measures.

In Texas, an Environmental Assessment (**EA**) shall be prepared to address the CCN considerations provided below from the Public Utility Regulatory Act:

Sec. 37.056. GRANT OR DENIAL OF CERTIFICATE.

(c) *The commission shall grant each certificate on a nondiscriminatory basis after considering:*

(4) *other factors, such as:*

- (A) *community values;*
- (B) *recreational and park areas;*
- (C) *historical and aesthetic values;*
- (D) *environmental integrity;*

The content and format of the EA should be guided by the Texas Parks and Wildlife Department Suggested Guidelines for Preparation of Environmental Assessment Documents.

10 Site Conditions

Contractor shall have the sole responsibility of satisfying itself by personal inspection or otherwise concerning the nature and location of Work and the general and local conditions.

Solar BOT Scope Book: Appendix 13 Environmental Guidelines

Appendix 13: Environmental Guidelines

If in the performance of the work at the project the Contractor encounters any Hazardous Substance, pollution or contamination, Contractor will notify the Entergy Environmental Specialist or Contract Manager immediately, and before such conditions are disturbed. Handling or removal of any hazardous substance, pollution or contamination will be in accordance with Contractor's agreement or contractual provisions.